

DIODE DATA BOOK

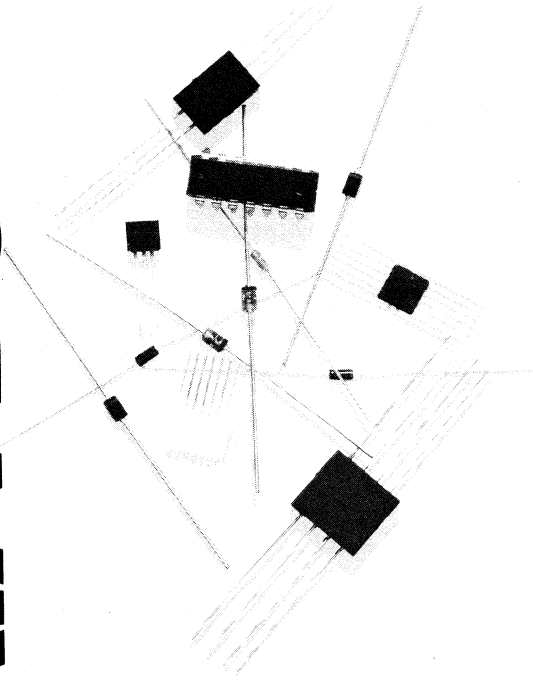

464 Ellis Street, Mountain View, California 94042

©1978 Fairchild Camera and Instrument Corporation/464 Ellis Street, Mountain View, California 94042/(415) 962-5011/TWX 910-379-6435

TABLE OF CONTENTS

NUMERICAL INDEX OF DEVICES	vi
CHAPTER 1	
Selection Guides	1-3
Cross Reference	1-25
CHAPTER 2	
Reliability	2-3
Designed-In Reliability	2-3
Reliability Control	2-4
Reliability Data	2-6
FDH4	2-7
FD5 and FDH5	2-8
FDH6	2-9
FDH9 and FDH11	2-10
1/2 W Zener	2-11
In-Use Reliability	2-12
Air-Isolated Monolithic Diode Array Family	2-13
CHAPTER 3	
PRODUCT INFORMATION	
Data Sheets	3-3
CHAPTER 4	
FAMILY CURVES	4-3
CHAPTER 5	
DIODE GLOSSARY OF SYMBOLS AND TERMS	5-3
CHAPTER 6	
FAIRCHILD FIELD SALES OFFICES, SALES REPRESENTATIVES AND DISTRIBUTOR LOCATIONS	6-3

NUMERIC PRODUCT LISTING

Device	Type	Page No.	Device	Type	Page No.
BAV17	Small Signal Diode	3-3	BZX85C4V3	Zener Diode	3-20
BAV18	"	3-3	BZX85C4V7	"	3-20
BAV19	"	3-3	BZX85C5V1	"	3-20
BAV20	"	3-3	BZX85C5V6	"	3-20
BAV21	"	3-3	BZX85C6V2	"	3-20
BAW75	"	3-4	BZX85C6V8	"	3-20
BAW76	"	3-4	BZX85C7V5	"	3-20
BAX13	"	3-5	BZX85C8V2	"	3-20
BAX16	"	3-6	BZX85C9V1	"	3-20
BAY71	"	3-7	BZX85C10	"	3-20
BAY72	"	3-8	BZX85C11	"	3-20
BAY73	"	3-9	BZX85C12	"	3-20
BAY74	"	3-10	BZX85C13	"	3-20
BAY80	"	3-8	BZX85C15	"	3-20
BAY82	"	3-11	BZX85C16	"	3-20
BA128	"	3-12	BZX85C18	"	3-20
BA129	"	3-9	BZX85C20	"	3-20
BA130	"	3-12	BZX85C22	"	3-20
BA180	"	3-13	BZX85C24	"	3-20
BA181	"	3-13	BZX85C27	"	3-20
BA216	"	3-14	BZX85C30	"	3-20
BA217	"	3-14	BZX85C33	"	3-20
BA218	"	3-14	BZY88C3V3	"	3-21
BA219	"	3-14	BZY88C3V6	"	3-21
BA243	"	3-15	BZY88C3V9	"	3-21
BA244	"	3-15	BZY88C4V3	"	3-21
BB121A	Varactor Diode	3-16	BZY88C4V7	"	3-21
BB121B	"	3-16	BZY88C5V1	"	3-21
BB122	"	3-16	BZY88C5V6	"	3-21
BB139	"	3-17	BZY88C6V2	"	3-21
BB204B	Dual Varactor Diode	3-18	BZY88C6V8	"	3-21
BB204G	"	3-18	BZY88C7V5	"	3-21
BZX55C3V3	Zener Diode	3-19	BZY88C8V2	"	3-21
BZX55C3V6	"	3-19	BZY88C9V1	"	3-21
BZX55C3V9	"	3-19	BZY88C10	"	3-21
BZX55C4V3	"	3-19	BZY88C11	"	3-21
BZX55C4V7	"	3-19	BZY88C12	"	3-21
BZX55C5V1	"	3-19	BZY88C13	"	3-21
BZX55C5V6	"	3-19	BZY88C15	"	3-21
BZX55C6V2	"	3-19	BZY88C16	"	3-21
BZX55C6V8	"	3-19	BZY88C18	"	3-21
BZX55C7V5	"	3-19	BZY88C20	"	3-21
BZX55C8V2	"	3-19	BZY88C22	"	3-21
BZX55C9V1	"	3-19	BZY88C24	"	3-21
BZX55C10	"	3-19	BZY88C27	"	3-21
BZX55C11	"	3-19	BZY88C30	"	3-21
BZX55C12	"	3-19	BZY88C33	"	3-21
BZX55C13	"	3-19	FA2310E	Diode Assembly	3-24
BZX55C15	"	3-19	FA2310U	"	3-24
BZX55C16	"	3-19	FA2311E	"	3-24
BZX55C18	"	3-19	FA2311U	"	3-24
BZX55C20	"	3-19	FA2312E	"	3-24
BZX55C22	"	3-19	FA2312U	"	3-24
BZX55C24	"	3-19	FA2313E	"	3-24
BZX55C27	"	3-19	FA2313U	"	3-24
BZX55C30	"	3-19	FA2320E	"	3-24
BZX55C33	"	3-19	FA2320U	"	3-24
BZX85C3V3	"	3-20	FA2321E	"	3-24
BZX85C3V6	"	3-20	FA2321U	"	3-24
BZX85C3V9	"	3-20	FA2322E	"	3-24

NUMERIC PRODUCT LISTING (Cont'd)

Device	Type	Page No.	Device	Type	Page No.
FA2322U	Diode Assembly	3-24	FA4325U	Diode Assembly	3-24
FA2323E	"	3-24	FA4330E	"	3-24
FA2323U	"	3-24	FA4330U	"	3-24
FA2324E	"	3-24	FA4331E	"	3-24
FA2324U	"	3-24	FA4331U	"	3-24
FA2325E	"	3-24	FA4332E	"	3-24
FA2325U	"	3-24	FA4332U	"	3-24
FA2330E	"	3-24	FA4333E	"	3-24
FA2330U	"	3-24	FA4333U	"	3-24
FA2331E	"	3-24	FA4334E	"	3-24
FA2331U	"	3-24	FA4334U	"	3-24
FA2332E	"	3-24	FA4335E	"	3-24
FA2332U	"	3-24	FA4335U	"	3-24
FA2333E	"	3-24	FA4360E	"	3-24
FA2333U	"	3-24	FA4360U	"	3-24
FA2334E	"	3-24	FA4361E	"	3-24
FA2334U	"	3-24	FA4361U	"	3-24
FA2335E	"	3-24	FDH300	Single Junction Diode	3-26
FA2335U	"	3-24	FDH333	"	3-26
FA2360E	"	3-24	FDH400	"	3-27
FA2360U	"	3-24	FDH444	Small Signal Diode	3-27
FA2361E	"	3-24	FDH600	"	3-28
FA2361U	"	3-24	FDH666	"	3-28
FA3310	"	3-24	FDH900	"	3-29
FA3311	"	3-24	FDH999	"	3-29
FA3312	"	3-24	FDH1000	"	3-30
FA3313	"	3-24	FD700	"	3-31
FA3320	"	3-24	FD777	"	3-31
FA3321	"	3-24	FH1100	Hot Carrier Diode	3-32
FA3322	"	3-24	FJT1100	Small Signal Diode	3-33
FA3323	"	3-24	FJT1101	"	3-33
FA3324	"	3-24	FSA1410M	Diode Arrays	3-34
FA3325	"	3-24	FSA1411M	"	3-34
FA3330	"	3-24	FSA2002M	"	3-34
FA3331	"	3-24	FSA2003M	"	3-34
FA3332	"	3-24	FSA2500M	"	3-36
FA3333	"	3-24	FSA2501M	"	3-36
FA3334	"	3-24	FSA2501P	"	3-36
FA3335	"	3-24	FSA2502M	"	3-36
FA3360	"	3-24	FSA2503M	"	3-39
FA3361	"	3-24	FSA2503P	"	3-39
FA4310E	"	3-24	FSA2504M	"	3-39
FA4310U	"	3-24	FSA2509M	"	3-41
FA4311E	"	3-24	FSA2509P	"	3-41
FA4311U	"	3-24	FSA2510M	"	3-41
FA4312E	"	3-24	FSA2510P	"	3-41
FA4312U	"	3-24	FSA2563M	"	3-43
FA4313E	"	3-24	FSA2563P	"	3-43
FA4313U	"	3-24	FSA2564M	"	3-43
FA4320E	"	3-24	FSA2564P	"	3-43
FA4320U	"	3-24	FSA2565M	"	3-43
FA4321E	"	3-24	FSA2565P	"	3-43
FA4321U	"	3-24	FSA2566M	"	3-43
FA4322E	"	3-24	FSA2566P	"	3-43
FA4322U	"	3-24	FSA2619M	"	3-46
FA4323E	"	3-24	FSA2619P	"	3-46
FA4323U	"	3-24	FSA2620M	"	3-46
FA4324E	"	3-24	FSA2620P	"	3-46
FA4324U	"	3-24	FSA2621M	"	3-46
FA4325E	"	3-24	FSA2702M	"	3-49

NUMERIC PRODUCT LISTING (Cont'd)

Device	Type	Page No.	Device	Type	Page No.
FSA2703M	Diode Arrays	3-49	1N659	Small Signal Diode	3-60
FSA2704M	"	3-49	1N660	"	3-60
FSA2705M	"	3-49	1N661	"	3-60
FSA2719M	"	3-46	1N746	Zener Diode	3-61
FSA2719P	"	3-46	1N747	"	3-61
FSA2720M	"	3-46	1N748	"	3-61
FSA2720P	"	3-46	1N749	"	3-61
FSA2721M	"	3-46	1N750	"	3-61
MV104	Dual Varactor Diode	3-18	1N751	"	3-61
RF400	Voltage Variable Capacitor Diode	3-51	1N752	"	3-61
RF401	Voltage Variable Capacitor Diode	3-51	1N753	"	3-61
RF500	Dual Varactor Diode	3-52	1N754	"	3-61
ZPD3,3	Zener Diode	3-53	1N756	"	3-61
ZPD3,6	"	3-53	1N757	"	3-61
ZPD3,9	"	3-53	1N758	"	3-61
ZPD4,3	"	3-53	1N759	"	3-61
ZPD4,7	"	3-53	1N914	Small Signal Diode	3-62
ZPD5,1	"	3-53	1N914A	"	3-62
ZPD5,6	"	3-53	1N914B	"	3-62
ZPD6,2	"	3-53	1N916	"	3-62
ZPD6,8	"	3-53	1N916A	"	3-62
ZPD7,5	"	3-53	1N916B	"	3-62
ZPD8,2	"	3-53	1N957	Zener Diode	3-63
ZPD9,1	"	3-53	1N958	"	3-63
ZPD10	"	3-53	1N959	"	3-63
ZPD11	"	3-53	1N960	"	3-63
ZPD12	"	3-53	1N961	"	3-63
ZPD13	"	3-53	1N962	"	3-63
ZPD15	"	3-53	1N963	"	3-63
ZPD16	"	3-53	1N964	"	3-63
ZPD18	"	3-53	1N965	"	3-63
ZPD20	"	3-53	1N966	"	3-63
ZPD22	"	3-53	1N967	"	3-63
ZPD24	"	3-53	1N968	"	3-63
ZPD27	"	3-53	1N969	"	3-63
ZPD30	"	3-53	1N970	"	3-63
ZPD33	"	3-53	1N971	"	3-63
1N456	Small Signal Diode	3-55	1N972	"	3-63
1N456A	"	3-55	1N973	"	3-63
1N457	"	3-55	1N3064	Small Signal Diode	3-64
1N457A	"	3-55	1N3070	"	3-65
1N458	"	3-55	1N3595	"	3-66
1N458A	"	3-55	1N3600	"	3-67
1N459	"	3-55	1N4001	Rectifier	3-68
1N459A	"	3-55	1N4002	"	3-68
1N461A	"	3-56	1N4003	"	3-68
1N462A	"	3-56	1N4004	"	3-68
1N463A	"	3-56	1N4005	"	3-68
1N464A	"	3-56	1N4006	"	3-68
1N482B	"	3-57	1N4007	"	3-68
1N483B	"	3-57	1N4009	Small Signal Diode	3-69
1N484B	"	3-57	1N4099	Zener Diode	3-70
1N485B	"	3-57	1N4100	"	3-70
1N486B	"	3-57	1N4101	"	3-70
1N625	"	3-58	1N4102	"	3-70
1N626	"	3-58	1N4103	"	3-70
1N627	"	3-58	1N4104	"	3-70
1N628	"	3-58	1N4105	"	3-70
1N629	"	3-58	1N4106	"	3-70
1N658	"	3-59	1N4107	"	3-70

NUMERIC PRODUCT LISTING (Cont'd)

Device	Type	Page No.	Device	Type	Page No.
1N4108	"	3-70	1N4748	Zener Diode	3-75
1N4109	"	3-70	1N4749	"	3-75
1N4110	"	3-70	1N4750	"	3-75
1N4111	"	3-70	1N4751	"	3-75
1N4112	"	3-70	1N4752	"	3-75
1N4113	"	3-70	1N4933	Rectifier	3-77
1N4114	"	3-70	1N4934	"	3-77
1N4115	"	3-70	1N4935	"	3-77
1N4116	"	3-70	1N4936	"	3-77
1N4117	"	3-70	1N4937	"	3-77
1N4118	"	3-70	1N4938	"	3-65
1N4119	"	3-70	1N5226	Zener Diode	3-78
1N4120	"	3-70	1N5227	"	3-78
1N4121	"	3-70	1N5228	"	3-78
1N4148	Small Signal Diode	3-62	1N5229	"	3-78
1N4149	"	3-62	1N5230	"	3-78
1N4150	"	3-67	1N5231	"	3-78
1N4151	"	3-72	1N5232	"	3-78
1N4152	"	3-72	1N5233	"	3-78
1N4153	"	3-72	1N5234	"	3-78
1N4154	"	3-72	1N5235	"	3-78
1N4244	"	3-11	1N5236	"	3-78
1N4305	"	3-64	1N5237	"	3-78
1N4306	Diode Assembly	3-73	1N5238	"	3-78
1N4307	"	3-73	1N5239	"	3-78
1N4376	Small Signal Diode	3-11	1N5240	"	3-78
1N4446	"	3-62	1N5241	"	3-78
1N4447	"	3-62	1N5242	"	3-78
1N4448	"	3-62	1N5243	"	3-78
1N4449	"	3-62	1N5244	"	3-78
1N4450	"	3-67	1N5245	"	3-78
1N4454	"	3-64	1N5246	"	3-78
1N4620	Zener Diode	3-70	1N5247	"	3-78
1N4621	"	3-70	1N5248	"	3-78
1N4622	"	3-70	1N5249	"	3-78
1N4623	"	3-70	1N5250	"	3-78
1N4624	"	3-70	1N5251	"	3-78
1N4625	"	3-70	1N5252	"	3-78
1N4626	"	3-70	1N5253	"	3-78
1N4627	"	3-70	1N5254	"	3-78
1N4728	"	3-75	1N5255	"	3-78
1N4729	"	3-75	1N5256	"	3-78
1N4730	"	3-75	1N5257	"	3-78
1N4731	"	3-75	1N5282	Small Signal Diode	3-80
1N4732	"	3-75	1N5390	Hot Carrier Diode	3-32
1N4733	"	3-75	1N5768	Diode Array	3-81
1N4734	"	3-75	1N5770	"	3-81
1N4735	"	3-75	1N5772	"	3-81
1N4736	"	3-75	1N5774	"	3-81
1N4737	"	3-75	1N6099	"	3-66
1N4738	"	3-75	1N6100	"	3-83
1N4739	"	3-75	1N6101	"	3-83
1N4740	"	3-75	1S44	Small Signal Diode	3-85
1N4741	"	3-75	1S920	"	3-86
1N4742	"	3-75	1S921	"	3-86
1N4743	"	3-75	1S923	"	3-86
1N4744	"	3-75			
1N4745	"	3-75			
1N4746	"	3-75			
1N4747	"	3-75			

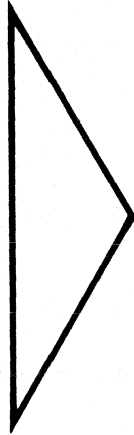
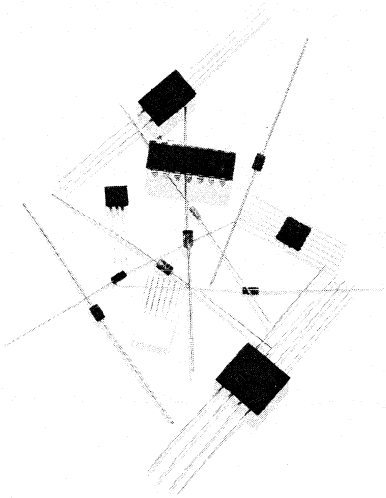

DEVICE SELECTION GUIDES

1

RELIABILITY

2

PRODUCT INFORMATION

3

FAMILY CURVES

4

GLOSSARY OF SYMBOLS AND TERMS

5

FAIRCHILD FIELD SALES OFFICES,
SALES REPRESENTATIVES AND
DISTRIBUTOR LOCATIONS

6

FAIRCHILD DIODES

DIODES

COMPUTER DIODES (BY ASCENDING t_{rr}) GLASS PACKAGE

DEVICE NO.	t_{rr} ns Max	BV V Min	I_R nA Max	@	V_R V	V_F V Max	@	I_F mA	C pF Max	Package No.	Page No.
FD700	0.70	30	50		20	1.1		50	1.0	DO-7	3-31
1N4376	0.75	20	100		10	1.1		50	1.0	DO-7	3-11
1N4244	0.75	20	100		10	1.0		20	0.8	DO-7	3-11
BAY82	0.75	15	100		12	1.0		20	1.3	DO-7	3-11
FD777	0.75	15	100		8.0	1.0		20	1.3	DO-7	3-31
1N5282	2.0	80	100		55	1.3		500	2.5	DO-35	3-80
1N4153	2.0	75	50		50	0.88		20	4.0	DO-35	3-72
1N4151	2.0	75	50		50	1.0		50	4.0	DO-35	3-72
1N4305	2.0	75	100		50	0.85		10	2.0	DO-35	3-64
BAY71	2.0	50	100		35	1.0		20	2.0	DO-35	3-7
1N4152	2.0	40	50		30	0.88		20	4.0	DO-35	3-72
1N4154	2.0	35	100		25	1.0		30	4.0	DO-35	3-72
1N914	4.0	100	25		20	1.0		10	4.0	DO-35	3-62
1N914A	4.0	100	25		20	1.0		20	4.0	DO-35	3-62
1N914B	4.0	100	25		20	1.0		100	4.0	DO-35	3-62
1N916	4.0	100	25		20	1.0		10	2.0	DO-35	3-62
1N916A	4.0	100	25		20	1.0		20	2.0	DO-35	3-62
1N916B	4.0	100	25		20	1.0		30	2.0	DO-35	3-62
1N4148	4.0	100	25		20	1.0		10	4.0	DO-35	3-62
1N4149	4.0	100	25		20	1.0		10	2.0	DO-35	3-62
1N4446	4.0	100	25		20	1.0		20	4.0	DO-35	3-62
1N4447	4.0	100	25		20	1.0		20	4.0	DO-35	3-62
1N4448	4.0	100	25		20	1.0		100	2.0	DO-35	3-62
1N4449	4.0	100	25		20	1.0		30	2.0	DO-35	3-62
1N3600	4.0	75	100		50	1.0		200	2.5	DO-35	3-67
FDH600	4.0	75	100		50	1.0		200	2.5	DO-35	3-28
1N3064	4.0	75	100		50	1.0		10	2.0	DO-35	3-64
1N4150	4.0	75	100		50	1.0		200	2.5	DO-35	3-67
1N4454	4.0	75	100		50	1.0		10	2.0	DO-35	3-64
BAX13	4.0	50	200		50	1.0		20	3.0	DO-35	3-5
BAY74	4.0	50	100		35	1.1		300	3.0	DO-35	3-10
FDH900	4.0	45	500		40	1.1		100	3.0	DO-35	3-29

NOTE—Page number referenced for JAN, JANTX & JANTXV Devices is for standard device, use for electrical characteristics.

1

FAIRCHILD DIODES

DIODES

COMPUTER DIODES (BY ASCENDING t_{rr})
GLASS PACKAGE

DEVICE NO.	t_{rr} ns Max	BV V Min	I_R nA Max	@	V_R V	V_F V Max	@	I_F mA	C pF Max	Package No.	Page No.
FDH666	4.0	40	100		25	1.0		100	3.5	DO-35	3-28
1N4450	4.0	40	50		30	1.0		200	4.0	DO-35	3-67
1N4009	4.0	35	100		25	1.0		30	4.0	DO-35	3-69
1N625	4.0	30	1000		20	1.5		4.0	—	DO-35	3-58
FDH999	5.0	35	1000		25	1.0		10	5.0	DO-35	3-29
FDH1000	100	75	50		20	1.0		500	5.0	DO-35	3-30

LOW LEAKAGE DIODES (BY DESCENDING BV)
GLASS PACKAGE

DEVICE NO.	BV V Min	I_R nA Max	@	V_R V	V_F V Max	@	I_F mA	C pF Max	Package No.	Page No.
1N486B	250	50		225	1.0		100	—	DO-35	3-57
1N485B	200	25		180	1.0		100	—	DO-35	3-57
1N459	200	25		175	1.0		3.0	—	DO-35	3-55
1N459A	200	25		175	1.0		100	—	DO-35	3-55
FDH300	150	1.0		125	1.0		200	6.0	DO-35	3-26
1N3595	150	1.0		125	1.0		200	8.0	DO-35	3-66
1N6099	150	1.0		125	1.0		200	8.0	DO-35	3-66
FDH333	150	3.0		125	1.05		200	6.0	DO-35	3-26
1N458A	150	5.0		125	1.0		100	—	DO-35	3-55
1N484B	150	25		130	1.0		100	—	DO-35	3-57
1N458	150	25		125	1.0		7.0	6.0	DO-35	3-55
BAY73	125	5.0		100	1.0		200	8.0	DO-35	3-9
1N483B	80	25		70	1.0		100	—	DO-35	3-57
1N457	70	25		60	1.0		20	8.0	DO-35	3-55
1N457A	70	25		60	1.0		100	—	DO-35	3-55
1N482B	40	25		36	1.0		100	—	DO-35	3-57
FJT1100	30	0.001		5.0	1.05		10	1.5	DO-7	3-33
1N456A	30	25		25	1.0		100	—	DO-35	3-55
1N456	30	25		25	1.0		40	10	DO-35	3-55

FAIRCHILD DIODES

DIODES

HIGH VOLTAGE SWITCHING DIODES (BY DESCENDING BV) GLASS PACKAGE

DEVICE NO.	BV V Min	I _R nA Max	@	V _R V	V _F V Max	@	I _F mA	C pF Max	t _{rr} ns Max	Package No.	Page No.
BAV21	250	100		200	1.0		100	—	50	DO-35	3-3
1N661	240	10000		200	1.0		6.0	—	300	DO-35	3-60
FDH400	200	100		150	1.0		200	2.0	50	DO-35	3-27
1N3070	200	100		175	1.0		100	5.0	50	DO-35	3-65
1N4938	200	100		175	1.0		100	5.0	50	DO-35	3-65
BAV20	200	100		150	1.0		100	—	50	DO-35	3-3
1N629	200	1000		175	1.5		4.0	—	1000	DO-35	3-58
FDH444	150	50		100	1.1		200	2.5	60	DO-35	3-27
1N628	150	1000		125	1.5		4.0	—	1000	DO-35	3-58
BAY72	125	100		100	1.0		100	5.0	50	DO-35	3-8
BAY80	120	100		120	1.0		150	6.0	—	DO-35	3-8
BAV19	120	100		100	1.0		100	—	50	DO-35	3-3
1N658	120	50		50	1.0		100	—	300	DO-35	3-59
1N660	120	5000		100	1.0		6.0	—	300	DO-35	3-60
1N627	100	1000		75	1.5		4.0	—	1000	DO-35	3-58
1N626	50	1000		35	1.5		4.0	—	1000	DO-35	3-58

GENERAL PURPOSE DIODES (BY DESCENDING BV) GLASS PACKAGE

DEVICE NO.	BV V Min	I _R nA Max	@	V _R V	V _F V Max	@	I _F mA	C pF Max	t _{rr} ns Max	Package No.	Page No.
1N661	240	10000		200	1.0		6.0	—	300	DO-35	3-60
1S923	200	100		200	1.2		200	—	—	DO-35	3-86
1N463A	200	500		175	1.0		100	—	—	DO-35	3-56
BA129	200	10		180	1.0		50	6.0	—	DO-35	3-9
1S922	150	100		150	1.2		200	—	—	DO-35	3-86
BAX16	150	100		150	1.0		1.0	10	120	DO-35	3-6
1N660	120	5000		100	1.0		6.0	—	—	DO-35	3-60
1S921	100	100		100	1.2		200	—	—	DO-35	3-86
BA219	100	200		50	0.85		10	5.0	—	DO-35	3-14
BA128	75	100		50	1.0		50	5.0	—	DO-35	3-12
1N462A	70	500		60	1.0		100	—	—	DO-35	3-56
BAV18	60	100		50	1.0		100	—	50	DO-35	3-3
1N659	60	5000		50	1.0		6.0	—	—	DO-35	3-60
1S920	50	100		50	1.2		200	—	—	DO-35	3-86

FAIRCHILD DIODES

DIODES

GENERAL PURPOSE DIODES (BY DESCENDING BV) GLASS PACKAGE

DEVICE NO.	BV V Min	I _R nA Max	@	V _R V	V _F V Max	@	I _F mA	C pF Max	t _{rr} ns Max	Package No.	Page No.
BA218	50	50		25	1.0		10	5.0	—	DO-35	3-14
1S44	50	50		10	1.15		10	6.0	—	DO-35	3-85
FDH900	45	500		40	1.1		100	3.0	4.0	DO-35	3-29
FDH999	35	1000		25	1.0		10	5.0	5.0	DO-35	3-29
1N461A	30	500		25	1.0		100	10	—	DO-35	3-56
BA217	30	50		10	1.0		10	5.0	—	DO-35	3-14
BA130	30	100		25	1.0		10	2.0	—	DO-35	3-12
BAV17	25	100		20	1.0		100	—	50	DO-35	3-3
BA216	10	1500		10	1.0		15	—	—	DO-35	3-14

MILITARY QUALIFIED SMALL SIGNAL DIODES (NUMERIC LISTING) GLASS PACKAGE

DEVICE NO.	BV V Min	I _R nA Max	@	V _R V	V _F V Max	@	I _F mA	C pF Max	t _{rr} ns Max	Package No.	Page No.
1N457JAN	70	25		60	1.0		20	6.0	—	DO-7	3-55
1N458JAN	150	25		125	1.0		7.0	6.0	—	DO-7	3-55
1N459JAN	200	25		175	1.0		3.0	6.0	—	DO-7	3-55
1N483BJAN	80	25		70	1.0		100	—	—	DO-7	3-57
1N483BJANTX	80	25		70	1.0		100	—	—	DO-7	3-57
1N485BJAN	200	25		180	1.0		100	—	—	DO-7	3-57
1N485BJANTX	200	25		180	1.0		100	—	—	DO-7	3-57
1N486BJAN	250	25		225	1.0		100	—	—	DO-7	3-57
1N486BJANTX	250	25		225	1.0		100	—	—	DO-7	3-57
1N914JAN	100	25		20	1.0		10	4.0	4.0	DO-35	3-62
1N914JANTX	100	25		20	1.0		10	4.0	4.0	DO-35	3-62
1N3064JAN	75	100		50	1.0		10	2.0	4.0	DO-7	3-62
1N3064JANTX	75	100		50	1.0		10	2.0	4.0	DO-7	3-64
1N3595JAN	150	1.0		125	1.0		200	8.0	3000	DO-7	3-66
1N3595JANTX	150	1.0		125	1.0		200	8.0	3000	DO-7	3-66
1N3595JANTXV	150	1.0		125	1.0		200	8.0	3000	DO-7	3-66
1N3600JAN	75	100		50	1.0		200	2.5	4.0	DO-7	3-67
1N3600JANTX	75	100		50	1.0		200	2.5	4.0	DO-7	3-67

FAIRCHILD DIODES

DIODES

**MILITARY QUALIFIED SMALL SIGNAL DIODES (NUMERIC LISTING)
GLASS PACKAGE**

DEVICE NO.	BV V Min	I _R nA Max	@	V _R V	V _F V Max	@	I _F mA	C pF Max	t _{rr} ns Max	Package No.	Page No.
1N3600JANTXV	75	100		50	1.0		200	2.5	4.0	DO-7	3-67
1N4148JAN	100	25		20	1.0		10	4.0	4.0	DO-35	3-62
1N4148JANTX	100	25		20	1.0		10	4.0	4.0	DO-35	3-62
1N4148JANTXV	100	25		20	1.0		10	4.0	4.0	DO-35	3-62
1N4148-1JAN	100	25		20	1.0		10	4.0	4.0	DO-35	3-62
1N4148-1JANTX	100	25		20	1.0		10	4.0	4.0	DO-35	3-62
1N4148-1JANTXV	100	25		20	1.0		10	4.0	4.0	DO-35	3-62
1N4150JAN	75	100		50	1.0		200	2.5	4.0	DO-35	3-67
1N4150JANTX	75	100		50	1.0		200	2.5	4.0	DO-35	3-67
1N4150JANTXV	75	100		50	1.0		200	2.5	4.0	DO-35	3-67
1N4150-1JAN	75	100		50	1.0		200	2.5	4.0	DO-35	3-67
1N4150-1JANTX	75	100		50	1.0		200	2.5	4.0	DO-35	3-67
1N4150-1JANTXV	75	100		50	1.0		200	2.5	4.0	DO-35	3-67
1N4376JAN	20	100		10	1.1		50	1.0	0.75	DO-7	3-11
1N4376JANTX	20	100		10	1.1		50	1.0	0.75	DO-7	3-11
1N4454JAN	75	100		50	1.0		10	2.0	4.0	DO-35	3-64
1N4454JANTX	75	100		50	1.0		10	2.0	4.0	DO-35	3-64
1N4454JANTXV	75	100		50	1.0		10	2.0	4.0	DO-35	3-64
1N4454-1JAN	75	100		50	1.0		10	2.0	4.0	DO-35	3-64
1N4454-JANTX	75	100		50	1.0		10	2.0	4.0	DO-35	3-64
1N4454-1JANTXV	75	100		50	1.0		10	2.0	4.0	DO-35	3-64

**HOT CARRIER DIODE
GLASS PACKAGE**

DEVICE NO.	BV V Min	I _R nA Max	@	V _R V	V _F V Max.	@	I _F mA	C pF Max	NF dB Max	Package No.	Page No.
FH1100	5.0	1000		1.0	0.55		10	1.0	10	DO-7	3-32
1N5390	5.0	50		1.0	0.55		10	1.0	10	DO-7	3-32

1

FAIRCHILD DIODES

DIODES

VOLTAGE VARIABLE CAPACITOR DIODES GLASS PACKAGE

DEVICE NO.	BV V Min	I _R nA Max	@ V	V _R V	C pF Typ	Figure of Merit (Q) Min	C1/C4 V _{R1} = 0.1V V _{R4} = 4.0V Min	C3/C20 V _{R3} = 3V V _{R20} = 20V Min	Package No.	Page No.
RF400	35	30	30	10	350	2.0	2.0	DO-35	3-51	
RF401	35	30	30	7.0	350	2.0	2.0	DO-35	3-51	

DEVICE NO.	BV V Min	I _R nA Max	@ V	V _R V	C pF V _R =3V	C pF V _R =25V	C ₃ /C ₂₅ V _R =3V V _R =25V	Package No.	Page No.
BB121A	30	50	28	11	2.2	5.2	DO-35	3-16	
BB121B	30	50	28	12	2.45	5.2	DO-35	3-16	
BB122	30	50	28	13	2.45	5.2	DO-35	3-16	
BB139	30	50	28	29	5.1	5.7	DO-35	3-17	

PLASTIC PACKAGE

DEVICE NO.	BV V Min	I _R nA Max	@ V	V _R V	C pF Min-Max	Figure of Merit (Q) Min	C ₃ /C ₃₀ V _{R3} = 3.0V V _{R30} = 30V	Package No.	Page No.
BB204B	—	50	30	37-42	—	2.4-2.8	TO-92	3-18	
BB204G	—	50	30	34-39	—	2.4-2.8	TO-92	3-18	
MV104	32	50	30	37-42	100	2.5-2.8	TO-92	3-18	
RF500	35	50	30	38-42	125	2.5-2.8	TO-92	3-52	

BANDSWITCH DIODES GLASS PACKAGE

DEVICE NO.	BV V Min	I _R nA Max	@ V	V _R V	C pF Max	R _S Ω Max	V _F V Max	@ mA	Package No.	Page No.
BA243	20	100	15	2.0	1.0	1.0	100	DO-35	3-15	
BA244	20	100	15	2.0	0.5	1.0	100	DO-35	3-15	

ZENER DIODES (BY ASCENDING V_Z) GLASS PACKAGE

DEVICE NO.	V _Z V Nom	Tol. ±V _Z %	Z _Z Ω Max	@I _Z mA	I _R μA Max	@ V _R V	T.C. %/°C Typ (Max)	P _D mW T _A =25°C	Package No.	Page No.
1N746A	3.3	5	28	20	10	1.0	-0.070	500	DO-35	3-61
1N4620	3.3	5	1650	0.25	7.5	1.5	—	500	DO-35	3-70
1N5226B	3.3	5	28	20	25	1.0	(-0.070)	500	DO-35	3-78
BZX55C3V3	3.3	5	85	5.0	40	1.0	-0.060	500	DO-35	3-19
BZY88C3V3	3.3	5	22	20	3.0	1.0	(-0.091)	500	DO-35	3-21
ZPD3,3	3.3	5	90	5.0	—	—	(-0.080)	500	DO-35	3-53

Tolerance: All zener diodes are also available in ±1%, ±2%, ±10% and ±20% tolerances.

FAIRCHILD DIODES

DIODES

ZENER DIODES (BY ASCENDING V_Z) GLASS PACKAGE

DEVICE NO.	V _Z V Nom	Tol. ± V _Z %	Z _Z Ω Max	@I _Z mA	I _R μA Max	@	V _R V	T.C. %/°C Typ (Max)	P _D mW T _A =25°C	Package No.	Page No.
1N4728A	3.3	5	10	76	100		1.0	—	1000	DO-41	3-75
BZX85C3V3	3.3	5	20	80	40		1.0	-.065	1000	DO-41	3-20
1N747A	3.6	5	24	20	10		1.0	-.065	500	DO-35	3-61
1N4621	3.6	5	1700	0.25	7.5		2.0	—	500	DO-35	3-70
1N5227B	3.6	5	24	20	15		1.0	(-.065)	500	DO-35	3-78
BZX55C3V6	3.6	5	85	5.0	40		1.0	-.055	500	DO-35	3-19
BZY88C3V6	3.6	5	20	20	3.0		1.0	(-.069)	500	DO-35	3-21
ZPD3,6	3.6	5	90	5.0	—		—	(-.080)	500	DO-35	3-53
1N4729A	3.6	5	10	69	100		1.0	—	1000	DO-41	3-75
BZX85C3V6	3.6	5	15	60	20		1.0	-.065	1000	DO-41	3-20
1N748A	3.9	5	23	20	10		1.0	-.060	500	DO-35	3-61
1N4622	3.9	5	1650	0.25	5.0		2.0	—	500	DO-35	3-70
1N5228B	3.9	5	23	20	10		1.0	(-.060)	500	DO-35	3-78
BZX55C3V9	3.9	5	80	5.0	40		1.0	-.050	500	DO-35	3-19
BZY88C3V9	3.9	5	18	20	3.0		1.0	(-.062)	500	DO-35	3-21
ZPD3,9	3.9	5	90	5.0	—		—	(-.070)	500	DO-35	3-53
1N4730A	3.9	5	9.0	64	50		1.0	—	1000	DO-41	3-75
BZX85C3V9	3.9	5	15	60	10		1.0	-.045	1000	DO-41	3-20
1N749A	4.3	5	22	20	2.0		1.0	±.055	500	DO-35	3-61
1N4623	4.3	5	1600	0.25	4.0		2.0	—	500	DO-35	3-70
1N5229B	4.3	5	22	20	5.0		1.0	(±.055)	500	DO-35	3-78
BZX55C4V3	4.3	5	70	5.0	40		1.5	-.040	500	DO-35	3-19
BZY88C4V3	4.3	5	17	20	3.0		1.0	(-.047)	500	DO-35	3-21
ZPD4,3	4.3	5	90	5.0	—		—	(-.060)	500	DO-35	3-53
1N4731A	4.3	5	9.0	58	10		1.0	—	1000	DO-41	3-75
BZX85C4V3	4.3	5	13	50	3.0		1.0	-.020	1000	DO-41	3-20
1N750A	4.7	5	19	20	2.0		1.0	±.043	500	DO-35	3-61
1N4624	4.7	5	1550	0.25	10		3.0	—	500	DO-35	3-70
1N5230B	4.7	5	19	20	5.0		2.0	(±.030)	500	DO-35	3-78
BZX55C4V7	4.7	5	60	5.0	30		1.5	-.020	500	DO-35	3-19
BZY88C4V7	4.7	5	17	20	3.0		2.0	(-.032)	500	DO-35	3-21
ZPD4,7	4.7	5	78	5.0	—		—	(-.050)	500	DO-35	3-53
1N4732A	4.7	5	8.0	53	10		1.0	—	1000	DO-41	3-75
BZX85C4V7	4.7	5	13	45	3.0		1.5	+.005	1000	DO-41	3-20
1N751A	5.1	5	17	20	1.0		1.0	±.030	500	DO-35	3-61
1N4625	5.1	5	1500	0.25	10		3.0	—	500	DO-35	3-70

Tolerance: All zener diodes are also available in ± 1%, 2±%, ± 10% and ± 20% tolerances.

1

FAIRCHILD DIODES

DIODES

ZENER DIODES (BY ASCENDING V_Z) GLASS PACKAGE

DEVICE NO.	V _Z V Nom	Tol. ±V _Z %	Z _Z Ω Max	@I _Z mA	I _R μA Max	@	V _R V	T.C. %/°C Typ (Max)	P _D mW T _A =25°C	Package No.	Page No.
1N5231B	5.1	5	17	20	5.0		2.0	(±.030)	500	DO-35	3-78
BZX55C5V1	5.1	5	35	5.0	2.0		1.0	+0.10	500	DO-35	3-19
BZY88C5V1	5.1	5	11	20	1.0		2.0	(-.030)	500	DO-35	3-21
ZPD5,1	5.1	5	60	5.0	0.1		0.8	(+.040)	500	DO-35	3-53
1N4733A	5.1	5	7.0	49	10		1.0	—	1000	DO-41	3-75
BZX85C5V1	5.1	5	10	45	1.0		2.0	+0.10	1000	DO-41	3-20
1N752A	5.6	5	11	20	1.0		1.0	+0.28	500	DO-35	3-61
1N4626	5.6	5	1400	0.25	10		4.0	—	500	DO-35	3-70
1N5232B	5.6	5	11	20	5.0		3.0	(±.038)	500	DO-35	3-78
BZX55C5V6	5.6	5	25	5.0	2.0		1.0	+0.25	500	DO-35	3-19
BZY88C5V6	5.6	5	8	20	1.0		2.0	(+.054)	500	DO-35	3-21
ZPD5,6	5.6	5	40	5.0	0.1		1.0	(+.060)	500	DO-35	3-53
1N4734A	5.6	5	5.0	45	10		2.0	—	1000	DO-41	3-75
BZX85C5V6	5.6	5	7.0	45	1.0		2.0	+0.25	1000	DO-41	3-20
1N5233B	6.0	5	7.0	20	5.0		3.5	(+.038)	500	DO-35	3-78
1N753A	6.2	5	7.0	20	0.1		1.0	+0.45	500	DO-35	3-61
1N4627	6.2	5	1200	0.25	10		5.0	—	500	DO-35	3-70
1N5234B	6.2	5	7.0	20	5.0		4.0	(+.045)	500	DO-35	3-78
BZX55C6V2	6.2	5	10	5.0	2.0		2.0	+0.32	500	DO-35	3-19
BZY88C6V2	6.2	5	3.1	20	1.0		2.0	(+.065)	500	DO-35	3-21
ZPD6,2	6.2	5	10	5.0	0.1		2.0	(+.070)	500	DO-35	3-53
1N4735A	6.2	5	2.0	41	10		3.0	—	1000	DO-41	3-75
BZX85C6V2	6.2	5	4.0	35	1.0		3.0	+0.32	1000	DO-41	3-20
1N754A	6.8	5	5.0	20	0.1		1.0	+0.50	500	DO-35	3-61
1N957B	6.8	5	4.5	18.5	150		5.2	+0.50	500	DO-35	3-63
1N4099	6.8	5	200	0.25	10		5.2	—	500	DO-35	3-70
1N5235B	6.8	5	5.0	20	3.0		5.0	(+.050)	500	DO-35	3-78
BZX55C6V8	6.8	5	8.0	5.0	2.0		3.0	+0.40	500	DO-35	3-19
BZY88C6V8	6.8	5	3.0	20	1.0		3.0	(+.070)	500	DO-35	3-21
ZPD6,8	6.8	5	8.0	5.0	0.1		3.0	(+.070)	500	DO-35	3-53
1N4736A	6.8	5	3.5	37	10		4.0	—	1000	DO-41	3-75
BZX85C6V8	6.8	5	3.5	35	1.0		4.0	+0.40	1000	DO-41	3-20
1N755A	7.5	5	6.0	20	0.1		1.0	+0.58	500	DO-35	3-61

Tolerance: All zener diodes are also available in ±1%, ±2%, ±10%, and ±20% tolerances.

FAIRCHILD DIODES

DIODES

ZENER DIODES (BY ASCENDING V_Z) GLASS PACKAGE

DEVICE NO.	V _Z V Nom	Tol. ± V _Z %	Z _Z Ω Max	@I _Z mA	I _R μA Max	@	V _R V	T.C. %/°C Typ (Max)	P _D mW T _A =25°C	Package No.	Page No.
1N958B	7.5	5	5.5	16.5	75		5.7	+ .058	500	DO-35	3-63
1N4100	7.5	5	200	0.25	10		5.7	—	500	DO-35	3-70
1N5236B	7.5	5	6.0	20	3.0		6.0	(+ .058)	500	DO-35	3-78
BZX55C7V5	7.5	5	7.0	5.0	2.0		5.0	+ .045	500	DO-35	3-19
BZY88C7V5	7.5	5	5.0	20	0.5		3.0	(+ .079)	500	DO-35	3-21
ZPD7,5	7.5	5	7.0	5.0	0.1		5.0	(+ .070)	500	DO-35	3-53
1N4737A	7.5	5	4.0	34	10		5.0	—	1000	DO-41	3-75
BZX85C7V5	7.5	5	3.0	35	1.0		4.5	+ .045	1000	DO-41	3-20
1N756A	8.2	5	8.0	20	0.1		1.0	+ .062	500	DO-35	3-61
1N4101	8.2	5	200	0.25	1.0		6.3	—	500	DO-35	3-70
1N959B	8.2	5	6.5	15	50		6.2	+ .062	500	DO-35	3-63
1N5237B	8.2	5	8.0	20	3.0		6.5	(+ .062)	500	DO-35	3-78
BZX55C8V2	8.2	5	7.0	5.0	2.0		6.0	+ .048	500	DO-35	3-19
BZY88C8V2	8.2	5	6.0	20	0.4		3.0	(+ .073)	500	DO-35	3-21
ZPD8,2	8.2	5	7.0	5.0	0.1		6.0	(+ .070)	500	DO-35	3-53
1N4738A	8.2	5	4.5	31	10		6.0	—	1000	DO-41	3-75
BZX85C8V2	8.2	5	5.0	25	1.0		5.0	+ .048	1000	DO-41	3-20
1N4102	8.7	5	200	0.25	1.0		6.7	—	500	DO-35	3-70
1N5238B	8.7	5	8.0	20	3.0		6.5	(+ .065)	500	DO-35	3-78
1N757A	9.1	5	10	20	0.1		1.0	+ .068	500	DO-35	3-61
1N960B	9.1	5	7.5	14	25		6.9	+ .068	500	DO-35	3-63
1N4103	9.1	5	200	0.25	1.0		7.0	—	500	DO-35	3-70
1N5239B	9.1	5	10	20	3.0		7.0	(+ .068)	500	DO-35	3-78
BZX55C9V1	9.1	5	10	5.0	2.0		7.0	+ .050	500	DO-35	3-19
BZY88C9V1	9.1	5	7.0	20	0.4		5.0	(+ .077)	500	DO-35	3-21
ZPD9,1	9.1	5	10	5.0	0.1		7.0	(+ .080)	500	DO-35	3-53
1N4739A	9.1	5	5.0	28	10		7.0	—	1000	DO-41	3-75
BZX85C9V1	9.1	5	5.0	25	1.0		6.5	+ .051	1000	DO-41	3-20
1N758A	10	5	17	20	0.1		1.0	+ .075	500	DO-35	3-61
1N961B	10	5	8.5	12.5	10		7.6	+ .072	500	DO-35	3-63
1N4104	10	5	200	0.25	1.0		7.6	—	500	DO-35	3-70
1N5240B	10	5	17	20	3.0		8.0	(+ .075)	500	DO-35	3-78
BZX55C10	10	5	15	5.0	2.0		7.5	+ .055	500	DO-35	3-19
BZY88C10	10	5	25	5.0	2.5		6.7	(+ .072)	500	DO-35	3-21
ZPD10	10	5	15	5.0	0.1		7.5	(+ .080)	500	DO-35	3-53

*Tolerance: All zener diodes are also available in ± 1%, ± 2%, ± 10% and ± 20% tolerances.

1

FAIRCHILD DIODES

DIODES

ZENER DIODES (BY ASCENDING V_Z) GLASS PACKAGE

DEVICE NO.	V_Z V Nom	Tol. $\pm V_Z$ %	Z_Z Ω Max	I_Z mA	I_R μ A Max	@	V_R V	T.C. %/°C Typ (Max)	P_D mW $T_A=25^\circ\text{C}$	Package No.	Page No.
1N4740A	10	5	7.0	25	10		7.6	—	1000	DO-41	3-75
BZX85C10	10	5	7.0	25	0.5		7.0	+0.055	1000	DO-41	3-20
1N962B	11	5	9.5	11.5	5.0		8.4	+0.073	500	DO-35	3-63
1N4105	11	5	200	0.25	0.05		8.5	—	500	DO-35	3-70
1N5241B	11	5	22	20	2.0		8.4	(+0.076)	500	DO-35	3-78
BZX55C11	11	5	20	5.0	2.0		8.5	+0.060	500	DO-35	3-19
BZY88C11	11	5	35	5.0	2.5		7.37	(+0.073)	500	DO-35	3-21
ZPD11	11	5	20	5.0	0.1		8.5	(+0.090)	500	DO-35	3-53
1N4741A	11	5	8.0	23	5.0		8.4	—	1000	DO-41	3-75
BZX85C11	11	5	8.0	20	0.5		7.7	+0.060	1000	DO-41	3-20
1N759A	12	5	30	20	0.1		1.0	+0.077	500	DO-35	3-61
1N963B	12	5	11.5	10.5	5.0		9.1	+0.076	500	DO-35	3-63
1N4106	12	5	200	0.25	0.05		9.2	—	500	DO-35	3-70
1N5242B	12	5	30	20	1.0		9.1	(+0.077)	500	DO-35	3-78
BZX55C12	12	5	20	5.0	2.0		9.0	+0.065	500	DO-35	3-19
BZY88C12	12	5	35	5.0	2.5		8.04	(+0.076)	500	DO-35	3-21
ZPD12	12	5	20	5.0	0.1		9.0	(+0.090)	500	DO-35	3-53
1N4742A	12	5	9.0	21	5.0		9.1	—	1000	DO-41	3-75
BZX85C12	12	5	9.0	20	0.5		8.4	+0.065	1000	DO-41	3-20
1N964B	13	5	13	9.5	5.0		9.9	+0.079	500	DO-35	3-63
1N4107	13	5	200	0.25	0.05		9.9	—	500	DO-35	3-70
1N5243B	13	5	13	9.5	0.5		9.9	(+0.079)	500	DO-35	3-78
BZX55C13	13	5	26	5.0	2.0		10	+0.070	500	DO-35	3-19
BZY88C13	13	5	35	5.0	2.5		8.71	(+0.079)	500	DO-35	3-21
ZPD13	13	5	25	5.0	0.1		10	(+0.090)	500	DO-35	3-53
1N4743A	13	5	10	19	5.0		9.9	—	1000	DO-41	3-75
BZX85C13	13	5	10	20	0.5		9.1	+0.065	1000	DO-41	3-20
1N4108	14	5	200	0.25	0.05		10.7	—	500	DO-35	3-70
1N5244B	14	5	15	9.0	0.1		10	(+0.082)	500	DO-35	3-78
1N965B	15	5	16	8.5	5.0		11.4	+0.082	500	DO-35	3-63
1N4109	15	5	100	0.25	0.05		11.4	—	500	DO-35	3-70
1N5245B	15	5	16	8.5	0.1		11	(+0.082)	500	DO-35	3-78
BZX55C15	15	5	30	5.0	2.0		11	+0.070	500	DO-35	3-19
BZY88C15	15	5	40	5.0	2.5		10.05	(+0.082)	500	DO-35	3-21
ZPD15	15	5	30	5.0	0.1		11	(+0.090)	500	DO-35	3-53

* Tolerance: All zener diodes are also available in $\pm 1\%$, $\pm 2\%$, $\pm 10\%$ and $\pm 20\%$ tolerances.

FAIRCHILD DIODES

DIODES

ZENER DIODES (BY ASCENDING VZ) GLASS PACKAGE

DEVICE NO.	VZ V Nom	Tol. ± VZ %	ZZ Ω Max	@Iz mA	IR μA Max	@	VR V	T.C. %/°C Typ (Max)	Pd mW TA=25°C	Package No.	Page No.
1N4744A	15	5	14	17	5.0		11.4	—	1000	DO-41	3-75
BZX85C15	15	5	15	15	0.5		10.5	+0.070	1000	DO-41	3-20
1N966B	16	5	17	7.8	5.0		12.2	+0.083	500	DO-35	3-63
1N4110	16	5	100	0.25	0.05		12.2	—	500	DO-35	3-70
1N5246B	16	5	17	7.8	0.1		12	(+0.083)	500	DO-35	3-78
BZX55C16	16	5	40	5.0	2.0		12	+0.075	500	DO-35	3-19
BZY88C16	16	5	45	5.0	2.5	10.72		(+0.083)	500	DO-35	3-21
ZPD16	16	5	40	5.0	0.1		12	(+0.095)	500	DO-35	3-53
1N4745A	16	5	16	15.5	5.0		12.2	—	1000	DO-41	3-75
BZX85C16	16	5	15	15	0.5		11.0	+0.070	1000	DO-41	3-20
1N4111	17	5	100	0.25	0.05		13.0	—	500	DO-35	3-70
1N5247B	17	5	19	7.4	0.1		13	(+0.084)	500	DO-35	3-78
1N4112	18	5	100	0.25	0.05		13.7	—	500	DO-35	3-63
1N967B	18	5	21	7.0	5.0		13.7	+0.085	500	DO-35	3-70
1N5248B	18	5	21	7.0	0.1		14	(+0.085)	500	DO-35	3-78
BZX55C18	18	5	55	5.0	2.0		14	+0.075	500	DO-35	3-19
BZY88C18	18	5	50	5.0	2.5	12.06		(+0.085)	500	DO-35	3-21
ZPD18	18	5	50	5.0	0.1		14	(+0.095)	500	DO-35	3-53
1N4746A	18	5	20	14	5.0		13.7	—	1000	DO-41	3-75
BZX85C18	18	5	20	15	0.5		12.5	+0.075	1000	DO-41	3-20
1N4113	19	5	150	0.25	0.05		14.5	—	500	DO-35	3-17
1N5249B	19	5	23	6.6	0.1		14	(+0.086)	500	DO-35	3-78
1N968B	20	5	25	6.2	5.0		15.2	+0.086	500	DO-35	3-63
1N4114	20	5	150	0.25	0.01		15.2	—	500	DO-35	3-70
1N5250B	20	5	25	6.2	0.1		15	(+0.086)	500	DO-35	3-78
BZX55C20	20	5	55	5.0	2.0		15	+0.080	500	DO-35	3-19
BZY88C20	20	5	60	5.0	2.5	13.4		(+0.086)	500	DO-35	3-21
ZPD20	20	5	50	5.0	0.1		15	(+0.100)	500	DO-35	3-53
1N4747A	20	5	22	12.5	5.0		15.2	—	1000	DO-41	3-75
BZX85C20	20	5	24	10	0.5		14	+0.075	1000	DO-41	3-20
1N969B	22	5	29	5.6	5.0		16.7	+0.087	500	DO-35	3-63
1N4115	22	5	150	0.25	0.01		16.8	—	500	DO-35	3-70
1N5251B	22	5	29	5.6	0.1		17	(+0.087)	500	DO-35	3-78
BZX55C22	22	5	55	5.0	2.0		17	+0.080	500	DO-35	3-19
BZY88C22	22	5	65	5.0	2.5	14.74		(+0.087)	500	DO-35	3-21
ZPD22	22	5	55	5.0	0.1		17	(+0.100)	500	DO-35	3-53
1N4748A	22	5	23	11.5	5.0		16.7	—	1000	DO-41	3-75

* Tolerance: All zener diodes are also available in ±1%, ±2%, ±10% and ±20% tolerance.

1

FAIRCHILD DIODES

DIODES

ZENER DIODES (BY ASCENDING Vz) GLASS PACKAGE

DEVICE NO.	Vz V Nom	Tol. ± Vz %	Zz Ω Max	@Iz mA	Ir μA Max	@	VR V	T.C. %/°C Typ (Max)	Pd mW TA=25°C	Package No.	Page No.
BZX85C22	22	5	25	10	0.5		15.5	+080	1000	DO-41	3-20
1N970B	24	5	33	5.2	5.0		18.2	+088	500	DO-35	3-63
1N4116	24	5	150	0.25	0.01		18.3	—	500	DO-35	3-70
1N5252B	24	5	33	5.2	0.1		18	(+088)	500	DO-35	3-78
BZX55C24	24	5	80	5.0	2.0		18	+085	500	DO-35	3-19
BZY88C24	24	5	75	5.0	2.5		16.08	(+088)	500	DO-35	3-21
ZPD24	24	5	80	5.0	0.1		18	(+100)	500	DO-35	3-53
1N4749A	24	5	25	10.5	5.0		18.2	—	1000	DO-41	3-75
BZX85C24	24	5	25	10	0.5		17	+080	1000	DO-41	3-20
1N4117	25	5	150	0.25	0.01		19.0	—	500	DO-35	3-70
1N5253B	25	5	35	5.0	0.1		19	(+089)	500	DO-35	3-78
1N971B	27	5	41	4.6	5.0		20.6	+090	500	DO-35	3-63
1N4118	27	5	150	0.25	0.01		20.5	—	500	DO-35	3-70
1N5254B	27	5	41	4.6	0.1		21	(+090)	500	DO-35	3-78
BZX55C27	27	5	80	5.0	2.0		20	+085	500	DO-35	3-19
BZY88C27	27	5	85	5.0	2.5		18.09	(+090)	500	DO-35	3-21
ZPD27	27	5	80	5.0	0.1		20	(+100)	500	DO-35	3-53
1N4750A	27	5	35	9.5	5.0		20.6	—	1000	DO-41	3-75
BZX85C27	27	5	30	8.0	0.5		19	+085	1000	DO-41	3-20
1N4119	28	5	200	0.25	0.01		21.3	—	500	DO-35	3-70
1N5255B	28	5	44	4.5	0.1		21	(+091)	500	DO-35	3-78
1N972B	30	5	49	4.2	5.0		22.8	+091	500	DO-35	3-63
1N4120	30	5	200	0.25	0.01		22.8	—	500	DO-35	3-70
1N5256B	30	5	49	4.2	0.1		23	(+091)	500	DO-35	3-78
BZX55C30	30	5	80	5.0	2.0		22	+085	500	DO-35	3-19
BZY88C30	30	5	95	5.0	2.5		20.1	(+091)	500	DO-35	3-21
ZPD30	30	5	80	5.0	0.1		22.5	(+100)	500	DO-35	3-53
1N4751A	30	5	40	8.5	5.0		22.8	—	1000	DO-41	3-75
BZX85C30	30	5	30	8.0	0.5		21	+085	1000	DO-41	3-20
1N973B	33	5	58	3.8	5.0		25.1	+092	500	DO-35	3-63
1N4121	33	5	200	0.25	0.01		25.1	—	500	DO-35	3-70
1N5257B	33	5	58	3.8	0.1		25	(+092)	500	DO-35	3-78
BZX55C33	33	5	80	5.0	2.0		24	+085	500	DO-35	3-19
BZY88C33	33	5	120	5.0	2.5		21	(+100)	500	DO-35	3-21
ZPD33	33	5	80	5.0	0.1		25	(+100)	500	DO-35	3-53
1N4752A	33	5	45	7.5	5.0		25.1	—	1000	DO-41	3-75
BZX85C33	33	5	35	8.0	0.5		23	+085	1000	DO-41	3-20

* Tolerance: All zener diodes are also available in ±1%, ±2%, ±10% and ±20% tolerances.

FAIRCHILD DIODES

DIODES

MILITARY QUALIFIED ZENER DIODES
GLASS PACKAGE

DEVICE NO.	V _Z V Nom	Tol. ±V _Z %	Z _Z Ω Max	@I _Z mA	I _R μA Max	@	V _R V	T.C. %/°C Max	P _D mW T _A =25°C	Package No.	Page No.
1N747AJAN	3.6	5	22	20	3.0		1.0	-.065	400	DO-7	3-61
1N747AJANTX	3.6	5	22	20	3.0		1.0	-.065	400	DO-7	3-61
1N747AJANTXV	3.6	5	22	20	3.0		1.0	-.065	400	DO-7	3-61
1N748AJAN	3.9	5	20	20	2.0		1.0	-.060	400	DO-7	3-61
1N748AJANTX	3.9	5	20	20	2.0		1.0	-.060	400	DO-7	3-61
1N748AJANTXV	3.9	5	20	20	2.0		1.0	-.060	400	DO-7	3-61
1N749AJANTXV	4.3	5	18	20	2.0		1.0	-.055	400	DO-7	3-61
1N749AJANTX	4.3	5	18	20	2.0		1.0	-.055	400	DO-7	3-61
1N749AJANTX	4.3	5	18	20	2.0		1.0	-.055	400	DO-7	3-61
1N750AJAN	4.7	5	16	20	5.0		1.5	-.043	400	DO-7	3-61
1N750AJANTX	4.7	5	16	20	5.0		1.5	-.043	400	DO-7	3-61
1N750AJANTXV	4.7	5	16	20	5.0		1.5	-.043	400	DO-7	3-61
1N751AJAN	5.1	5	14	20	5.0		2.0	±.030	400	DO-7	3-61
1N751AJANTX	5.1	5	14	20	5.0		2.0	±.030	400	DO-7	3-61
1N751AJANTXV	5.1	5	14	20	5.0		2.0	±.030	400	DO-7	3-61
1N752AJAN	5.6	5	8.0	20	5.0		2.5	+.032	400	DO-7	3-61
1N752AJANTX	5.6	5	8.0	20	5.0		2.5	+.032	400	DO-7	3-61
1N752AJANTXV	5.6	5	8.0	20	5.0		2.5	+.032	400	DO-7	3-61
1N753AJAN	6.2	5	3.0	20	5.0		3.5	+.045	400	DO-35	3-61
1N753AJANTX	6.2	5	3.0	20	5.0		3.5	+.045	400	DO-35	3-61
1N753AJANTXV	6.2	5	3.0	20	5.0		3.5	+.045	400	DO-35	3-61
1N753A-1JAN	6.2	5	3.0	20	5.0		3.5	+.045	400	DO-35	3-61
1N753A-1JANTX	6.2	5	3.0	20	5.0		3.5	+.045	400	DO-35	3-61
1N753A-1JANTXV	6.2	5	3.0	20	5.0		3.5	+.045	400	DO-35	3-61
1N754AJAN	6.8	5	3.0	20	2.0		4.0	+.050	400	DO-35	3-61
1N754AJANTX	6.8	5	3.0	20	2.0		4.0	+.050	400	DO-35	3-61
1N754AJANTXV	6.8	5	3.0	20	2.0		4.0	+.050	400	DO-35	3-61
1N754A-1JAN	6.8	5	3.0	20	2.0		4.0	+.050	400	DO-35	3-61
1N754A-1JANTX	6.8	5	3.0	20	2.0		4.0	+.050	400	DO-35	3-61
1N754A-1JANTXV	6.8	5	3.0	20	2.0		4.0	+.050	400	DO-35	3-61
1N755AJAN	7.5	5	4.0	20	2.0		5.0	+.058	400	DO-35	3-61
1N755AJANTX	7.5	5	4.0	20	2.0		5.0	+.058	400	DO-35	3-61
1N755AJANTXV	7.5	5	4.0	20	2.0		5.0	+.058	400	DO-35	3-61
1N755A-1JAN	7.5	5	4.0	20	2.0		5.0	+.058	400	DO-35	3-61
1N755A-1JANTX	7.5	5	4.0	20	2.0		5.0	+.058	400	DO-35	3-61
1N755A-1JANTXV	7.5	5	4.0	20	2.0		5.0	+.058	400	DO-35	3-61
1N756AJAN	8.2	5	5.0	20	1.0		6.0	+.062	400	DO-35	3-61
1N756AJANTX	8.2	5	5.0	20	1.0		6.0	+.062	400	DO-35	3-61

1

FAIRCHILD DIODES

DIODES

MILITARY QUALIFIED ZENER DIODES
GLASS PACKAGE

DEVICE NO.	V _Z V Nom	Tol. ±V _Z %	Z _Z Ω Max	@I _Z mA	I _R μA Max	@	V _R V	T.C. %/°C Max	P _D mW T _A =25°C	Package No.	Page No.
1N756AJANTXV	8.2	5	5.0	20	1.0		6.0	+062	400	DO-35	3-61
1N756A-1JAN	8.2	5	5.0	20	1.0		6.0	+062	400	DO-35	3-61
1N756A-1JANTX	8.2	5	5.0	20	1.0		6.0	+062	400	DO-35	3-61
1N756A-1JANTXV	8.2	5	5.0	20	1.0		6.0	+062	400	DO-35	3-61
1N757AJAN	9.1	5	6.0	20	1.0		7.0	+068	400	DO-35	3-61
1N757AJANTX	9.1	5	6.0	20	1.0		7.0	+068	400	DO-35	3-61
1N757AJANTXV	9.1	5	6.0	20	1.0		7.0	+068	400	DO-35	3-61
1N757A-1JAN	9.1	5	6.0	20	1.0		7.0	+068	400	DO-35	3-61
1N757A-1JANTX	9.1	5	6.0	20	1.0		7.0	+068	400	DO-35	3-61
1N757A-1JANTXV	9.1	5	6.0	20	1.0		7.0	+068	400	DO-35	3-61
1N758AJAN	10	5	7.0	20	1.0		8.0	+075	400	DO-35	3-61
1N758AJANTX	10	5	7.0	20	1.0		8.0	+075	400	DO-35	3-61
1N758AJANTXV	10	5	7.0	20	1.0		8.0	+075	400	DO-35	3-61
1N758A-1JAN	10	5	7.0	20	1.0		8.0	+075	400	DO-35	3-61
1N758A-1JANTX	10	5	7.0	20	1.0		8.0	+075	400	DO-35	3-61
1N758A-1JANTXV	10	5	7.0	20	1.0		8.0	+075	400	DO-35	3-61
1N759AJAN	12	5	10	20	1.0		9.0	+080	400	DO-35	3-61
1N759AJANTX	12	5	10	20	1.0		9.0	+080	400	DO-35	3-61
1N759AJANTXV	12	5	10	20	1.0		9.0	+080	400	DO-35	3-61
1N759A-1JAN	12	5	10	20	1.0		9.0	+080	400	DO-35	3-61
1N759A-1JANTX	12	5	10	20	1.0		9.0	+080	400	DO-35	3-61
1N759A-1JANTXV	12	5	10	20	1.0		9.0	+080	400	DO-35	3-61
1N962BJAN	11	5	9.5	11.5	5.0		8.4	+073	400	DO-35	3-63
1N962BJANTX	11	5	9.5	11.5	5.0		8.4	+073	400	DO-35	3-63
1N962BJANTXV	11	5	9.5	11.5	5.0		8.4	+073	400	DO-35	3-63
1N962B-1JAN	11	5	9.5	11.5	5.0		8.4	+073	400	DO-35	3-63
1N962B-1JANTX	11	5	9.5	11.5	5.0		8.4	+073	400	DO-35	3-63
1N962B-1JANTXV	11	5	9.5	11.5	5.0		8.4	+073	400	DO-35	3-63
1N963BJAN	12	5	11.5	10.5	5.0		9.1	+076	400	DO-35	3-63
1N963BJANTX	12	5	11.5	10.5	5.0		9.1	+076	400	DO-35	3-63
1N963BJANTXV	12	5	11.5	10.5	5.0		9.1	+076	400	DO-35	3-63
1N963B-1JAN	12	5	11.5	10.5	5.0		9.1	+076	400	DO-35	3-63
1N963B-1JANTX	12	5	11.5	10.5	5.0		9.1	+076	400	DO-35	3-63
1N963B-1JANTXV	12	5	11.5	10.5	5.0		9.1	+076	400	DO-35	3-63
1N964BJAN	13	5	13	9.5	5.0		9.9	+079	400	DO-35	3-63
1N964BJANTX	13	5	13	9.5	5.0		9.9	+079	400	DO-35	3-63

FAIRCHILD DIODES

DIODES

MILITARY QUALIFIED ZENER DIODES GLASS PACKAGE

DEVICE NO.	V _Z V Nom	Tol. ±V _Z %	Z _Z Ω Max	@I _Z mA	I _R μA Max	@	V _R V	T.C. %/°C Max	P _D mW T _A =25°C	Package No.	Page No.
1N964BJANTXV	13	5	13	9.5	5.0		9.9	+0.079	400	DO-35	3-63
1N964B-1JAN	13	5	13	9.5	5.0		9.9	+0.079	400	DO-35	3-63
1N964B-1JANTX	13	5	13	9.5	5.0		9.9	+0.079	400	DO-35	3-63
1N964B-1JANTXV	13	5	13	9.5	5.0		9.9	+0.079	400	DO-35	3-63
1N965BJAN	15	5	16	8.5	5.0		11	+0.082	400	DO-35	3-63
1N965BJANTX	15	5	16	8.5	5.0		11	+0.082	400	DO-35	3-63
1N965BJANTXV	15	5	16	8.5	5.0		11	+0.082	400	DO-35	3-63
1N965B-1JAN	15	5	16	8.5	5.0		11	+0.082	400	DO-35	3-63
1N965B-1JANTX	15	5	16	8.5	5.0		11	+0.082	400	DO-35	3-63
1N965B-1JANTXV	15	5	16	8.5	5.0		11	+0.082	400	DO-35	3-63
1N966BJAN	16	5	17	7.8	5.0		12	+0.083	400	DO-35	3-63
1N966BJANTX	16	5	17	7.8	5.0		12	+0.083	400	DO-35	3-63
1N966BJANTXV	16	5	17	7.8	5.0		12	+0.083	400	DO-35	3-63
1N966B-1JAN	16	5	17	7.8	5.0		12	+0.083	400	DO-35	3-63
1N966B-1JANTX	16	5	17	7.8	5.0		12	+0.083	400	DO-35	3-63
1N966B-1JANTXV	16	5	17	7.8	5.0		12	+0.083	400	DO-35	3-63
1N967BJAN	18	5	21	7.0	5.0		14	+0.085	400	DO-35	3-63
1N967BJANTX	18	5	21	7.0	5.0		14	+0.085	400	DO-35	3-63
1N967BJANTXV	18	5	21	7.0	5.0		14	+0.085	400	DO-35	3-63
1N967B-1JAN	18	5	21	7.0	5.0		14	+0.085	400	DO-35	3-63
1N967B-1JANTX	18	5	21	7.0	5.0		14	+0.085	400	DO-35	3-63
1N967B-1JANTXV	18	5	21	7.0	5.0		14	+0.085	400	DO-35	3-63
1N968BJAN	20	5	25	6.2	5.0		15	+0.086	400	DO-35	3-63
1N968BJANTX	20	5	25	6.2	5.0		15	+0.086	400	DO-35	3-63
1N968BJANTXV	20	5	25	6.2	5.0		15	+0.086	400	DO-35	3-63
1N968B-1JAN	20	5	25	6.2	5.0		15	+0.086	400	DO-35	3-63
1N968B-1JANTX	20	5	25	6.2	5.0		15	+0.086	400	DO-35	3-63
1N968B-1JANTXV	20	5	25	6.2	5.0		15	+0.086	400	DO-35	3-63
1N969BJAN	22	5	29	5.6	5.0		17	+0.087	400	DO-35	3-63
1N969BJANTX	22	5	29	5.6	5.0		17	+0.087	400	DO-35	3-63
1N969BJANTXV	22	5	29	5.6	5.0		17	+0.087	400	DO-35	3-63
1N969B-1JAN	22	5	29	5.6	5.0		17	+0.087	400	DO-35	3-63
1N969B-1JANTX	22	5	29	5.6	5.0		17	+0.087	400	DO-35	3-63
1N969B-1JANTXV	22	5	29	5.6	5.0		17	+0.087	400	DO-35	3-63
1N970BJAN	24	5	33	5.2	5.0		18	+0.088	400	DO-35	3-63
1N970BJANTX	24	5	33	5.2	5.0		18	+0.088	400	DO-35	3-63
1N970BJANTXV	24	5	33	5.2	5.0		18	+0.088	400	DO-35	3-63

1

FAIRCHILD DIODES

DIODES

MILITARY QUALIFIED ZENER DIODES
GLASS PACKAGE

DEVICE NO.	V _Z V Nom	Tol. ±V _Z %	Z _Z Ω Max	@I _Z mA	I _R μA Max	@	V _R V	T.C. %/°C Max	P _D mW T _A =25°C	Package No.	Page No.
1N970B-1JAN	24	5	33	5.2	5.0		18	+088	400	DO-35	3-63
1N970B-1JANTX	24	5	33	5.2	5.0		18	+088	400	DO-35	3-63
1N970B-1JANTXV	24	5	33	5.2	5.0		18	+088	400	DO-35	3-63
1N971BJAN	27	5	41	4.6	5.0		21	+090	400	DO-35	3-63
1N971BJANTX	27	5	41	4.6	5.0		21	+090	400	DO-35	3-63
1N971BJANTXV	27	5	41	4.6	5.0		21	+090	400	DO-35	3-63
1N971B-1JAN	27	5	41	4.6	5.0		21	+090	400	DO-35	3-63
1N971B-1JANTX	27	5	41	4.6	5.0		21	+090	400	DO-35	3-63
1N971B-1JANTXV	27	5	41	4.6	5.0		21	+090	400	DO-35	3-63
1N972BJAN	30	5	49	4.2	5.0		23	+091	400	DO-35	3-63
1N972BJANTX	30	5	49	4.2	5.0		23	+091	400	DO-35	3-63
1N972BJANTXV	30	5	49	4.2	5.0		23	+091	400	DO-35	3-63
1N972B-1JAN	30	5	49	4.2	5.0		23	+091	400	DO-35	3-63
1N972B-1JANTX	30	5	49	4.2	5.0		23	+091	400	DO-35	3-63
1N972B-1JANTXV	30	5	49	4.2	5.0		23	+091	400	DO-35	3-63
1N973BJAN	33	5	58	3.8	5.0		25	+092	400	DO-35	3-63
1N973BJANTX	33	5	58	3.8	5.0		25	+092	400	DO-35	3-63
1N973BJANTXV	33	5	58	3.8	5.0		25	+092	400	DO-35	3-63
1N973B-1JAN	33	5	58	3.8	5.0		25	+092	400	DO-35	3-63
1N973B-1JANTX	33	5	58	3.8	5.0		25	+092	400	DO-35	3-63
1N973B-1JANTXV	33	5	58	3.8	5.0		25	+092	400	DO-35	3-63
1N4099JAN	6.8	5	200	0.25	10		5.2	—	250	DO-7	3-70
1N4099JANTX	6.8	5	200	0.25	10		5.2	—	250	DO-7	3-70
1N4099JANTXV	6.8	5	200	0.25	10		5.2	—	250	DO-7	3-70
1N4100JAN	7.5	5	200	0.25	10		5.7	—	250	DO-7	3-70
1N4100JANTX	7.5	5	200	0.25	10		5.7	—	250	DO-7	3-70
1N4100JANTXV	7.5	5	200	0.25	10		5.7	—	250	DO-7	3-70
1N4101JAN	8.2	5	200	0.25	1.0		6.3	—	250	DO-7	3-70
1N4101JANTX	8.2	5	200	0.25	1.0		6.3	—	250	DO-7	3-70
1N4101JANTXV	8.2	5	200	0.25	1.0		6.3	—	250	DO-7	3-70
1N4102JAN	8.7	5	200	0.25	1.0		6.7	—	250	DO-7	3-70
1N4102JANTX	8.7	5	200	0.25	1.0		6.7	—	250	DO-7	3-70
1N4102JANTXV	8.7	5	200	0.25	1.0		6.7	—	250	DO-7	3-70
1N4103JAN	9.1	5	200	0.25	1.0		7.0	—	250	DO-7	3-70
1N4103JANTX	9.1	5	200	0.25	1.0		7.0	—	250	DO-7	3-70
1N4130JANTXV	9.1	5	200	0.25	1.0		7.0	—	250	DO-7	3-70
1N4104JAN	10	5	200	0.25	1.0		7.6	—	250	DO-7	3-70
1N4104JANTX	10	5	200	0.25	1.0		7.6	—	250	DO-7	3-70

FAIRCHILD DIODES

DIODES

MILITARY QUALIFIED ZENER DIODES GLASS PACKAGE

DEVICE NO.	Vz V Nom	Tol. ± Vz %	Zz Ω Max	@Iz mA	Ir μA Max	VR V @	T.C. %/°C Max	Pd mW TA=25°C	Package No.	Page No.
1N4104JANTXV	10	5	200	0.25	1.0	7.6	—	250	DO-7	3-70
1N4105JAN	11	5	200	0.25	0.05	8.5	—	250	DO-7	3-70
1N4105JANTX	11	5	200	0.25	0.05	8.5	—	250	DO-7	3-70
1N4105JANTXV	11	5	200	0.25	0.05	8.5	—	250	DO-7	3-70
1N4106JAN	12	5	200	0.25	0.05	9.2	—	250	DO-7	3-70
1N4106JANTX	12	5	200	0.25	0.05	9.2	—	250	DO-7	3-70
1N4106JANTXV	12	5	200	0.25	0.05	9.2	—	250	DO-7	3-70
1N4107JAN	13	5	200	0.25	0.05	9.9	—	250	DO-7	3-70
1N4107JANTX	13	5	200	0.25	0.05	9.9	—	250	DO-7	3-70
1N4107JANTXV	13	5	200	0.25	0.05	9.9	—	250	DO-7	3-70
1N4108JAN	14	5	200	0.25	0.05	10.7	—	250	DO-7	3-70
1N4108JANTX	14	5	200	0.25	0.05	10.7	—	250	DO-7	3-70
1N4108JANTXV	14	5	200	0.25	0.05	10.7	—	250	DO-7	3-70
1N4109JAN	15	5	100	0.25	0.05	11.4	—	250	DO-7	3-70
1N4109JANTX	15	5	100	0.25	0.05	11.4	—	250	DO-7	3-70
1N4109JANTXV	15	5	100	0.25	0.05	11.4	—	250	DO-7	3-70
1N4110JAN	16	5	100	0.25	0.05	12.2	—	250	DO-7	3-70
1N4110JANTX	16	5	100	0.25	0.05	12.2	—	250	DO-7	3-70
1N4110JANTXV	16	5	100	0.25	0.05	12.2	—	250	DO-7	3-70
1N4111JAN	17	5	100	0.25	0.05	13.0	—	250	DO-7	3-70
1N4111JANTX	17	5	100	0.25	0.05	13.0	—	250	DO-7	3-70
1N4111JANTXV	17	5	100	0.25	0.05	13.0	—	250	DO-7	3-70
1N4112JAN	18	5	100	0.25	0.05	13.7	—	250	DO-7	3-70
1N4112JANTX	18	5	100	0.25	0.05	13.7	—	250	DO-7	3-70
1N4112JANTXV	18	5	100	0.25	0.05	13.7	—	250	DO-7	3-70
1N4113JAN	19	5	150	0.25	0.05	14.5	—	250	DO-7	3-70
1N4113JANTX	19	5	150	0.25	0.05	14.5	—	250	DO-7	3-70
1N4113JANTXV	19	5	150	0.25	0.05	14.5	—	250	DO-7	3-70
1N4114JAN	20	5	150	0.25	0.01	15.2	—	250	DO-7	3-70
1N4114JANTX	20	5	150	0.25	0.01	15.2	—	250	DO-7	3-70
1N4114JANTXV	20	5	150	0.25	0.01	15.2	—	250	DO-7	3-70
1N4115JAN	22	5	150	0.25	0.01	16.8	—	250	DO-7	3-70
1N4115JANTX	22	5	150	0.25	0.01	16.8	—	250	DO-7	3-70
1N4115JANTXV	22	5	150	0.25	0.01	16.8	—	250	DO-7	3-70
1N4116JAN	24	5	150	0.25	0.01	18.3	—	250	DO-7	3-70
1N4116JANTX	24	5	150	0.25	0.01	18.3	—	250	DO-7	3-70
1N4116JANTXV	24	5	150	0.25	0.01	18.3	—	250	DO-7	3-70
1N4117JAN	25	5	150	0.25	0.01	19.0	—	250	DO-7	3-70

FAIRCHILD DIODES

DIODES

MILITARY QUALIFIED ZENER DIODES GLASS PACKAGE

DEVICE NO.	V _Z V Nom	Tol. ± V _Z %	Z _Z Ω Max	@I _Z mA	I _R μA Max	V _R @ V	T.C. %/°C Max	P _D mW T _A =25°C	Package No.	Page No.
1N4117JANTX	25	5	150	0.25	0.01	19.0	—	250	DO-7	3-70
1N4117JANTXV	25	5	150	0.25	0.01	19.0	—	250	DO-7	3-70
1N4118JAN	27	5	150	0.25	0.01	20.5	—	250	DO-7	3-70
1N4118JANTX	27	5	150	0.25	0.01	20.5	—	250	DO-7	3-70
1N4118JANTXV	27	5	150	0.25	0.01	20.5	—	250	DO-7	3-70
1N4119JAN	28	5	200	0.25	0.01	21.3	—	250	DO-7	3-70
1N4119JANTX	28	5	200	0.25	0.01	21.3	—	250	DO-7	3-70
1N4119JANTXV	28	5	200	0.25	0.01	21.3	—	250	DO-7	3-70
1N4120JAN	30	5	200	0.25	0.01	22.8	—	250	DO-7	3-70
1N4120JANTX	30	5	200	0.25	0.01	22.8	—	250	DO-7	3-70
1N4120JANTXV	30	5	200	0.25	0.01	22.8	—	250	DO-7	3-70
1N4121JAN	33	5	200	0.25	0.01	25.1	—	250	DO-7	3-70
1N4121JANTX	33	5	200	0.25	0.01	25.1	—	250	DO-7	3-70
1N4121JANTXV	33	5	200	0.25	0.01	25.1	—	250	DO-7	3-70
1N4620JAN	3.3	5	1650	0.25	7.5	1.5	—	250	DO-7	3-70
1N4620JANTX	3.3	5	1650	0.25	7.5	1.5	—	250	DO-7	3-70
1N4620JANTXV	3.3	5	1650	0.25	7.5	1.5	—	250	DO-7	3-70
1N4621JAN	3.6	5	1700	0.25	7.5	2.0	—	250	DO-7	3-70
1N4621JANTX	3.6	5	1700	0.25	7.5	2.0	—	250	DO-7	3-70
1N4621JANTXV	3.6	5	1700	0.25	7.5	2.0	—	250	DO-7	3-70
1N4622JAN	3.9	5	1650	0.25	5.0	2.0	—	250	DO-7	3-70
1N4622JANX	3.9	5	1650	0.25	5.0	2.0	—	250	DO-7	3-70
1N4622JANTXV	3.9	5	1650	0.25	5.0	2.0	—	250	DO-7	3-70
1N4623JAN	4.3	5	1600	0.25	4.0	2.0	—	250	DO-7	3-70
1N4623JANTX	4.3	5	1600	0.25	4.0	2.0	—	250	DO-7	3-70
1N4623JANTXV	4.3	5	1600	0.25	4.0	2.0	—	250	DO-7	3-70
1N4624JAN	4.7	5	1550	0.25	10	3.0	—	250	DO-7	3-70
1N4624JANTX	4.7	5	1550	0.25	10	3.0	—	250	DO-7	3-70
1N4624JANTXV	4.7	5	1550	0.25	10	3.0	—	250	DO-7	3-70
1N4625JAN	5.1	5	1500	0.25	10	3.0	—	250	DO-7	3-70
1N4625JANTX	5.1	5	1500	0.25	10	3.0	—	250	DO-7	3-70
1N4625JANTXV	5.1	5	1500	0.25	10	3.0	—	250	DO-7	3-70
1N4626JAN	5.6	5	1400	0.25	10	4.0	—	250	DO-7	3-70
1N4626JANTX	5.6	5	1400	0.25	10	4.0	—	250	DO-7	3-70
1N4626JANTXV	5.6	5	1400	0.25	10	4.0	—	250	DO-7	3-70
1N4627JAN	6.2	5	1200	0.25	10	5.0	—	250	DO-7	3-70
1N4627JANTX	6.2	5	1200	0.25	10	5.0	—	250	DO-7	3-70
1N4627JANTXV	6.2	5	1200	0.25	10	5.0	—	250	DO-7	3-70

FAIRCHILD DIODES

DIODES

MATCHED DIODE ASSEMBLIES PLASTIC AND GLASS PACKAGES

Number of Diodes			2	2	4	4	4	
Package			Moulded Pair (308)	Discrete Pair DO-7 or DO-35	Moulded Quad (310)	Discrete Quad DO-7 or DO-35	Moulded Bridge (309)	
V _F Matching (-55°C to +100°C)								
Basic Diode Specification	I _F Range mA	ΔV _F mV	DEVICE NO.	DEVICE NO.	DEVICE NO.	DEVICE NO.	DEVICE NO.	PAGE NO.
1N914	0.01-1.0	3.0	FA2310E	FA2310U	FA4310E	FA4310U	FA3310	3-62
1N3070	0.01-1.0	3.0	FA2320E	FA2320U	FA4320E	FA4320U	FA3320	3-65
1N3595	0.01-1.0	10	FA2330E	FA2330U	FA4330E	FA4330U	FA3330	3-66
—	0.1-10	10	1N4306	—	—	—	—	3-73
—	0.1-10	10	—	—	1N4307	—	—	3-73

MILITARY QUALIFIED DIODE ASSEMBLIES PLASTIC AND GLASS PACKAGES

DEVICE NO.	BV V Min	I _R nA Max	@	V _R V	V _F V Max	@	I _F mA	C pF Max	t _{rr} ns Max	Package No.	Page* No.
1N4306JAN	75	50		50	1.0		50	2.0	4.0	308	3-73
1N4306JANTX	75	50		50	1.0		50	2.0	4.0	308	3-73
1N4306JANTXV	75	50		50	1.0		50	2.0	4.0	308	3-73
1N4307JAN	75	50		50	1.0		50	2.0	4.0	310	3-73
1N4307JANTX	75	50		50	1.0		50	2.0	4.0	310	3-73
1N4307JANTXV	75	50		50	1.0		50	2.0	4.0	310	3-73

*Data sheet is for standard device

MONOLITHIC DIODE ARRAYS (NUMERIC LISTING) PLASTIC - CERAMIC - METAL PACKAGES

DEVICE NO.	BV V Min	V _F V Max	@	I _F mA	ΔV _F mV Max	t _{rr} ns Max	Configuration	Package No.	Page No.
FSA1410M	60	1.0		100	15	10	CA8	TO-96	3-34
FSA1411M	60	1.0		100	15	10	CC8	TO-96	3-34
FSA2002M	60	1.0		100	15	10	CC8	TO-85	3-34
FSA2003M	60	1.0		100	15	10	CA8	TO-85	3-34
FSA2500M	60	1.0		100	15	10	M16	TO-85	3-36
FSA2501M	60	1.0		100	15	10	M16	TO-116-2	3-36
FSA2501P	60	1.0		100	15	10	M16	TO-116	3-36
FSA2502M	60	1.0		100	15	10	M16	TO-96	3-36

FAIRCHILD DIODES

DIODES

MONOLITHIC DIODE ARRAYS (NUMERIC LISTING) PLASTIC - CERAMIC - METAL PACKAGES

DEVICE NO.	BV V Min	V _F V Max	@	I _F mA	ΔV _F mV Max	t _{rr} ns Max	Configuration	Package No.	Page No.
FSA2503M	60	1.0		100	15	10	2M8	TO-116-2	3-39
FSA2503P	60	1.0		100	15	10	2M8	TO-116	3-39
FSA2504M	60	1.0		100	15	10	2M8	TO-86	3-39
FSA2509M	60	1.3		500	15	10	2M8	TO-116-2	3-41
FSA2509P	60	1.3		500	15	10	2M8	TO-116	3-41
FSA2510M	60	1.3		500	15	10	M16	TO-116-2	3-41
FSA2510P	60	1.3		500	15	10	M16	TO-116	3-41
FSA2563M	60	1.3		500	15	10	CC8	TO-116-2	3-43
FSA2563P	60	1.3		500	15	10	CC8	TO-116	3-43
FSA2564M	60	1.3		500	15	10	CA8	TO-116-2	3-43
FSA2564P	60	1.3		500	15	10	CA8	TO-116	3-43
FSA2565M	60	1.3		500	15	10	CC13	TO-116-2	3-43
FSA2565P	60	1.3		500	15	10	CC13	TO-116	3-43
FSA2566M	60	1.3		500	15	10	CA13	TO-116-2	3-43
FSA2566P	60	1.3		500	15	10	CA13	TO-116	3-43
FSA2619M	100	1.0		10	15	5	S8	6B	3-46
FSA2619P	100	1.0		10	15	5	S8	9B	3-46
FSA2620M	100	1.0		10	15	5	S7	TO-116-2	3-46
FSA2620P	100	1.0		10	15	5	S7	TO-116	3-46
FSA2621M	100	1.0		10	15	5	S7	TO-86	3-46
FSA2702M	60	1.0		200	3	6	R4	TO-33	3-49
FSA2703M	60	1.0		200	3	6	R4	TO-72	3-49
FSA2704M	60	1.0		200	—	6	R4	TO-33	3-49
FSA2705M	60	1.0		200	—	6	R4	TO-72	3-49
FSA2719M	75	1.0		10	15	6	S8	6B	3-46
FSA2719P	75	1.0		10	15	6	S8	9B	3-46
FSA2720M	75	1.0		10	15	6	S7	TO-116-2	3-46
FSA2720P	75	1.0		10	15	6	S7	TO-116	3-46
FSA2721M	75	1.0		10	15	6	S7	TO-86	3-46
1N5768	60	1.0		100	—	20	CC8	TO-85	3-81
1N5770	60	1.0		100	—	20	CA8	TO-85	3-81
1N5772	60	1.0		100	—	20	M16	TO-85	3-81
1N5774	60	1.0		100	—	20	2M8	TO-86	3-81
1N6100	75	1.0		100	—	5	S7	TO-86	3-83
1N6101	75	1.0		100	—	5	S7	TO-116-2	3-83

FAIRCHILD DIODES

DIODES

MILITARY QUALIFIED DIODE ARRAYS (NUMERIC LISTING) CERAMIC PACKAGES

DEVICE NO.	BV V Min	V _F V Max	@	I _F mA	t _{fr} ns Max	t _{rr} ns Max	Configuration	Package No.	Page No.
1N5768JAN	60	1.0		100	40	20	CC8	TO-85	3-81
1N5768JANTX	60	1.0		100	40	20	CC8	TO-85	3-81
1N5768JANTXV	60	1.0		100	40	20	CC8	TO-85	3-81
1N5770JAN	60	1.0		100	40	20	CA8	TO-85	3-81
1N5770JANTX	60	1.0		100	40	20	CA8	TO-85	3-81
1N5770JANTXV	60	1.0		100	40	20	CA8	TO-85	3-81
1N5772JAN	60	1.0		100	40	20	M16	TO-85	3-81
1N5772JANTX	60	1.0		100	40	20	M16	TO-85	3-81
1N5772JANTXV	60	1.0		100	40	20	M16	TO-85	3-81
1N5774JAN	60	1.0		100	40	20	2M8	TO-86	3-81
1N5774JANTX	60	1.0		100	40	20	2M8	TO-86	3-81
1N5774JANTXV	60	1.0		100	40	20	2M8	TO-86	3-81
1N6100JAN	75	1.0		100	15	5.0	S7	TO-86	3-83
1N6100JANTX	75	1.0		100	15	5.0	S7	TO-86	3-83
1N6100JANTXV	75	1.0		100	15	5.0	S7	TO-86	3-83
1N6101JAN	75	1.0		100	15	5.0	S7	TO-116-2	3-83
1N6101JANTX	75	1.0		100	15	5.0	S7	TO-116-2	3-83
1N6101JANTXV	75	1.0		100	15	5.0	S7	TO-116-2	3-83

CONFIGURATIONS

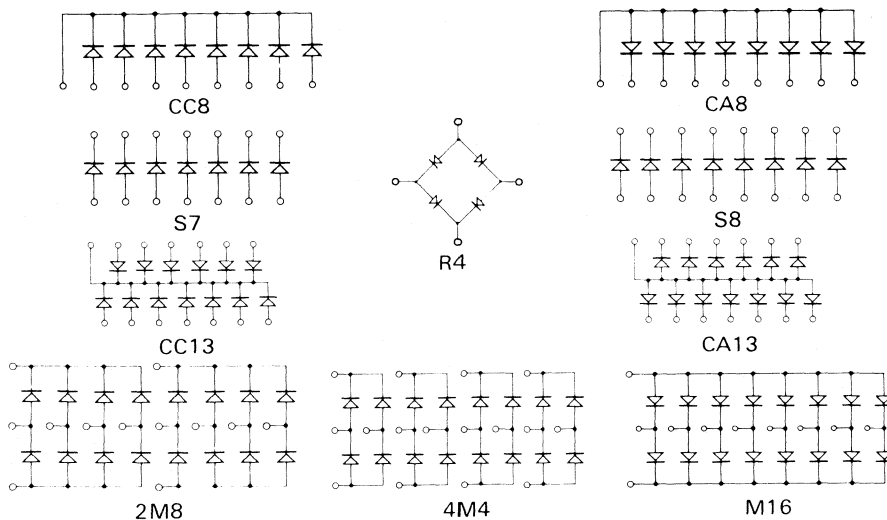

1

FAIRCHILD RECTIFIERS

RECTIFIERS

GENERAL PURPOSE RECTIFIERS GLASS PACKAGE

DEVICE NO.	V _R V Min	@	I _R μA	V _F V Max	@	I _F A	V _{FM} V Max	@	I _O A	Package No.	Page No.
1N4001	50		10	1.1		1.0	1.6		1.0	DO-41	3-68
1N4002	100		10	1.1		1.0	1.6		1.0	DO-41	3-68
1N4003	200		10	1.1		1.0	1.6		1.0	DO-41	3-68
1N4004	400		10	1.1		1.0	1.6		1.0	DO-41	3-68
1N4005	600		10	1.1		1.0	1.6		1.0	DO-41	3-68
1N4006	800		10	1.1		1.0	1.6		1.0	DO-41	3-68
1N4007	1000		10	1.1		1.0	1.6		1.0	DO-41	3-68

FAST RECOVERY RECTIFIERS GLASS PACKAGE

DEVICE NO.	V _R V Min	@	I _R μA Max	V _F V Max	@	I _F A	t _{rr} ns Max	Package No.	Page No.
1N4933	50		5.0	1.2		1.0	200	DO-41	3-77
1N4934	100		5.0	1.2		1.0	200	DO-41	3-77
1N4935	200		5.0	1.2		1.0	200	DO-41	3-77
1N4936	400		5.0	1.2		1.0	200	DO-41	3-77
1N4937	600		5.0	1.2		1.0	200	DO-41	3-77

INDUSTRY / FAIRCHILD CROSS REFERENCE

INDUSTRY DEVICE	NEAREST FAIRCHILD EQUIVALENT	INDUSTRY DEVICE	NEAREST FAIRCHILD EQUIVALENT
AAY11	BA219	BAW55	BAY72
AAY48	BA130	BAW62	1N4448
AAY49	BA129	BAW75	BAW75
AAZ10	BA130	BAW76	BAW76
AAZ13	BA130	BAW77	BAY72
AAZ15	BA219	BAX12	BAY74
AAZ17	BA219	BAX13	BAX13
AAZ18	BA130	BAX15	FDH400
AA112	FDH999	BAX16	BAX16
AA113	BA128	BAX17	FDH400
AA114	BA130	BAX20	FDH444
AA116	BA130	BAX21	FDH444
AA117	BA219	BAX33	FA2310E
AA118	BA219	BAX34	FA2310E
AA129	BA130	BAX35	FA2310E
AA131	FDH900	BAX36	FA2320E
AA132	BA219	BAX37	FA2320E
AA133	BA129	BAX38	FA2320E
AA135	BA129	BAX39	FA4310E
AA136	BA129	BAX40	FA4310E
AA137	BA130	BAX41	FA4310E
AA138	BA130	BAX42	FA4320E
AA139	BA129	BAX43	FA4320E
AA144	BA219	BAX44	FA4320E
BAV17	BAV17	BAX83	BAY72
BAV18	BAV18	BAX84	BAY71
BAV19	BAV19	BAX85	BAY71
BAV20	BAV20	BAX86A	BAY71
BAV21	BAV21	BAX86B	BAY71
BAV24	BAY74	BAX87	BAY71
BAV50	FSA2510M	BAX88	BA129
BAV68	BAY72	BAX89B	BAY71
BAV69	FDH400	BAX89H	BAY71
BAW10	BAY74	BAX90A	BAY71
BAW11	BAY72	BAX90B	BAY71
BAW12	FDH444	BAX91A	BAY71
BAW13	FDH400	BAX91B	BAY71
BAW16	FDH300	BAX91C	BAY71
BAW17	FDH300	BAX92	BAY71
BAW18	FDH300	BAX93	BAY71
BAW24	BAY74	BAX94	BAY71
BAW25	FDH600	BAY17	BAY72
BAW26	FDH600	BAY18	BAY72
BAW33	BAY72	BAY19	BAY72
BAW43	BAY73	BAY20	FDH400
BAW45	BAY71	BAY38	BAY71
BAW46	BAY72	BAY41	BAY71
BAW47	BAY72	BAY42	BAY71
BAW48	BAY71	BAY43	1N4148
BAW49	BAY73	BAY60	BAY74
BAW50	FDH400	BAY61	BAY74
BAW51	BAY72	BAY63	BAY74
BAW52	FDH400	BAY68	BAY74
BAW53	BAY74	BAY69	BAY74
BAW54	BAY74	BAY71	BAY71

1

INDUSTRY / FAIRCHILD CROSS REFERENCE

INDUSTRY DEVICE	NEAREST FAIRCHILD EQUIVALENT	INDUSTRY DEVICE	NEAREST FAIRCHILD EQUIVALENT
BAY72	BAY72	BB122	BB122
BAY73	BAY73	BB139	BB139
BAY74	BAY74	BB141A	BB121A
BAY80	BAY80	BB141B	BB121B
BAY82	BAY82	BB142	BB122
BAY93	BAY71	BB204B	BB204B
BAY94	BAY71	BB204G	BB204G
BAY95	BAY71	BB205A	BB121B
BA127	BA128	BB205B	BB121A
BA128	BA128	BB205G	BB122
BA129	BA129	BB209	BB139
BA130	BA130	BYW37	1N4001
BA136	BA128	BYW38	1N4002
BA152	FDH900	BYW39	1N4003
BA154	FDH900	BYW40	1N4004
BA155	BA129	BYW41	1N4005
BA164	BA164	BYX58 - 100	1N4002
BA165	FDH900	BYX58 - 200	1N4003
BA166	BA130	BYX58 - 300	1N4004
BA167	BA130	BYX58 - 400	1N4004
BA192	FDH400	BYX58 - 50	1N4001
BA193	FDH400	BYX92 - 100	1N4934
BA194	FDH400	BYX92 - 200	1N4935
BA197	FDH400	BYX92 - 50	1N4933
BA198	FDH400	BYX93 - 300	1N4936
BA199 - 250	1N4936	BYX93 - 400	1N4936
BA199 - 350	1N4936	BYY31	1N4003
BA199 - 450	1N4937	BYY32	1N4004
BA199 - 550	1N4937	BYY33	1N4005
BA200	BA218	BYY34	1N4005
BA201	BA219	BY201/2	1N4935
BA202	BA219	BY201/3	1N4936
BA209	BA219	BY201/4	1N4936
BA210	BA219	BY201/6	1N4937
BA211	BA219	BY401	1N4001
BA212	BA219	BY402	1N4002
BA213	BA219	BY403	1N4003
BA214	BA219	BY404	1N4004
BA216	BA216	BZV17	BZX55
BA217	BA217	BZV19	BZX55
BA218	BA218	BZX30	BZX55
BA219	BA219	BZX31	BZX55
BA243	BA243	BZX46	BZX55
BA244	BA244	BZX55	BZX55
BA316	FDH900	BZX58	BZX55
BA317	FDH900	BZX59	BZX55
BA318	FDH900	BZX61	BZX85
BB104B	BB204B	BZX69	BZX55
BB104G	BB204G	BZX71	BZX55
BB105A	BB121B	BZX79	BZX55
BB105B	BB121A	BZX83	BZX55
BB105G	BB122	BZX85	BZX85
BB109	BB139	BZX95	BZX55
BB121A	BB121A	BZX96	BZX55
BB121B	BB121B	BZX97	BZX55

INDUSTRY/FAIRCHILD CROSS REFERENCE

INDUSTRY DEVICE	NEAREST FAIRCHILD EQUIVALENT	INDUSTRY DEVICE	NEAREST FAIRCHILD EQUIVALENT
BZY83	BZX55	FA4330	FA4330
BZY85	BZX55	FA4331	FA4331
BZY88	BZY88	FA4332	FA4332
BZY92	BZX85	FA4333	FA4333
BZY94	BZX55	FA4334	FA4334
DA1701	IN4148	FA4335	FA4335
DA1702	IN4148	FA4360	FA4360
DA1703	IN4148	FA4361	FA4361
DA1704	IN4148	FDH300	FDH300
FA2310	FA2310	FDH333	FDH333
FA2311	FA2311	FDH400	FDH400
FA2312	FA2312	FDH444	FDH444
FA2313	FA2313	FDH600	FDH600
FA2320	FA2320	FDH666	FDH666
FA2321	FA2321	FDH900	FDH900
FA2322	FA2322	FDH999	FDH999
FA2323	FA2323	FDN400	FDH400
FA2324	FA2324	FDN444	FDH444
FA2325	FA2325	FDN600	FDH600
FA2330	FA2330	FDN666	FDH666
FA2331	FA2331	FDN700	FD700
FA2332	FA2332	FDN777	FD777
FA2333	FA2333	FD100	1N4153
FA2334	FA2334	FD300	FDH300
FA2335	FA2335	FD333	FDH333
FA2360	FA2360	FD400	FDH400
FA2361	FA2361	FD444	FDH444
FA3310	FA3310	FD600	FDH600
FA3311	FA3311	FD666	FDH666
FA3312	FA3312	FD700	FD700
FA3313	FA3313	FD777	FD777
FA3320	FA3320	FH1100	FH1100
FA3321	FA3321	FH1200	FH1100
FA3322	FA3322	FJT1100	FJT1100
FA3323	FA3323	FJT1101	FJT1101
FA3324	FA3324	GER4001	1N4001
FA3325	FA3325	GER4002	1N4002
FA3330	FA3330	GER4003	1N4003
FA3331	FA3331	GER4004	1N4004
FA3332	FA3332	GER4005	1N4005
FA3333	FA3333	GER4006	1N4006
FA3334	FA3334	GER4007	1N4007
FA3335	FA3335	MC1103F	FSA2500M
FA3360	FA3360	MC1103L	FSA2501M
FA3361	FA3361	MC1103P	FSA2501
FA4310	FA4310	MC1105F	FSA2002M
FA4311	FA4311	MC1105L	FSA2563M
FA4312	FA4312	MC1105P	FSA2563
FA4313	FA4313	MC1106F	FSA2003M
FA4320	FA4320	MC1106L	FSA2564M
FA4321	FA4321	MC1106P	FSA2564
FA4322	FA4322	MC1107F	FSA2504M
FA4323	FA4323	MC1107L	FSA2503M
FA4324	FA4324	MC1107P	FSA2503
FA4325	FA4325	RF400	RF400

1

INDUSTRY / FAIRCHILD CROSS REFERENCE

INDUSTRY DEVICE	NEAREST FAIRCHILD EQUIVALENT	INDUSTRY DEVICE	NEAREST FAIRCHILD EQUIVALENT
RF401	RF401	1N1044	1N4004
RF500	RF500	1N1045	1N4004
TID121	FSA2563M	1N1046	1N4001
TID122	FSA2563M	1N1047	1N4002
TID123	FSA2564M	1N1048	1N4003
TID124	FSA2564M	1N1049	1N4003
TID125	FSA2510M	1N1050	1N4004
TID126	FSA2510M	1N1051	1N4004
TID131	FSA2504M	1N1052	1N4001
TID132	FSA2504M	1N1053	1N4002
TID133	FSA2509M	1N1054	1N4003
TID134	FSA2509M	1N1055	1N4003
TID135N	FSA2510M	1N1056	1N4004
TID136N	FSA2510M	1N1057	1N4004
TID139F	FSA2721M	1N106	1N4004
TID139N	FSA2720M	1N107	FDH999
TID140F	FSA2721M	1N108	1N4448
TID140N	FSA2720M	1N1081	1N4002
TID21A	FSA2002M	1N1082	1N4003
TID22A	FSA2002M	1N1083	1N4004
TID23A	FSA2003M	1N1083A	1N4004
TID24A	FSA2003M	1N1084	1N4004
TID25A	FSA2500M	1N1084A	1N4004
TID26A	FSA2500M	1N1093	FDH999
1N100	1N4447	1N1095	1N4005
1N100A	1N4448	1N1096	1N4005
1N1005	1N4004	1N1100	1N4002
1N1007	1N4004	1N1101	1N4003
1N1008	1N4004	1N1102	1N4004
1N101	1N3070	1N1103	1N4004
1N1013	1N4004	1N1104	1N4005
1N1016	1N4004	1N1105	1N4005
1N102	1N3070	1N111	1N4148
1N1021	1N4004	1N112	1N4148
1N1022	1N4004	1N1126	1N4004
1N1023	1N4004	1N1127	1N4005
1N1024	1N4004	1N1128	1N4005
1N1028	1N4001	1N113	1N4454
1N1029	1N4002	1N114	1N4454
1N103	1N4448	1N115	1N4454
1N1030	1N4003	1N116	1N4454
1N1031	1N4003	1N116A	1N4454
1N1032	1N4004	1N1169	1N4004
1N1033	1N4004	1N1169A	1N4004
1N1034	1N4001	1N117	1N4454
1N1035	1N4002	1N117A	1N4454
1N1036	1N4003	1N1170	1N4148
1N1037	1N4003	1N118	1N4454
1N1038	1N4004	1N118A	1N4448
1N1039	1N4004	1N119	1N4148
1N104	1N4448	1N120	1N4148
1N1040	1N4001	1N1240	1N4001
1N1041	1N4002	1N1241	1N4002
1N1042	1N4003	1N1242	1N4003
1N1043	1N4003	1N1243	1N4004

INDUSTRY / FAIRCHILD CROSS REFERENCE

INDUSTRY DEVICE	NEAREST FAIRCHILD EQUIVALENT	INDUSTRY DEVICE	NEAREST FAIRCHILD EQUIVALENT
1N1244	1N4004	1N1512	1N4740
1N1244A	1N4004	1N1512A	1N4740A
1N1245	1N4005	1N1513	1N4742
1N1246	1N4005	1N1513A	1N4742A
1N1251	1N4001	1N1514	1N4744
<hr/>			
1N1252	1N4002	1N1514A	1N4744A
1N1253	1N4003	1N1515	1N4746
1N1254	1N4004	1N1515A	1N4746A
1N1255	1N4004	1N1516	1N4748
1N1255A	1N4004	1N1516A	1N4748A
<hr/>			
1N1256	1N4005	1N1517	1N4750
1N1257	1N4005	1N1517A	1N4750A
1N126	1N4148	1N1518	1N4730
1N126A	1N4148	1N1518A	1N4730A
1N127	1N3070	1N1519	1N4732
<hr/>			
1N127A	1N3070	1N1519A	1N4732A
1N128	1N4148	1N152	1N4003
1N128A	1N4148	1N1520	1N4734
1N132	1N4148	1N1520A	1N4734A
1N133	1N4148	1N1521	1N4736
<hr/>			
1N135	1N4148	1N1521A	1N4736A
1N137A	1N483	1N1522	1N4738
1N137B	1N483	1N1522A	1N4738A
1N138A	1N483	1N1523	1N4740
1N138B	1N483	1N1523A	1N4740A
<hr/>			
1N139	1N4148	1N1524	1N4742
1N140	1N4448	1N1524A	1N4742A
1N1406	1N4005	1N1525	1N4744
1N141	1N4148	1N1525A	1N4744A
1N1415	1N4004	1N1526	1N4746
<hr/>			
1N142	1N4938	1N1526	1N4748
1N143	1N4938	1N1526A	1N4746A
1N144	1N4454	1N1527A	1N4748A
1N1440	1N4003	1N1528	1N4750
1N1441	1N4004	1N1528A	1N4750A
<hr/>			
1N1442	1N4004	1N153	1N4004
1N1445	1N4004	1N1551	1N4002
1N145	1N4449	1N1552	1N4003
1N1487	1N4002	1N1553	1N4004
1N1488	1N4003	1N1554	1N4004
<hr/>			
1N1489	1N4004	1N1555	1N4005
1N1490	1N4004	1N1556	1N4002
1N1491	1N4005	1N1557	1N4003
1N1492	1N4005	1N1558	1N4004
1N1507	1N4730	1N1559	1N4004
<hr/>			
1N1507A	1N4730A	1N1560	1N4005
1N1508	1N4732	1N1561	1N4305
1N1508A	1N4732A	1N1562	1N4305
1N1509	1N4734	1N1563	1N4002
1N1509A	1N4734A	1N1564	1N4003
<hr/>			
1N151	1N4002	1N1565	1N4004
1N1510	1N4736	1N1566	1N4004
1N1510A	1N4736A	1N1567	1N4005
1N1511	1N4738	1N1568	1N4005
1N1511A	1N4738A	1N158	1N4004

1

INDUSTRY / FAIRCHILD CROSS REFERENCE

INDUSTRY DEVICE	NEAREST FAIRCHILD EQUIVALENT	INDUSTRY DEVICE	NEAREST FAIRCHILD EQUIVALENT
1N1644	1N4001	1N1776	1N4745
1N1645	1N4002	1N1776A	1N4745A
1N1646	1N4003	1N1777	1N4746
1N1647	1N4003	1N1777A	1N4746A
1N1648	1N4004	1N1778	1N4747
<hr/>			
1N1649	1N4004	1N1778A	1N4747A
1N1650	1N4004	1N1779	1N4748
1N1651	1N4004	1N1779A	1N4748A
1N1652	1N4005	1N1780	1N4749
1N1653	1N4005	1N1780A	1N4749A
<hr/>			
1N1692	1N4002	1N1781	1N4750
1N1693	1N4003	1N1781A	1N4750A
1N1694	1N4004	1N1782	1N4751
1N1695	1N4004	1N1782A	1N4751A
1N1696	1N4005	1N1783	1N4752
<hr/>			
1N1697	1N4005	1N1783A	1N4752A
1N1701	1N4001	1N1875	1N4738
1N1702	1N4002	1N1876	1N4740
1N1703	1N4003	1N1877	1N4742
1N1704	1N4004	1N1878	1N4744
<hr/>			
1N1705	1N4004	1N1879	1N4746
1N1706	1N4005	1N1880	1N4748
1N1707	1N4001	1N1881	1N4750
1N1708	1N4002	1N1882	1N4752
1N1709	1N4003	1N190	FDH999
<hr/>			
1N1710	1N4004	1N1907	1N4001
1N1711	1N4004	1N1908	1N4002
1N1712	1N4005	1N1909	1N4003
1N1744	1N4740	1N191	1N4148
1N175	1N3070	1N1910	1N4004
<hr/>			
1N1763	1N4004	1N1911	1N4004
1N1763A	1N4004	1N1912	1N4005
1N1764	1N4005	1N1913	1N4005
1N1764A	1N4005	1N192	1N4148
1N1765A	1N4734A	1N1927	1N5228A
<hr/>			
1N1766	1N4735	1N1928	1N5230A
1N1766A	1N4735A	1N1929	1N5232A
1N1767	1N4736	1N193	1N4148
1N1767A	1N4736A	1N1930	1N5235A
1N1768	1N4737	1N1931	1N5237A
<hr/>			
1N1768A	1N4737A	1N1932	1N5240A
1N1769	1N4738	1N1933	1N5242A
1N1769A	1N738A	1N1934	1N5245A
1N1770	1N4739	1N1935	1N5248A
1N1770A	1N4739A	1N1936	1N5251A
<hr/>			
1N1771	1N4740	1N194	1N4148
1N1771A	1N4740A	1N194A	1N4148
1N1772	1N4741	1N195	1N4148
1N1772A	1N4741A	1N1954	1N5228A
1N1773	1N4742	1N1955	1N5230A
<hr/>			
1N1773A	1N4742A	1N1956	1N5232A
1N1774	1N4743	1N1957	1N5235A
1N1774A	1N4743A	1N1958	1N5237A
1N1775	1N4744	1N1959	1N5240A
1N1775A	1N4744A	1N196	1N4148

INDUSTRY / FAIRCHILD CROSS REFERENCE

INDUSTRY DEVICE	NEAREST FAIRCHILD EQUIVALENT	INDUSTRY DEVICE	NEAREST FAIRCHILD EQUIVALENT
1N1960	1N5242A	1N2081	1N4002
1N1961	1N5245A	1N2082	1N4003
1N1962	1N5248A	1N2083	1N4004
1N1963	1N5251A	1N2084	1N4004
1N198	1N4148	1N2085	1N4005
1N198A	1N4148	1N2086	1N4005
1N198B	1N4454	1N2088	1N4001
1N198M	1N4148	1N2089	1N4001
1N1981	1N5228A	1N2090	1N4001
1N1982	1N5230A	1N2091	1N4002
1N1983	1N5232A	1N2092	1N4003
1N1984	1N5235A	1N2093	1N4004
1N1985	1N5237A	1N2094	1N4004
1N1986	1N5240A	1N2095	1N4005
1N1987	1N5242A	1N2096	1N4005
1N1988	1N5245A	1N2103	1N4001
1N1989	1N5248A	1N2104	1N4002
1N1990	1N5251A	1N2105	1N4003
1N2013	1N4001	1N2106	1N4004
1N2014	1N4002	1N2107	1N4004
1N2015	1N4003	1N2108	1N4005
1N2016	1N4003	1N2115	1N4004
1N2017	1N4004	1N2116	1N4004
1N2018	1N4004	1N2146	FDH400
1N2019	1N4004	1N2218	1N4005
1N2020	1N4004	1N2220	1N4005
1N2026	1N4001	1N2228	1N4001
1N2027	1N4003	1N2230	1N4003
1N2028	1N4004	1N2232	1N4004
1N2029	1N4004	1N2234	1N4004
1N2030	1N4005	1N2236	1N4005
1N2031	1N4005	1N2238	1N4005
1N2032	1N4732	1N2266	1N4001
1N2033	1N4734	1N2267	1N4001
1N2034	1N4736	1N2268	1N4005
1N2035	1N4739	1N2269	1N4005
1N2036	1N4740	1N2270	1N4005
1N2037	1N4743	1N2271	1N4005
1N2038	1N4745	1N2373	1N4005
1N2039	1N4747	1N2482	1N4003
1N2040	1N4749	1N2483	1N4004
1N2069	1N4003	1N2484	1N4005
1N2069A	1N4003	1N2485	1N4003
1N2070	1N4004	1N2486	1N4004
1N2070A	1N4004	1N2487	1N4004
1N2071	1N4005	1N2488	1N4005
1N2071A	1N4005	1N2489	1N4005
1N2072	1N4001	1N251	1N4148
1N2073	1N4002	1N251A	1N4148
1N2074	1N4003	1N252	1N4148
1N2075	1N4003	1N252A	1N4148
1N2076	1N4004	1N2609	1N4001
1N2077	1N4004	1N2610	1N4002
1N2078	1N4004	1N2611	1N4003
1N2080	1N4001	1N2612	1N4004

1

INDUSTRY / FAIRCHILD CROSS REFERENCE

INDUSTRY DEVICE	NEAREST FAIRCHILD EQUIVALENT	INDUSTRY DEVICE	NEAREST FAIRCHILD EQUIVALENT
1N2613	1N4004	1N301A	1N457
1N2614	1N4005	1N301B	1N457
1N2615	1N4005	1N3016	1N4736
1N2629	1N4305	1N3016A	1N4736A
1N265	1N4148	1N3016B	1N4736B
1N266	1N4148	1N3017	1N4737
1N267	1N4148	1N3017A	1N4737
1N268	1N4148	1N3017B	1N4737A
1N270	FDH444	1N3018	1N4738
1N273	1N4448	1N3018A	1N4738
1N276	1N4454	1N3018B	1N4738A
1N277	1N3070	1N3019	1N4739
1N277M	1N4448	1N3019A	1N4739
1N278	1N4446	1N3019B	1N4739A
1N279	1N4448	1N302	1N4003
1N2791	1N4004	1N302A	1N4003
1N281	1N4448	1N302B	1N4003
1N282	1N4449	1N3020	1N4740
1N283	FDH444	1N3020A	1N4740
1N2858	1N4001	1N3020B	1N4740A
1N2858A	1N4001	1N3021	1N4741
1N2859	1N4002	1N3021A	1N4741
1N2859A	1N4002	1N3021B	1N4741A
1N2860	1N4003	1N3022	1N4742
1N2860A	1N4003	1N3022A	1N4742
1N2861	1N4004	1N3022B	1N4742A
1N2861A	1N4004	1N3023	1N4743
1N2862	1N4004	1N3023A	1N4743
1N2862A	1N4004	1N3023B	1N4743A
1N2863	1N4005	1N3024	1N4744
1N2863A	1N4005	1N3024A	1N4744
1N2864	1N4005	1N3024B	1N4744A
1N2864A	1N4005	1N3025	1N4745
1N287	1N4148	1N3025A	1N4745
1N288	1N4148	1N3025B	1N4745A
1N289	1N4148	1N3026	1N4746
1N290	1N3070	1N3026A	1N4746
1N291	1N3070	1N3026B	1N4746A
1N292	1N4448	1N3027	1N4747
1N294	1N4148	1N3027A	1N4747
1N294A	1N4148	1N3027B	1N4747A
1N295	1N4148	1N3028	1N4748
1N295A	1N4148	1N3028A	1N4748
1N295S	1N4148	1N3028B	1N4748A
1N295X	1N4148	1N3029	1N4749
1N296	1N4148	1N3029A	1N4749
1N297	1N4148	1N3029B	1N4749A
1N297A	1N4148	1N303	1N458
1N298	1N4148	1N303A	1N484B
1N298A	1N4148	1N303B	1N484B
1N299	1N4305	1N3030	1N4750
1N300	1N482B	1N3030A	1N4750
1N300A	1N482B	1N3030B	1N4750A
1N300B	1N482B	1N3031	1N4751
1N301	1N457	1N3031A	1N4751

INDUSTRY / FAIRCHILD CROSS REFERENCE

INDUSTRY DEVICE	NEAREST FAIRCHILD EQUIVALENT	INDUSTRY DEVICE	NEAREST FAIRCHILD EQUIVALENT
1N3031B	1N4751A	1N3179	1N3070
1N3032	1N4752	1N318	1N4003
1N3032A	1N4752	1N318A	1N4003
1N3032B	1N4752A	1N3180	1N3070
1N304	1N4148	1N3181	1N5237A
1N305	1N4607	1N319	1N4004
1N306	1N4607	1N319A	1N4004
1N3062	1N4305	1N3190	1N4004
1N3063	1N4305	1N3191	1N4005
1N3064	1N3064	1N3192	1N4003
1N3065	1N4305	1N3193	1N4003
1N3066	1N4305	1N3194	1N4004
1N3067	1N4148	1N3195	1N4005
1N3068	1N4148	1N3196	1N4005
1N3069	1N4148	1N3197	1N4148
1N307	1N4938	1N320	1N4005
1N3070	1N3070	1N320A	1N4005
1N3071	1N3070	1N3203	1N4305
1N3072	1N4001	1N3204	1N4305
1N3073	1N4002	1N3206	1N4148
1N3074	1N4003	1N3215	1N4152
1N3075	1N4003	1N3223	1N3070
1N3076	1N4004	1N3225	1N4148
1N3077	1N4004	1N3227	1N4002
1N3078	1N4004	1N3228	1N4003
1N3079	1N4004	1N3229	1N4004
1N3080	1N4005	1N323	1N4001
1N3081	1N4005	1N323A	1N4001
1N3082	1N4003	1N3230	1N4005
1N3083	1N4004	1N3237	1N4001
1N3084	1N4005	1N3238	1N4002
1N309	1N4148	1N3239	1N4003
1N3097	1N4305	1N324	1N4002
1N310	1N4148	1N324A	1N4002
1N3110	1N4305	1N3240	1N4004
1N312	1N4448	1N3241	1N4005
1N3121	1N4305	1N3246	1N4001
1N3122	1N4305	1N3247	1N4002
1N3123	1N4305	1N3248	1N4003
1N3124	1N4151	1N3249	1N4004
1N3125	1N4305	1N325	1N4003
1N313	1N4148	1N325A	1N4003
1N314	1N4148	1N3250	1N4005
1N3144	1N4305	1N3253	1N4003
1N3145	1N4305	1N3254	1N4004
1N3146	1N4154	1N3255	1N4005
1N3147	1N4448	1N3257	1N4449
1N315	1N4004	1N3258	1N4448
1N315A	1N4003	1N326	1N4004
1N3159	1N4305	1N326A	1N4004
1N316	1N4001	1N327	1N4005
1N316A	1N4001	1N327A	1N4005
1N3160	1N4305	1N3277	1N4003
1N317	1N4002	1N3278	1N4004
1N317A	1N4002	1N3279	1N4005

1

INDUSTRY / FAIRCHILD CROSS REFERENCE

INDUSTRY DEVICE	NEAREST FAIRCHILD EQUIVALENT	INDUSTRY DEVICE	NEAREST FAIRCHILD EQUIVALENT
1N3298	FDH400	1N355	1N4148
1N3298A	FDH400	1N3550	1N3070
1N330	1N456	1N3559	FDH444
1N331	1N458	1N3564	1N4448
1N332	1N4004	1N3567	1N4448
1N333	1N4004	1N3568	1N4449
1N334	1N4004	1N3575	1N483B
1N335	1N4004	1N3575	1N485B
1N336	1N4003	1N3576	1N484B
1N337	1N4003	1N3578	1N4004
1N338	1N4002	1N3579	1N4004
1N339	1N4002	1N359	1N4001
1N34	1N4454	1N359A	1N4001
1N34A	1N4454	1N3592	1N4305
1N34AS	1N4148	1N3593	1N4148
1N340	1N4002	1N3594	FDH600
1N341	1N4004	1N3595	1N3595
1N342	1N4004	1N3596	1N4449
1N343	1N4004	1N3597	1N3070
1N344	1N4004	1N3598	1N4152
1N345	1N4003	1N3599	1N4938
1N346	1N4003	1N36	1N4148
1N3465	FDH444	1N360	1N4002
1N3466	FDH444	1N360A	1N4002
1N3467	1N4446	1N3600	1N3600
1N3468	1N4446	1N3601	1N4149
1N3469	FDH400	1N3602	1N4151
1N347	1N4002	1N3603	1N4151
1N3470	FDH400	1N3604	1N4151
1N3471	1N4148	1N3605	1N4152
1N3473	1N4003	1N3606	1N4153
1N3474	1N4004	1N3607	1N4151
1N3475	1N4005	1N3608	1N4152
1N3478	1N4003	1N3609	1N4153
1N3479	1N4004	1N361	1N4003
1N348	1N4002	1N361A	1N4003
1N3480	1N4005	1N362	1N4004
1N3483	1N4305	1N362A	1N4004
1N3484	1N4305	1N3625	1N3070
1N3485	1N3070	1N3629	1N4002
1N349	1N4002	1N363	1N4005
1N35	1N4454	1N363A	1N4005
1N350	1N457	1N3630	1N4003
1N351	1N484B	1N3631	1N4004
1N352	1N485B	1N3632	1N4004
1N353	1N4004	1N3633	1N4005
1N3535	1N3070	1N3634	1N4005
1N3536	1N457	1N3639	1N4003
1N354	1N4004	1N3640	1N4004
1N3544	1N4002	1N3641	1N4005
1N3545	1N4003	1N3653	FDH400
1N3546	1N4004	1N3654	1N4448
1N3547	1N4004	1N3656	1N4003
1N3548	1N4005	1N3657	1N4004
1N3549	1N4005	1N3658	1N4005

INDUSTRY / FAIRCHILD CROSS REFERENCE

INDUSTRY DEVICE	NEAREST FAIRCHILD EQUIVALENT	INDUSTRY DEVICE	NEAREST FAIRCHILD EQUIVALENT
1N3666	1N4305	1N3722	1N4148
1N3668	1N4305	1N3728	1N4005
1N3675	1N4736	1N3729	1N4005
1N3675A	1N4736	1N373	1N5227A
1N3675B	1N4736A	1N3731	1N4153
1N3676	1N4737	1N374	1N5229A
1N3676A	1N4737	1N3748	1N4003
1N3676B	1N4737A	1N3749	1N4004
1N3677	1N4738	1N375	1N5230A
1N3677A	1N4738	1N3750	1N4005
1N3677B	1N4738A	1N3753	1N4148
1N3678	1N4739	1N3754	1N4002
1N3678A	1N4739	1N3755	1N4003
1N3678B	1N4739A	1N3756	1N4004
1N3679	1N4740	1N3757	1N4003
1N3679A	1N4740	1N3758	1N4004
1N3679B	1N4740A	1N3759	1N4005
1N368	1N4003	1N376	1N5233A
1N368A	1N4003	1N3769	1N4305
1N3680	1N4741	1N377	1N5236A
1N3680A	1N4741	1N3773	1N4305
1N3680B	1N4741A	1N3777	1N4148
1N3681	1N4742	1N378	1N5238A
1N3681A	1N4742	1N38	1N4148
1N3681B	1N4742A	1N38A	1N3070
1N3682	1N4743	1N38B	1N3070
1N3682A	1N4743	1N3821	1N4728
1N3682B	1N4743A	1N3821A	1N4728A
1N3683	1N4744	1N3822	1N4729
1N3683A	1N4744	1N3822A	1N4729A
1N3683B	1N4744A	1N3823	1N4730
1N3684	1N4745	1N3823A	1N4730A
1N3684A	1N4745	1N3824	1N4731
1N3684B	1N4745A	1N3824A	1N4731A
1N3685	1N4746	1N3825	1N4732
1N3685A	1N4746	1N3825A	1N4732A
1N3685B	1N4746A	1N3826	1N4733
1N3686	1N4747	1N3826A	1N4733A
1N3686A	1N4747	1N3827	1N4734
1N3686B	1N4747A	1N3827A	1N4734A
1N3687	1N4748	1N3828	1N4735
1N3687A	1N4748	1N3828A	1N4735A
1N3687B	1N4748A	1N3829	1N4736
1N3688	1N4749	1N3829A	1N4736A
1N3688A	1N4749	1N3830	1N4737
1N3688B	1N4749A	1N3830A	1N4737A
1N3689	1N4750	1N385	1N4148
1N3689A	1N4750	1N386	1N4148
1N3689B	1N4750A	1N386A	1N458
1N3690	1N4751	1N3865	1N4148
1N3690A	1N4751	1N3866	1N4003
1N3690B	1N4751A	1N3867	1N4004
1N3691	1N4752	1N3868	1N4005
1N3691A	1N4752	1N387	1N4148
1N3691B	1N4752A	1N3872	FDH444

1

INDUSTRY / FAIRCHILD CROSS REFERENCE

INDUSTRY DEVICE	NEAREST FAIRCHILD EQUIVALENT	INDUSTRY DEVICE	NEAREST FAIRCHILD EQUIVALENT
1N3873	FDH444	1N4161	1N4739
1N388	1N4148	1N4161A	1N4739
1N389	1N4148	1N4161B	1N4739A
1N3894	1N4004	1N4162	1N4740
1N3895	1N4004	1N4162A	1N4740
<hr/>			
1N39	1N3070	1N4162B	1N4740A
1N39A	1N3070	1N4163	1N4741
1N39B	1N3070	1N4163A	1N4741
1N390	1N4148	1N4163B	1N4741A
1N391	1N4148	1N4164	1N4742
<hr/>			
1N392	1N4148	1N4164A	1N4742
1N393	1N3070	1N4164B	1N4742A
1N394	1N3070	1N4165	1N4743
1N3943	1N4001	1N4165A	1N4743
1N3944	1N4305	1N4165B	1N4743A
<hr/>			
1N3952	1N3070	1N4166	1N4744
1N3953	1N4148	1N4166A	1N4744
1N3954	1N4150	1N4166B	1N4744A
1N3956	1N4305	1N4167	1N4745
1N3991	1N4305	1N4167A	1N4745
<hr/>			
1N40	1N4148	1N4167B	1N4745A
1N4001	1N4001	1N4168	1N4746
1N4002	1N4002	1N4168A	1N4746
1N4003	1N4003	1N4168B	1N4746A
1N4004	1N4004	1N4169	1N4747
<hr/>			
1N4005	1N4005	1N4169A	1N4747
1N4006	1N4006	1N4169B	1N4747A
1N4007	1N4007	1N417	1N4448
1N4008	1N4305	1N4170	1N4748
1N4009	1N4009	1N4170A	1N4748
<hr/>			
1N4043	1N4154	1N4170B	1N4748A
1N4086	FDH444	1N4171	1N4749
1N4087	FDH900	1N4171A	1N4749
1N4088	1N4148	1N4171B	1N4749A
1N4089	1N4004	1N4172	1N4750
<hr/>			
1N4099-4121	1N4099-4121	1N4172A	1N4750
1N41	1N4454	1N4172B	1N4750A
1N4147	1N914	1N4173	1N4751
1N4148	1N4148	1N4173A	1N4751
1N4149	1N4149	1N4173B	1N4751A
<hr/>			
1N4150	1N4150	1N4174	1N4752
1N4151	1N4151	1N4174A	1N4752
1N4152	1N4152	1N4174B	1N4752A
1N4153	1N4153	1N418	1N4148
1N4154	1N4154	1N419	FDH444
<hr/>			
1N4155	1N4004	1N42	1N3070
1N4158	1N4736	1N4242	FDH900
1N4158A	1N4736	1N4243	FDH900
1N4158B	1N4736A	1N4244	1N4244
1N4159	1N4737	1N4245	1N4003
<hr/>			
1N4159A	1N4737	1N4246	1N4004
1N4159B	1N4737A	1N43	1N4148
1N4160	1N4738	1N4305	1N4305
1N4160A	1N4738	1N4306	1N4306
1N4160B	1N4738A	1N4307	1N4307

INDUSTRY / FAIRCHILD CROSS REFERENCE

INDUSTRY DEVICE	NEAREST FAIRCHILD EQUIVALENT	INDUSTRY DEVICE	NEAREST FAIRCHILD EQUIVALENT
1N4308	1N4150	1N4334B	1N4747A
1N4309	FDH400	1N4335	1N4748
1N431	1N3070	1N4335A	1N4748
1N4310	FDH400	1N4335B	1N4748A
1N4311	1N4607	1N4336	1N4749
<hr/>			
1N4312	FDH444	1N4336A	1N4749
1N4313	1N4151	1N4336B	1N4749A
1N4314	1N4150	1N4337	1N4750
1N4315	FDH400	1N4337A	1N4750
1N4316	FDH400	1N4337B	1N4750A
<hr/>			
1N4317	1N4607	1N4338	1N4751
1N4318	FDH444	1N4338A	1N4751
1N4319	1N4151	1N4338B	1N4751A
1N432	1N4148	1N4339	1N4752
1N432A	1N4446	1N4339A	1N4752
<hr/>			
1N432B	1N4448	1N4339B	1N4752A
1N4322	1N4150	1N434	1N3070
1N4323	1N4736	1N434A	1N3070
1N4323A	1N4736	1N434B	1N3070
1N4323B	1N4736A	1N435	1N4148
<hr/>			
1N4324	1N4737	1N4362	1N484B
1N4324A	1N4737	1N4363	1N3070
1N4324B	1N4737A	1N4373	1N4148
1N4325	1N4738	1N4375	1N4153
1N4325A	1N4738	1N4376	1N4376
<hr/>			
1N4325B	1N4738A	1N4389	1N4148
1N4326	1N4739	1N4390	FD700
1N4326A	1N4739	1N4391	FD700
1N4326B	1N4739A	1N4392	FD700
1N4327	1N4740	1N44	1N3070
<hr/>			
1N4327A	1N4740	1N440	1N4002
1N4327B	1N4740A	1N440B	1N4002
1N4328	1N4741	1N4400	1N4736
1N4328A	1N4741	1N4401	1N4737
1N4328B	1N4741A	1N4402	1N4738
<hr/>			
1N4329	1N4742	1N4403	1N4739
1N4329A	1N4742	1N4404	1N4740
1N4329B	1N4742A	1N4405	1N4741
1N433	1N3070	1N4406	1N4742
1N433A	1N3070	1N4407	1N4743
<hr/>			
1N433B	1N3070	1N4408	1N4744
1N4330	1N4743	1N4409	1N4745
1N4330A	1N4743	1N441	1N4003
1N4330B	1N4743A	1N441B	1N4003
1N4331	1N4744	1N4410	1N4746
<hr/>			
1N4331A	1N4744	1N4411	1N4747
1N4331B	1N4744A	1N4412	1N4748
1N4332	1N4745	1N4413	1N4749
1N4332A	1N4745	1N4414	1N4750
1N4332B	1N4745A	1N4415	1N4751
<hr/>			
1N4333	1N4746	1N4416	1N4752
1N4333A	1N4746	1N442	1N4004
1N4333B	1N4746A	1N442B	1N4004
1N4334	1N4747	1N443	1N4004
1N4334A	1N4747	1N443B	1N4004

1

INDUSTRY / FAIRCHILD CROSS REFERENCE

INDUSTRY DEVICE	NEAREST FAIRCHILD EQUIVALENT	INDUSTRY DEVICE	NEAREST FAIRCHILD EQUIVALENT
1N444	1N4005	1N460B	1N4448
1N444B	1N4005	1N4608	FDH400
1N4442	FDH999	1N461	1N461A
1N4443	1N4148	1N461A	1N461A
1N4444	1N4148	1N4610	1N4150
<hr/>			
1N4445	1N4151	1N462	1N462A
1N4446	1N4446	1N462A	1N462A
1N4447	1N4447	1N4620-4627	1N4620-4627
1N4448	1N4448	1N4628	1N4736A
1N4449	1N4449	1N4629	1N4737A
<hr/>			
1N445	1N4005	1N4628	1N4736A
1N445B	1N4005	1N4629	1N4737A
1N4450	1N4450	1N463	1N463A
1N4451	1N4151	1N463A	1N463A
1N4453	1N4448	1N4630	1N4738A
<hr/>			
1N4454	1N4454	1N4631	1N4739A
1N4455	1N4305	1N4632	1N4740A
1N4456	1N4150	1N4633	1N4741A
1N4457	1N4150	1N4634	1N4742A
1N447	1N4449	1N4635	1N4743A
<hr/>			
1N448	1N4449	1N4636	1N4744A
1N449	1N4151	1N4637	1N4745A
1N45	1N4454	1N4638	1N4746A
1N450	1N4151	1N4639	1N4747A
1N4502	1N4305	1N464	1N463A
<hr/>			
1N451	1N3070	1N464A	1N463A
1N452	1N4448	1N4640	1N4748A
1N4523	1N4305	1N4641	1N4749A
1N4524	1N4305	1N4642	1N4750A
1N453	1N3070	1N4643	1N4751A
<hr/>			
1N4531	1N4148	1N4644	1N4752A
1N4532	FDH600	1N4649	1N4728A
1N4533	1N4152	1N4650	1N4729A
1N4534	1N4153	1N4651	1N4730A
1N4536	1N4154	1N4652	1N4731A
<hr/>			
1N454	FDH444	1N4653	1N4732A
1N4541	1N4004	1N4654	1N4733A
1N4542	1N4004	1N4655	1N4734A
1N4543	1N4005	1N4656	1N4735A
1N4547	1N4151	1N4657	1N4736A
<hr/>			
1N4548	1N4154	1N4658	1N4737A
1N456	1N456	1N4659	1N4738A
1N456A	1N456A	1N4660	1N4739A
1N457	1N457	1N4661	1N4740A
1N457A	1N457A	1N4662	1N4741A
<hr/>			
1N457M	1N457	1N4663	1N4742A
1N458	1N458	1N4664	1N4743A
1N458A	1N458A	1N4665	1N4744A
1N458M	1N458	1N4666	1N4745A
1N459	1N459	1N4667	1N4746A
<hr/>			
1N459A	1N459A	1N4668	1N4747A
1N459M	1N459	1N4669	1N4748A
1N46	1N4454	1N4670	1N4749A
1N460	1N4148	1N4671	1N4750A
1N460A	1N4148	1N4672	1N4751A

INDUSTRY / FAIRCHILD CROSS REFERENCE

INDUSTRY DEVICE	NEAREST FAIRCHILD EQUIVALENT	INDUSTRY DEVICE	NEAREST FAIRCHILD EQUIVALENT
1N4673	1N4752A	1N478	1N4148
1N47	1N3070	1N479	1N4148
1N4728	1N4728	1N48	1N4454
1N4728A	1N4728A	1N480	1N4148
1N4729	1N4729	1N482	1N482B
1N4729A	1N4729A	1N482A	1N482B
1N4730	1N4730	1N482B	1N482B
1N4730A	1N4730A	1N482C	1N482B
1N4731	1N4731	1N4823	1N4002
1N4731A	1N4731A	1N4824	1N4003
1N4732	1N4732	1N4825	1N4004
1N4732A	1N4732A	1N4826	1N4005
1N4733	1N4733	1N4827	1N4448
1N4733A	1N4733A	1N4828	FDH444
1N4734	1N4734	1N4829	FDH444
1N4734A	1N4734A	1N483	1N483B
1N4735	1N4735	1N483A	1N483B
1N4735A	1N4735A	1N483B	1N483B
1N4736	1N4736	1N483C	1N483B
1N4736A	1N4736A	1N4830	FDH444
1N4737	1N4737	1N484	1N484B
1N4737A	1N4737A	1N484A	1N484A
1N4738	1N4738	1N484B	1N484B
1N4738A	1N4738A	1N484C	1N484B
1N4739	1N4739	1N485	1N485B
1N4739A	1N4739A	1N485A	1N485B
1N4740	1N4740	1N485B	1N485B
1N4740A	1N4740A	1N485C	1N485B
1N4741	1N4741	1N486	1N486B
1N4741A	1N4741A	1N486A	1N486B
1N4742	1N4742	1N486B	1N486B
1N4742A	1N4742A	1N4861	1N457
1N4743	1N4743	1N4862	1N457
1N4743A	1N4743A	1N4863	1N4148
1N4744	1N4744	1N4864	1N4151
1N4744A	1N4744A	1N487	1N4004
1N4745	1N4745	1N487A	1N4004
1N4745A	1N4745A	1N487B	1N4004
1N4746	1N4746	1N488	1N4004
1N4746A	1N4746A	1N488A	1N4004
1N4747	1N4747	1N488B	1N4004
1N4747A	1N4747A	1N4888	FD777
1N4748	1N4748	1N49	1N4148
1N4748A	1N4748A	1N490	1N4148
1N4749	1N4749	1N4933	1N4933
1N4749A	1N4749A	1N4934	1N4934
1N4750	1N4750	1N4935	1N4935
1N4750A	1N4750A	1N4936	1N4936
1N4751	1N4751	1N4937	1N4937
1N4751A	1N4751A	1N4938	1N3070
1N4752	1N4752	1N4942	1N4935
1N4752A	1N4752A	1N4943	1N4936
1N476	1N4148	1N4944	1N4936
1N4765	1N4734	1N4945	1N4937
1N477	1N4148	1N4946	1N4937

1

INDUSTRY / FAIRCHILD CROSS REFERENCE

INDUSTRY DEVICE	NEAREST FAIRCHILD EQUIVALENT	INDUSTRY DEVICE	NEAREST FAIRCHILD EQUIVALENT
1N4949	FD700	1N5227	1N5227
1N4950	1N4150	1N5227A	1N5227A
1N4951	1N4607	1N5227B	1N5227B
1N4952	1N4607	1N5228	1N5228
1N4953	FD700	1N5228A	1N5228A
1N497	1N4448	1N5228B	1N5228B
1N498	1N4448	1N5229	1N5229
1N499	1N4448	1N5229A	1N5229A
1N50	1N4148	1N5229B	1N5229B
1N500	1N4448	1N5230	1N5230
1N5004	1N4934	1N5230A	1N5230A
1N5005	1N4935	1N5230B	1N5230B
1N5006	1N4936	1N5231	1N5231
1N5007	1N4937	1N5231A	1N5231A
1N501	1N4448	1N5231B	1N5231B
1N502	1N3070	1N5232	1N5232
1N503	1N4001	1N5232A	1N5232A
1N504	1N4002	1N5232B	1N5232B
1N505	1N4003	1N5233	1N5233
1N5055	1N4934	1N5233A	1N5233A
1N5056	1N4935	1N5233B	1N5233B
1N5057	1N4936	1N5234	1N5234
1N5058	1N4936	1N5234A	1N5234A
1N5059	1N4003	1N5234B	1N5234B
1N506	1N4004	1N5235	1N5235
1N5060	1N4004	1N5235A	1N5235A
1N5061	1N4005	1N5235B	1N5235B
1N507	1N4004	1N5236	1N5236
1N508	1N4005	1N5236A	1N5236A
1N51	1N4454	1N5236B	1N5236B
1N511	1N4001	1N5237	1N5237
1N512	1N4002	1N5237A	1N5237A
1N513	1N4003	1N5237B	1N5237B
1N514	1N4004	1N5238	1N5238
1N515	1N4004	1N5238A	1N5238A
1N516	1N4005	1N5238B	1N5238B
1N5194	1N483B	1N5239	1N5239
1N5195	1N485B	1N5239A	1N5239A
1N5196	1N486B	1N5239B	1N5239B
1N52	1N4454	1N5240	1N5240
1N52A	1N4454	1N5240A	1N5240A
1N520B	1N457	1N5240B	1N5240B
1N5209	1N458	1N5241	1N5241
1N5210	1N459	1N5241A	1N5241A
1N5211	1N4003	1N5241B	1N5241B
1N5212	1N4004	1N5242	1N5242
1N5213	1N4005	1N5242A	1N5242A
1N5215	1N4003	1N5242B	1N5242B
1N5216	1N4004	1N5243	1N5243
1N5217	1N4005	1N5243A	1N5243A
1N5219	FDH900	1N5243B	1N5243B
1N5220	FDH900	1N5244	1N5244
1N5226	1N5226	1N5244A	1N5244A
1N5226A	1N5226A	1N5244B	1N5244B
1N5226B	1N5226B	1N5245	1N5245

INDUSTRY / FAIRCHILD CROSS REFERENCE

INDUSTRY DEVICE	NEAREST FAIRCHILD EQUIVALENT	INDUSTRY DEVICE	NEAREST FAIRCHILD EQUIVALENT
1N5245A	1N5245A	1N539	1N4004
1N5245B	1N5245B	1N54	1N4148
1N5246	1N5246	1N54A	1N4148
1N5246A	1N5246A	1N540	1N4004
1N5246B	1N5246B	1N541	1N4305
<hr/>			
1N5247	1N5247	1N5412	1N4305
1N5247A	1N5247A	1N5413	1N4305
1N5247B	1N5247B	1N5414	1N4305
1N5248	1N5248	1N542	1N4305
1N5248A	1N5248A	1N5427	1N4148
<hr/>			
1N5248B	1N5248B	1N5428	1N3070
1N5249	1N5249	1N5429	1N485
1N5249A	1N5249A	1N5430	1N4150
1N5249B	1N5249B	1N5431	FDH400
1N5250	1N5250	1N5432	FD777
<hr/>			
1N5250A	1N5250A	1N547	1N4005
1N5250B	1N5250B	1N55	1N3070
1N5251	1N5251	1N55A	1N3070
1N5251A	1N5251A	1N55B	1N3070
1N5251B	1N5251B	1N550	1N4002
<hr/>			
1N5252	1N5252	1N551	1N4003
1N5252A	1N5252A	1N552	1N4004
1N5252B	1N5252B	1N553	1N4004
1N5253	1N5253	1N554	1N4005
1N5253A	1N5253A	1N555	1N4005
<hr/>			
1N5253B	1N5253B	1N5559	1N4736
1N5254	1N5254	1N5559A	1N4736
1N5254A	1N5254A	1N5559B	1N4736A
1N5254B	1N5254B	1N5560	1N4737
1N5255	1N5255	1N5660A	1N4737
<hr/>			
1N5255A	1N5255A	1N5560B	1N4737A
1N5255B	1N5255B	1N5561	1N4738
1N5256	1N5256	1N5561A	1N4738
1N5256A	1N5256A	1N5561B	1N4738A
1N5256B	1N5256B	1N5562	1N4739
<hr/>			
1N5257	1N5257	1N5562A	1N4739
1N5257A	1N5257A	1N5562B	1N4739A
1N5257B	1N5257B	1N5563	1N4740
1N527	1N4305	1N5563A	1N4740
1N5282	1N5282	1N5563B	1N4740A
<hr/>			
1N530	1N4002	1N5564	1N4741
1N531	1N4003	1N5564A	1N4741
1N5315	1N4153	1N5564B	1N4741A
1N5316	1N4153	1N5565	1N4742
1N5317	1N4150	1N5565A	1N4742
<hr/>			
1N5318	1N4150	1N5565B	1N4742A
1N5319	1N4305	1N5566	1N4743
1N532	1N4004	1N5566A	1N4743
1N5320	1N4934	1N5566B	1N4743A
1N533	1N4004	1N5567	1N4744
<hr/>			
1N534	1N4005	1N5567A	1N4744
1N535	1N4005	1N5567B	1N4744A
1N536	1N4001	1N5568	1N4745
1N537	1N4002	1N5568A	1N4745
1N538	1N4003	1N5568B	1N4745A

1

INDUSTRY / FAIRCHILD CROSS REFERENCE

INDUSTRY DEVICE	NEAREST FAIRCHILD EQUIVALENT	INDUSTRY DEVICE	NEAREST FAIRCHILD EQUIVALENT
1N5669	1N4746	1N5770	1N5770
1N5669A	1N4746	1N5771	FSA2003M
1N5669B	1N4746A	1N5772	1N5772
1N5570	1N4747	1N5773	FSA2500M
1N5570A	1N4747	1N5774	1N5774
1N5570B	1N4747A	1N5775	FSA2504M
1N5571	1N4748	1N58	1N3070
1N5571A	1N4748	1N58A	1N3070
1N5571B	1N4748A	1N584	1N4004
1N5572	1N4749	1N59	1N4003
1N5572A	1N4749	1N5913	1N4728
1N5572B	1N4749A	1N5913A	1N4728
1N5573	1N4750	1N5913B	1N4728A
1N5573A	1N4750	1N5914	1N4729
1N5573B	1N4750A	1N5914A	1N4729
1N5574	1N4751	1N5914B	1N4729A
1N5574A	1N4751	1N5915	1N4730
1N5574B	1N4751A	1N5915A	1N4730
1N5575	1N4752	1N5915B	1N4730A
1N5575A	1N4752	1N5916	1N4731
1N5575B	1N4752A	1N5916A	1N4731
1N56	1N4148	1N5916B	1N4731A
1N56A	1N4148	1N5917	1N4732
1N5605	1N457	1N5917A	1N4732
1N5606	1N458	1N5917B	1N4732A
1N5607	1N3070	1N5918	1N4733
1N5608	1N3070	1N5918A	1N4733
1N5609	1N3070	1N5918B	1N4733A
1N5614	1N4003	1N5919	1N4734
1N5615	1N4935	1N5919A	1N4734
1N5616	1N4004	1N5919B	1N4734A
1N5617	1N4936	1N5920	1N4735
1N5618	1N4005	1N5920A	1N4735
1N5619	1N4937	1N5920B	1N4735A
1N566	1N3070	1N5921	1N4736
1N567	1N3070	1N5921A	1N4736
1N5679	1N4001	1N5921B	1N4736A
1N568	1N4305	1N5922	1N4737
1N5680	1N4002	1N5922A	1N4737
1N569	1N4305	1N5922B	1N4737A
1N57	1N4454	1N5923	1N4738
1N57A	1N4454	1N5923A	1N4738
1N571	FDH444	1N5923B	1N4738A
1N5711	1N4446	1N5924	1N4739
1N5712	1N4446	1N5924A	1N4739
1N5713	1N4446	1N5924B	1N4739A
1N5719	1N484	1N5925	1N4740
1N5720	1N4448	1N5925A	1N4740
1N5721	1N4448	1N5925B	1N4740A
1N5726	FDH400	1N5926	1N4741
1N5727	FDH400	1N5926A	1N4741
1N5748B	1N5748B	1N5926B	1N4741A
1N5767	1N4448	1N5927	1N4742
1N5768	1N5768	1N5927A	1N4742
1N5769	FSA2002M	1N5927B	1N4742A

INDUSTRY / FAIRCHILD CROSS REFERENCE

INDUSTRY DEVICE	NEAREST FAIRCHILD EQUIVALENT	INDUSTRY DEVICE	NEAREST FAIRCHILD EQUIVALENT
1N5928	1N4743	1N5995A	1N5234A
1N5928A	1N4743	1N5995B	1N5234B
1N5928B	1N4743A	1N5996	1N5235
1N5929	1N4744	1N5996A	1N5235A
1N5929A	1N4744	1N5996B	1N5235B
<hr/>			
1N5929B	1N4744A	1N5997	1N5236
1N5930	1N4745	1N5997A	1N5236A
1N5930A	1N4745	1N5997B	1N5236B
1N5930B	1N4745A	1N5998	1N5237
1N5931	1N4746	1N5998A	1N5237A
<hr/>			
1N5931A	1N4746	1N5998B	1N5237B
1N5931B	1N4746A	1N5999	1N5239
1N5932	1N4747	1N5999A	1N5239A
1N5932A	1N4747	1N5999B	1N5239B
1N5932B	1N4747A	1N60	1N4148
<hr/>			
1N5933	1N4748	1N60A	1N4148
1N5933A	1N4748	1N60C	1N4148
1N5933B	1N4748A	1N60S	1N4148
1N5934	1N4749	1N600	1N4002
1N5934A	1N4749	1N600A	1N4002
<hr/>			
1N5934B	1N4749A	1N6000	1N5240
1N5935	1N4750	1N6000A	1N5240A
1N5935A	1N4750	1N6000B	1N5240B
1N5935B	1N4750A	1N6001	1N5241
1N5936	1N4751	1N6001A	1N5241A
<hr/>			
1N5936A	1N4751	1N6001B	1N5241B
1N5936B	1N4751A	1N6002	1N5242
1N5937	1N4752	1N6002A	1N5242A
1N5937A	1N4752	1N6002B	1N5242B
1N5937B	1N4752A	1N6003	1N5243
<hr/>			
1N596	1N4005	1N6003A	1N5243A
1N5988	1N5226	1N6003B	1N5243B
1N5988A	1N5226A	1N6004	1N5245
1N5988B	1N5226B	1N6004A	1N5245A
1N5989	1N5227	1N6004B	1N5245B
<hr/>			
1N5989A	1N5227A	1N6005	1N5246
1N5989B	1N5227B	1N6005A	1N5246A
1N599	1N4001	1N6005B	1N5246B
1N599A	1N4001	1N6006	1N5248
1N5990	1N5228	1N6006A	1N5248A
<hr/>			
1N5990A	1N5228A	1N6006B	1N5248B
1N5990B	1N5228B	1N6007	1N5250
1N5991	1N5229	1N6007A	1N5250A
1N5991A	1N5229A	1N6007B	1N5250B
1N5991B	1N5229B	1N6008	1N5251
<hr/>			
1N5992	1N5230	1N6008A	1N5251A
1N5992A	1N5230A	1N6008B	1N5251B
1N5992B	1N5230B	1N6009	1N5252
1N5993	1N5231	1N6009A	1N5252A
1N5993A	1N5231A	1N6009B	1N5252B
<hr/>			
1N5993B	1N5231B	1N601	1N4003
1N5994	1N5232	1N601A	1N4003
1N5994A	1N5232A	1N6010	1N5254
1N5994B	1N5232B	1N6010A	1N5254A
1N5995	1N5234	1N6010B	1N5254B

INDUSTRY/FAIRCHILD CROSS REFERENCE

INDUSTRY DEVICE	NEAREST FAIRCHILD EQUIVALENT	INDUSTRY DEVICE	NEAREST FAIRCHILD EQUIVALENT
1N6011	1N5256	1N63	1N4148
1N6011A	1N5256A	1N63A	1N4148
1N6011B	1N5256B	1N631	1N4148
1N6012	1N5257	1N632	1N4148
1N6012A	1N5257A	1N633	1N3070
<hr/>			
1N6012B	1N5257B	1N634	1N3070
1N602	1N4003	1N635	1N3070
1N602A	1N4003	1N636	1N4448
1N603	1N4004	1N64	1N4148
1N603A	1N4004	1N64A	1N4148
<hr/>			
1N604	1N4004	1N643	1N4003
1N604A	1N4004	1N643A	1N4003
1N605	1N4005	1N643M	1N4003
1N605A	1N4005	1N645	1N4004
1N606	1N4005	1N645A	1N4004
<hr/>			
1N606A	1N4005	1N645B	1N4004
1N607	1N4001	1N645J	1N4004
1N607A	1N4001	1N646	1N4004
1N608	1N4002	1N647	1N4005
1N608A	1N4002	1N648	1N4005
<hr/>			
1N609	1N4003	1N65	1N4454
1N609A	1N4003	1N658	1N658
1N6099	1N6099	1N658A	1N658
1N61	1N3070	1N659	1N659
1N610	1N4003	1N659A	1N659
<hr/>			
1N610A	1N4003	1N66	1N4454
1N6100	1N6100	1N66A	1N4454
1N6101	1N6101	1N660	1N660
1N611	1N4004	1N660A	1N660
1N611A	1N4004	1N661	1N661
<hr/>			
1N612	1N4004	1N661A	1N661
1N612A	1N4004	1N664	1N5237A
1N613	1N4005	1N665	1N5242A
1N613A	1N4005	1N666	1N5245B
1N614	1N4005	1N667	1N5248A
<hr/>			
1N614A	1N4005	1N668	1N5251A
1N615	1N4004	1N669	1N5254A
1N616	1N4148	1N67	1N4148
1N617	1N4148	1N67A	1N4148
1N618	1N4148	1N673	1N4004
<hr/>			
1N619	1N4148	1N676	1N4002
1N62	1N3070	1N677	1N4002
1N622	1N4938	1N678	1N4003
1N625	1N625	1N679	1N4003
1N625A	1N4148	1N68	1N3070
<hr/>			
1N625M	1N625	1N68A	1N3070
1N626	1N626	1N681	1N4004
1N626A	1N4148	1N682	1N4004
1N626M	1N626	1N683	1N4004
1N627	1N627	1N684	1N4004
<hr/>			
1N627A	1N3070	1N685	1N4005
1N628	1N628	1N686	1N4005
1N628A	1N3070	1N687	1N4005
1N629	1N629	1N689	1N4005
1N629A	1N3070	1N69	1N4454

INDUSTRY / FAIRCHILD CROSS REFERENCE

INDUSTRY DEVICE	NEAREST FAIRCHILD EQUIVALENT	INDUSTRY DEVICE	NEAREST FAIRCHILD EQUIVALENT
1N69A	1N4454	1N725	1N5256A
1N695	1N4148	1N725A	1N5256B
1N695A	1N4148	1N726	1N5257A
1N696	1N4148	1N726A	1N5257B
1N698	1N4305	1N74	1N4148
<hr/>			
1N699	1N4448	1N746	1N746
1N70	1N3070	1N746A	1N746A
1N70A	1N4148	1N747	1N747
1N702	1N5223A	1N747A	1N747A
1N702A	1N5223B	1N748	1N748
<hr/>			
1N703	1N5227A	1N748A	1N748A
1N703A	1N5227B	1N749	1N749
1N704	1N5229A	1N749A	1N749A
1N704A	1N5229B	1N75	1N3070
1N705	1N5230A	1N750	1N750
<hr/>			
1N705A	1N5230B	1N750A	1N750A
1N706	1N5232A	1N751	1N751
1N706A	1N5232B	1N751A	1N751A
1N707	1N5236A	1N752	1N752
1N707A	1N5236B	1N752A	1N752A
<hr/>			
1N708	1N5232A	1N753	1N753
1N708A	1N5232B	1N753A	1N753A
1N709	1N5234A	1N754	1N754
1N709A	1N5234B	1N754A	1N754A
1N71	FDH900	1N755	1N755
<hr/>			
1N710	1N5235A	1N755A	1N755A
1N710A	1N5235B	1N756	1N756
1N711	1N5236A	1N756A	1N756A
1N711A	1N5236B	1N757	1N757
1N712	1N5237A	1N757A	1N757A
<hr/>			
1N712A	1N5237B	1N758	1N758
1N713	1N5239A	1N758A	1N758A
1N713A	1N5239B	1N759	1N759
1N714	1N5240A	1N759A	1N759A
1N714A	1N5240B	1N761	1N5230A
<hr/>			
1N715	1N5241A	1N762	1N5232B
1N715A	1N5241B	1N763	1N5238B
1N716	1N5242A	1N764	1N5238A
1N716A	1N5242B	1N765	1N5240A
1N717	1N5243A	1N766	1N5243A
<hr/>			
1N717A	1N5243B	1N767	1N5246A
1N718	1N5245A	1N768	1N5249A
1N718A	1N5245B	1N769	1N5252A
1N719	1N5246A	1N770	1N4305
1N719A	1N5246B	1N771	1N4448
<hr/>			
1N720	1N5248A	1N771A	FDH444
1N720A	1N5248B	1N771B	1N4002
1N721	1N5250A	1N772	1N4448
1N721A	1N5250B	1N772A	FDH444
1N722	1N5251A	1N773	1N4448
<hr/>			
1N722A	1N5251B	1N773A	FHD444
1N723	1N5252A	1N774	1N4448
1N723A	1N5252B	1N774A	FDH444
1N724	1N5254A	1N775	1N4448
1N724A	1N5254B	1N776	1N4448

INDUSTRY / FAIRCHILD CROSS REFERENCE

INDUSTRY DEVICE	NEAREST FAIRCHILD EQUIVALENT	INDUSTRY DEVICE	NEAREST FAIRCHILD EQUIVALENT
1N777	1N4448	1N840	FDH444
1N778	1N4148	1N840M	1N3070
1N779	1N3070	1N841	1N3070
1N781	1N4305	1N842	1N3070
1N781A	1N4305	1N843	1N3070
<hr/>			
1N788	1N4448	1N844	1N3070
1N789	1N4148	1N845	1N3070
1N789M	1N4148	1N846	1N4001
1N790	1N4148	1N847	1N4002
1N790M	1N4148	1N848	1N4003
<hr/>			
1N791	1N4448	1N849	1N4004
1N791M	1N4448	1N850	1N4004
1N792	1N4448	1N851	1N4005
1N792M	1N4448	1N852	1N4005
1N793	1N4148	1N857	1N4001
<hr/>			
1N793M	1N4148	1N858	1N4002
1N794	1N4148	1N859	1N4003
1N795	1N4448	1N86	1N4148
1N796	1N4448	1N860	1N4004
1N797	1N3070	1N861	1N4004
<hr/>			
1N798	1N3070	1N862	1N4005
1N799	1N3070	1N863	1N4005
1N800	1N3070	1N868	1N4001
1N801	1N3070	1N869	1N4002
1N802	1N3070	1N87	1N4148
<hr/>			
1N803	1N3070	1N87A	1N4148
1N804	1N3070	1N87S	1N4148
1N805	1N4148	1N87T	1N4148
1N806	1N4148	1N870	1N4003
1N807	1N3070	1N871	1N4004
<hr/>			
1N808	1N4448	1N872	1N4004
1N809	1N3070	1N873	1N4005
1N81	1N4148	1N874	1N4005
1N81A	1N4148	1N879	1N4001
1N810	1N4148	1N88	1N3070
<hr/>			
1N811	1N4148	1N880	1N4002
1N811M	1N4148	1N881	1N4003
1N812	1N4149	1N882	1N4004
1N812M	1N4149	1N883	1N4004
1N813	1N4148	1N884	1N4005
<hr/>			
1N813M	1N4148	1N885	1N4005
1N814	1N4148	1N89	1N4454
1N814M	1N4148	1N890	1N4447
1N815	1N4448	1N891	1N4448
1N815M	1N4448	1N892	1N4448
<hr/>			
1N817	1N3070	1N893	1N3070
1N818	1N4148	1N897	1N4148
1N819	1N4002	1N898	1N4448
1N83	1N4003	1N899	1N3070
1N835	1N4305	1N90	1N4454
<hr/>			
1N837	FDH444	1N900	1N3070
1N837A	FDH444	1N901	1N3070
1N838	1N3070	1N902	1N3070
1N839	1N3070	1N903	1N4148
1N84	1N4148	1N903A	1N4154

INDUSTRY / FAIRCHILD CROSS REFERENCE

INDUSTRY DEVICE	NEAREST FAIRCHILD EQUIVALENT	INDUSTRY DEVICE	NEAREST FAIRCHILD EQUIVALENT
1N903AM	1N4154	1N948	1N4448
1N903M	1N4154	1N949	1N4305
1N904	1N4154	1N95	1N4148
1N904A	1N4154	1N957	1N957
1N904AM	1N4154	1N957A	1N957A
<hr/>			
1N904M	1N4154	1N957B	1N957B
1N905	1N4151	1N958	1N958
1N905A	1N4154	1N958A	1N958A
1N905AM	1N4154	1N958B	1N958B
1N905M	1N4154	1N959	1N959
<hr/>			
1N906	1N4149	1N959A	1N959A
1N906A	1N4447	1N959B	1N959B
1N906AM	1N4447	1N96	1N4447
1N906M	1N4447	1N96A	1N4148
1N907	1N4149	1N960	1N960
<hr/>			
1N907A	1N4448	1N960A	1N960A
1N907AM	1N4447	1N960B	1N960B
1N907M	1N4149	1N961	1N961
1N908	1N4149	1N961A	1N961A
1N908A	1N4447	1N961B	1N961B
<hr/>			
1N908AM	1N4447	1N962	1N962
1N908M	1N4149	1N962A	1N962A
1N909	1N4449	1N962B	1N962B
1N91	1N4002	1N963	1N963
1N910	1N4449	1N963A	1N963A
<hr/>			
1N911	1N4449	1N963B	1N963B
1N914	1N914	1N964	1N964
1N914A	1N914A	1N964A	1N964A
1N914B	1N914B	1N964B	1N964B
1N914M	1N914	1N965	1N965
<hr/>			
1N915	1N914B	1N965A	1N965A
1N916	1N916	1N965B	1N965B
1N916A	1N916A	1N966	1N966
1N916B	1N916B	1N966A	1N966A
1N917	1N914	1N966B	1N966B
<hr/>			
1N919	1N3070	1N967	1N967
1N92	1N4003	1N967A	1N967A
1N920	FDH400	1N967B	1N967B
1N921	FDH400	1N968	1N968
1N922	FDH400	1N968A	1N968A
<hr/>			
1N923	FDH400	1N968B	1N968B
1N924	1N483	1N969	1N969
1N925	1N4148	1N969A	1N969A
1N926	1N4148	1N969B	1N969B
1N927	1N4148	1N97	1N4148
<hr/>			
1N928	1N3070	1N97A	1N4447
1N929	1N4446	1N970	1N970
1N93	1N4004	1N970A	1N970A
1N930	1N4446	1N970B	1N970B
1N931	1N3070	1N971	1N971
<hr/>			
1N932	1N3070	1N971A	1N971A
1N933	1N3070	1N971B	1N971B
1N934	1N3070	1N972	1N972
1N94	1N4004	1N972A	1N972A
1N947	1N4005	1N972B	1N972B

1

INDUSTRY/FAIRCHILD CROSS REFERENCE

INDUSTRY DEVICE	NEAREST FAIRCHILD EQUIVALENT	INDUSTRY DEVICE	NEAREST FAIRCHILD EQUIVALENT
1N973	1N973	1N997	1N4148
1N973A	1N973A	1N998	1N484B
1N973B	1N973B	1N999	1N914
1N98	1N4454	1S44	1S44
1N98A	1N4448	1S920	1S920
<hr/>		<hr/>	
1N99	1N4148	1S921	1S921
1N99A	1N4454	1S922	1S922
1N993	1N4447	1S923	1S923
1N994	1N4151		
1N995	1N4305		

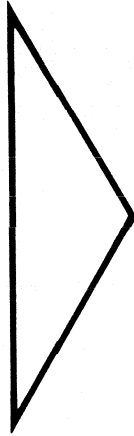
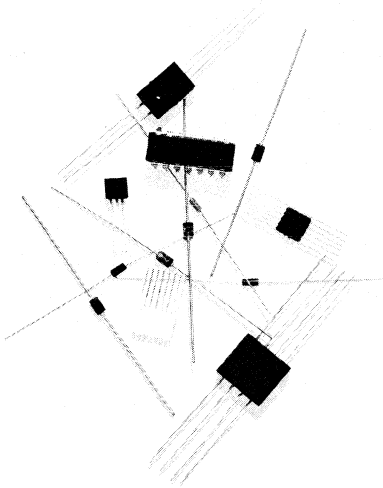

DEVICE SELECTION GUIDES 1

RELIABILITY 2

PRODUCT INFORMATION 3

FAMILY CURVES 4

GLOSSARY OF SYMBOLS AND TERMS 5

FAIRCHILD FIELD SALES OFFICES,
SALES REPRESENTATIVES AND
DISTRIBUTOR LOCATIONS 6

Reliability

INTRODUCTION

Device reliability is becoming increasingly important as systems are made bigger and more complex than ever before. Unfortunately, as systems grow, so does the cost of device failures. The failure of a single component can easily cause thousands of times its value in downtime and repair costs. For a company to receive and use even one unreliable lot of components usually results in large financial losses and an undesirable reputation.

The demands for consistently good reliability in high-volume, low-cost products is increasing. Since low cost precludes the use of special screening or preconditioning, this increase must be obtained through design and process improvements and more secure controls.

Fairchild has installed major systems to insure consistently good reliability.

The manufacture of semiconductor devices involves a series of complex processing steps requiring the use of state-of-the-art fabrication techniques and carefully selected controls to insure consistent product reliability. These techniques include diffusion, which requires high temperatures and controlled doping levels; oxidation, which requires the same high temperatures; passivation deposition, which requires precise flow rates and temperatures; metallization, which requires vacuum evaporation and electroplating; and die separation, which requires the careful use of either saw or laser scribing. All of these processes require a system of controls to maintain reproducibility, which is the key to device reliability.

DESIGNED-IN RELIABILITY

Because of the complex processing involved in the manufacture of semiconductors, two basic ingredients are required to consistently generate a reliable product. First, the device must be designed with the latest technology, which enhances reliability, making use of the best available geometric design, state-of-the-art passivation and metallization systems and proven packaging techniques and materials. Then reliability must be *built* into the device with carefully controlled manufacturing practices utilizing the most up-to-date processing techniques and highly trained personnel. Both are essential because neither will assure reliability alone. A properly designed device will be reliable if it is manufactured as designed.

The reliability of some semiconductor devices can sometimes be impaired greatly by only slight variations in processing, materials or techniques. These variations can, for example, be in water or chemical purity, the temperature or humidity in the fabrication or assembly area, the impurity content of piece parts, or variation in an operator's training or frame of mind. It is Fairchild's belief that small processing variations like these should have little influence on the device's reliability. To this end we continue to develop new design innovations where small processing variations will have no effect on the high reliability that was designed-in.

Silicon Nitride

In 1968 silicon nitride was introduced on Fairchild diodes as an additional passivation. Since then, over 650 million device hours of testing have proven it to be more than three times as reliable than thermally grown silicon dioxide. This is because silicon nitride is an almost impenetrable barrier to the abundant alkali earth elements, especially sodium. The presence of these mobile positive ions in a passivation layer will cause high surface fields which can lead to a device degradation or complete failure.

This improvement in life test performance is attributed to the density of silicon nitride which prevents the migration of mobile ion contaminants under the influence of a reverse bias. A thin layer of the nitride is deposited over a thermally grown silicon dioxide layer, and in turn, is covered by a layer of deposited oxide. The nitride is dense enough to block the migration of such contaminants as lithium, sodium and potassium, which are the major causes of long-term failures, affecting junction leakage, mobility, and breakdown voltage, leading to device degradation.

Thermally grown *silicon dioxide*, which is still the industry standard surface passivation, is highly susceptible to infiltration of these elements. If, however, the oxide is covered with silicon nitride early in the fabrication process, it will be protected through the subsequent operations--even the high temperature DO-35 sealing process.

Channel Stop

In the event that an inversion layer should be formed in the area not protected by nitride, the diffused channel stop prevents any corresponding current flow. Because it is of a higher concentration, its surface will not allow inversion layer formation. This provides for long-term stability of the diode's reverse electrical characteristics.

Deposited Oxide

The deposited oxide layer provides scratch protection during final fabrication and increases the thickness of the dielectric passivation on the surface of the chip. This increase in thickness reduces the electric field strength through the passivation, eliminating dielectric breakdown and arc-over under reverse bias. Other added benefits include a reduction in the driving force for ion migration and a reduction of parasitic capacitance.

Epitaxial Construction

Epitaxial construction allows the device to be manufactured with more uniform reverse breakdown and forward voltage drop characteristics. This results in reproducible electrical characteristics with higher forward current capability and lower power loss. In particular, the breakdown characteristic is improved by utilizing a combination of avalanche and reach-through breakdowns. The junction is diffused far enough into the chip to provide the necessary avalanche breakdown which is dependent on the junction characteristics, while the depletion region is "reaching through the higher resistivity epitaxy to the lower resistivity base" under reverse voltage application. Therefore, if the junction is diffused so that avalanche breakdown takes place just after reach-through is achieved, sharp knees and low leakage near breakdown are observed.

Metallization

Fairchild has chosen a particular combination of metals to provide protection against undesirable intermigration, provide high conductivity, and to provide a dynamic range for temperature cycling.

Metallurgical Bond

Fairchild's Diode Division has developed an improved die in the now widely accepted DO-35 package and has now over four years of successful production experience with the new diode.

The improvements allow the die to dissipate more power, withstand higher pulse amplitudes and to have superior mechanical characteristics when compared to the conventional switching diodes.

Additional benefits of the metallurgically bonded diode are lower failure rates due to open or intermittent circuit that might be caused by lead insertion, or operation over a wide range of environmental temperatures.

The Fairchild Diode Reliability Engineering Department has monitored the reliability of this product on environmental and life test for over four years. It has consistently obtained reliability results that represent more than a five-fold improvement over conventional diodes.

RELIABILITY CONTROL

Although design functions can increase the inherent reliability of semiconductors, there is no doubt that the extent of process variation must be defined and controlled in order to insure that the design functions are effective. In order to achieve this control, and to insure reproducibility in production, Fairchild has instituted a system of controls designed to monitor process variance and reliability.

Visual Inspection

The first and oldest reliability monitor is a series of visual inspections incorporated after critical processing steps. The inspection station is under the joint jurisdiction of the Reliability and Quality Assurance groups, in order to keep close control over visual quality, which is related to reliability. All material intended for shipment to the customer must pass visual inspection gates included in the process flow. The acceptance criteria are defined in standardized reliability specifications so each and every run is inspected in the same way. The standardized inspections keep the process variation in control, thus producing reliable finished devices.

Visual inspections are incorporated throughout the manufacturing process from receiving inspection to wafer and die fabrication, through sealing, and as part of the final Quality Assurance inspection as standard practice. Up to eighteen inspections are performed between receiving inspection and finished device shipment.

Process and Procedure Monitors

The second part of the control program is a set of process and procedure monitors which are direct measures of process and procedure variation. As a procedural control, a process auditor reviews each operation at least once every six months. This is achieved by watching the operation and matching all steps to the current revision of the process specification which is kept on file in the reliability area.

Immediately upon completion of the audit, a summary is distributed to the area supervisor and the responsible process and reliability engineers and department heads. Corrective action and re-audit is then performed, on any variation found.

Process monitors have been instituted at key points in the fabrication flow to give a quantitative basis for process control. These include a visual inspection and measurement of scribe width, depth and orientation immediately after wafer scribe to correlate scribing to break-up quality, thickness and density measurements of deposited passivation layers including nitride and oxide; a cross-check of metal thickness and content; and measurement of C/V at all oxidation furnaces.

Electrical Classification Monitor

The third control is an electrical monitor. A sample of each and every lot of dice is assembled under controlled conditions and is then classified electrically for all D.C. parameters. The results of the electrical classification are compared to established accept/reject criteria.

This electrical inspection is as important as the previously mentioned visual inspection gates. Substandard lots are not allowed to be shipped to customers. Lots that perform better than norm are reviewed and analysed. The results are fed back to Engineering for their product improvement programs.

On a periodic basis, the electrical classification accept/reject criteria are upgraded to take into effect product improvements and reliability.

Reliability Assurance Monitor (RAM)

Although proper design and process monitors provide the basis for the manufacture of reliable semiconductor devices, the true measure of performance is in use. At Fairchild, an extensive life test program provides direct feedback to the production line for the purposes of defining the limits of process variance and design change.

The Reliability Assurance Monitor (RAM) was instituted in 1972 as a program designed to life test samples of each and every lot of die intended for shipment to the customer. This program generates reliability information on all diode types, as well as historical information which is useful in evaluating the effects of design changes and process optimization. All tests are performed at an accelerated rate so that the failure rates on test are much higher than those experienced in the field. In addition to being a monitor, the RAM program is used as a stop point for die lots which fail according to established accept/reject criteria.

The following is a summary of life tests currently performed on RAM. Included are the purposes, description, and defect modes disclosed on each test.

High Temperature Reverse Bias (HTRB)

HTRB testing is performed on all devices requiring reverse bias capabilities in use, or those devices on which the passivation quality is of importance. The on-test voltage ranges from 2V to 150V at 150°C. The expected mode of failure is channeling or polarized surface contamination which are recoverable with baking or cleaning.

Alternating Current Operating Life (ACOL)

ACOL testing is performed on all products intended for use in both the forward and reverse modes. This includes switching diodes and consumer devices used in protection circuits. ACOL is the most accurate measure of reliability in the field for these devices since it tests reverse voltage blocking capabilities under power. The forward current ranges from 50mA to 200mA while the reverse voltage ranges from 10V to 150V being switched between these extremes at 60Hz. ACOL failures are similar to those found in the field and include contact failures (leading to high voltage drops) and chip integrity failures (which are formed with heat and reverse bias). These failures are usually not recoverable.

Direct Current Operating Life (DCOL)

DCOL testing is performed on all devices as a check for contact abnormalities or to monitor the chip-package combination power rating. DCOL is intended for devices which will see forward current application and for those alloy-type devices where contact is critical. The failures generated include chip integrity (coefficient of expansion matching) and some surface-generated failures, as in HTRB. Failures may be recoverable, depending on which mode is observed. Zener diodes are operated over the breakdown knee at the specified power rating whereas all other devices are tested in the forward mode. Test currents range from 50mA to 400mA for all non-zener type devices.

Temperature Cycling and Thermal Shock (TcTs)

TcTs are tests performed on all devices and are designed to examine package/chip integrity and to confirm the validity of failures on other tests. Basically these tests are intended to evaluate materials' integrity. Usually the failures result in fractured dice, so recovery is not normally possible.

Zener Operating Life (ZOPL)

On zener operating life, zener devices are operated with constant reverse bias at maximum rated power. This is a test of the power and voltage handling capabilities of the device and is the only life test commonly run on zeners.

Qualification Program

Special Test and Internal Qualification testing is a program designed to test prototype devices under design or process change, or to internally qualify new products. Tests performed depend on the type of device being tested, but most often RAM life testing conditions are used and some military type environmental tests are included. The RAM criteria are used for history matching and control units are placed on test alongside test units as an added check to test validity. Several production runs are included to provide a reasonable cross-section of device characteristics. Once the testing has been satisfactorily completed, the data is reviewed by Reliability and Engineering. Upon approval of the design by both Fairchild and the customer, the production line is then fully converted to incorporate the product or process change.

With this level of device testing and characterization, the incorporation of new processes, designs and products can be fully evaluated prior to marketing. It is essential to fully evaluate changes in this way in order to insure that reliability does not suffer. New limits of process variation can be defined and a history of device behavior can be obtained before line changeover so that any reliability problems are well known before the product is shipped to the customer.

Failure Analyses

Fairchild's Diode Division has a complete analysis laboratory with state-of-the-art equipment and the lab is staffed by fulltime specialists and engineering support technicians. In addition, ready support from the corporate R&D facility is available for in-depth studies using SEM, multiple beam interferometry and Auger analysis.

It is the policy of Fairchild to perform failure analysis of defective product and utilize the findings resulting from these analyses to improve product integrity and reliability.

Reliability Engineering Feedback

The data from all of these monitors, programs and inspections are reduced and plotted on control charts which are posted in the appropriate areas. In this way data can be provided to the Engineering Department as an aid in correcting any process variations, should they occur.

This combination of Reliability examinations provides a continuing check on how critical processes are functioning and on how these functions are being accomplished. It allows not only the operations, but also the operators to be controlled.

RELIABILITY DATA

In this section is presented the data which has been generated as a result of Fairchild's continuing reliability testing programs. This data is a summation of the results of testing performed since 1971. The devices used had no special screening or preconditioning and were selected from the middle of each respective electrical distribution. All test methods of standard diodes were to MIL-STD-750.

For each product family, Operating Life test data and High Temperature Reverse Bias (HTRB) test data has been plotted and extrapolation is tangential from the last data point in each case. This gives the "worst-case" conditions provided no new failure modes or mechanisms are generated within that time period. Given the design of the devices, the results of a small number of 10,000 hour life tests, and the possible failure mechanisms, the probability of the generation of a new failure mode within 100,000 hours is very small. On the 10,000 hour tests conducted (which are too few in number to provide a statistically significant sample) no new failure modes were found and the failure rates were lower at 10,000 hours than would have been predicted from the extrapolated data.

These graphs, when used as described later (see "In-Use Reliability") should provide the information necessary to predict the reliability of the various Fairchild diode products in a system application.

PRODUCT FAMILY - FDH4

The FDH4 family of diodes are general purpose switching diodes in the DO-35 package. This family includes the FDH400, FDH444, 1N3070, 1N658, 1N663 and many others. These diodes couple fast switching speed with high forward conduction and high blocking voltages

TEST DESCRIPTION	LENGTH OF TEST	OBSERVED FAILURE RATE
Temperature Cycling Method 1051, Cond C	10 Cycles	0.11%
Thermal Shock Method 1056, Cond. A	10 Cycles	0.0%
Moisture Resistance Method 1021	10 Days	0.0%
Shock 1,500G, T=0.5 ms, Method 2016	5 Blows	0.0%
Vibration Fatigue 20G, Method 2046	96 Hours	0.0%
Vibration Variable Frequency 20G (pk) Method 2056	48 Minutes	0.0%
Constant Acceleration 20,000G (pk) Method 2006	3 Minutes	0.0%
Lead Fatigue, 1 pound three 90° arcs Method 2036, Cond. E	6 Seconds	0.0%
Salt Atmosphere, Method 1041	24 Hours	0.0%
Surge Current, I _o = 10 mA I _f (surge) = 500 mA (pk) 100°C t _p = 1/120 s V _R = 175 V (pk)	10 Surges	0.0%
Surge Current, I _F = 100 mA I _F (surge) = 500 mA (pk) t _p = 1 s	fs-110 Surges	0.0%
Surge Current I _F = 100 mA I _f (surge) = 2.0 A (pk) t _p = 1 μs., Method 4066	10 Surges	0.0%
High Temperature Storage 200°C	1000 Hours	0.1%
AC Operating Life, I _O = 200 mA, V _R = 150 V, T _A = 25°C	0-168 Hours	0.8%
	168-1000 Hours	0.5%
High Temperature Reverse Bias, T _A = 150°C	0-168 Hours	1.9%
VR = 150 V	168-1000 Hours	0.14%

2

FAILURE DEFINITION:

Breakdown Voltage

IR = 5 μA
BV < 200 V

Reverse Current

VR = 150 V
IR > 200 nA

Forward Voltage

IF 200 mA
VF < 1.0 V

Capacitance

VR = 0 V
C > 5.0 pF

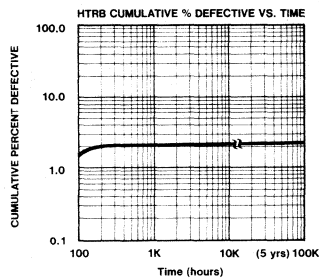
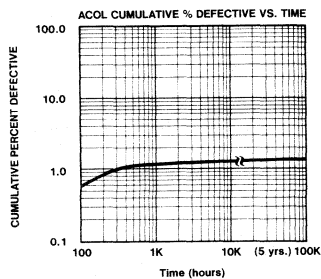

PRODUCT FAMILIES FD5 AND FDH5

The FD5 and FDH5 families are general purpose, low leakage diodes in the DO-7 and DO-35 packages. These families include the 1N3595, 1N486B, 1N459, FDH300 and many others. These diodes couple very low reverse leakage current with high forward conduction and high reverse blocking voltage.

TEST DESCRIPTION	LENGTH OF TEST	OBSERVED FAILURE RATE
Temperature Cycling Method 1051, Cond. C	10 Cycles	0.23%
Thermal Shock Method 1056 Cond. A	10 Cycles	0.0%
Moisture Resistance Method 1021	10 Days	0.0%
Shock 1500G t = 0.5 ms, Method 2016	5 Blows	0.0%
Vibration Variable Frequency 20G (pk) Method 2056	48 Minutes	0.0%
Vibration Variable Frequency Monitored 20G (pk) Vr = 100 V, Method 2057	24 Minutes	0.0%
Vibration Fatigue 20G (pk), Method 2046	96 Hours	0.0%
Constant Acceleration 20KG (pk) Method 2006	3 Minutes	0.0%
Lead Fatigue 1 pound three 90°C arcs Method 2036, Cond. E	6 Seconds	0.0%
Salt Atmosphere, Method 1041	24 Hours	0.07%
Surge Current Io = 200 mA IF (surge) = 2.0 A (pk) tp = 1/120 s	10 Surges	0.0%
Surge Current Io = 150 mA IF (surge) = 500 mA (pk) tp = 1 s, Method 4066	10 Surges	0.0%
High Temperature Storage, 200°C	1000 Hours	0.27%
AC Operating Life; IO = 200 mA VR = 125 V TA = 25°C	0-168 Hours	0.44%
	168-1000 Hours	0.17%
High Temperature Reverse Bias; TA = 150°C VR = 125 V	0-168 Hours	0.66%
	168-1000 Hours	0.36%

FAILURE DEFINITION:

Breakdown Voltage

IR = 5 μ A
BV < 200 V

Reverse Current

VR = 125 V
IR > 2.0 nA

Forward Voltage

IF = 200 mA
VF > 1.0 V

Capacitance

VR = 0V
C > 8.0 pF

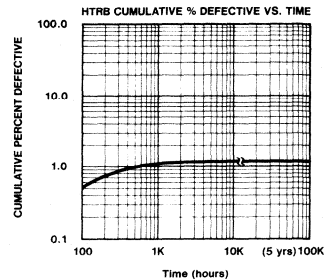
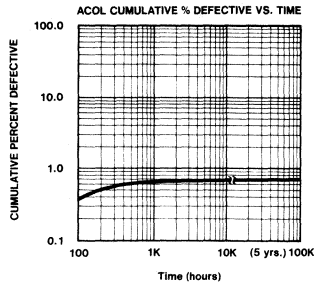

PRODUCT FAMILY FDH-6 METALLURGICAL BONDED

The FDH-6 family of diodes is composed of fast switching diodes in the DO-35 package. This family includes the JAN1N4148-1, JAN1N4454-1, FDH-600, FDH-666 and many others. These diodes couple extremely fast switching speed and high forward conductance with a miniature package which makes them desirable also as general purpose diodes.

TEST DESCRIPTION	LENGTH OF TEST	OBSERVED FAILURE RATE
Temperature Cycling Method 1051, Cond. C	10 Cycles	0.10%
Thermal Shock Method 1056, Cond. A	10 Cycles	0.0%
Moisture Resistance Method 1021	10 Days	0.0%
Shock 1,500G 5 blows t = 0.5 mSec, Method 2016		0.0%
Vibration Variable Frequency 30G (pk) Method 2056	48 Minutes	0.0%
Constant Acceleration 20,000G (pk) Method 2006	3 Minutes	0.0%
Lead Fatigue Method 2036, Cond. E	6 Seconds	0.0%
Salt Atmosphere, Method 1041	24 Hours	0.0%
Surge Current IF = 200 mA if (surge) = 500 mA (pk) tp = 1/120 s	10 Surges	0.0%
Surge Current IF = 200 mA if (surge) = 4.0 A (pk) tp = 1 second	10 Surges	0.0%
Surge Current IF = 50 mA if (surge) = 2.0 A (pk) tp = 1μs Method 4066	10 Surges	0.0%
VF pull IF = 200 mA, 10 lbs.	15 Seconds	0.4%
High Temperature Storage 200°C	1000 Hours	0.09%
AC Operating Life IO = 200 mA	0-168 Hours	0.38%
VR = 50 V, TA = 25°C	168-1000 Hours	0.11%
High Temperature Reverse Bias	0-168 Hours	0.27%
TA = 150°C, VR = 50 V	168-1000 Hours	0.10%

2

FAILURE DEFINITION:

Breakdown Voltage

IR = 5 μA
BV > 75 V

Reverse Current

VR = 50 V
IR < 200 nA

Forward Voltage

IF = 200 mA
VF < 1.0 V

Capacitance

VR = 0V
C > 2.0 pF

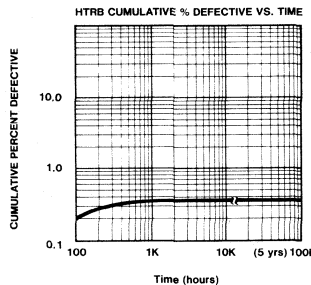
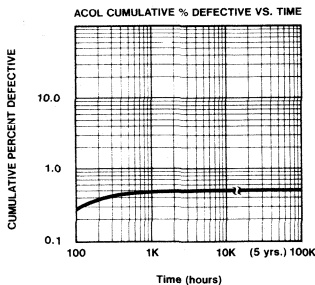

PRODUCT FAMILY FDH-9 AND FDH-11

The FDH-9/11 family are fast switching and general purpose diodes similar to the FDH-6 family except for a slightly lower forward conductance. The FDH-9/11 are assembled in the smaller DO-35 package. This family includes the 1N4148, 1N4153, FDH900 and others. These diodes couple extremely fast switching speed with a selective forward conductance.

TEST DESCRIPTION	LENGTH OF TEST	OBSERVED FAILURE RATE
Temperature Cycling Method 1051, Cond. C	10 Cycles	0.3%
Thermal Shock Method 1056, Cond. A	10 Cycles	0.0%
Moisture Resistance Method 1021	10 Days	0.0%
Shock 1,500G, 5 blows t = 0.5 ms, Method 2016		0.0%
Vibration Variable Frequency 20G (pk) Method 2056	48 Minutes	0.0%
Constant Acceleration 20,000G (pk) Method 2006	3 Minutes	0.0%
Lead Fatigue Method 2036, Cond. E	6 Seconds	0.0%
Salt Atmosphere, Method 1041	24 Hours	0.0%
Surge Current IF = 50 mA if (surge) = 500 mA (pk) tp-1/ 120 s	10 Surges	0.0%
Surge Current IF = 50 mA if (surge) = 500 mA (pk) tp = 1 s	10 Surges	0.0%
Surge Current IF = 50 mA if (surge) = 2.0 A (pk) tp = 1 μs Method 4066	10 Surges	0.0%
VF pull IF = 100 mA, 10 lbs.	15 Seconds	0.2%
High Temperature Storage 200°C	1000 Hours	0.0%
AC Operating Life IO = 200 mA, VR = 50 V, TA = 25°C	0-168 Hours	1.6%
	168-1000 Hours	0.86%
High Temperature Reverse Bias TA = 150°C, VR = 50 V	0-168 Hours	1.3%
	168-1000 Hours	0.6%

FAILURE DEFINITION:

Breakdown Voltage

IR = 5 μA
BV > 75 V

Reverse Current

VR = 50 V
IR < 200 nA

Forward Voltage

IF = 100 mA
VF < 1.0 V

Capacitance

VF = 0V
C > 2.0 pF

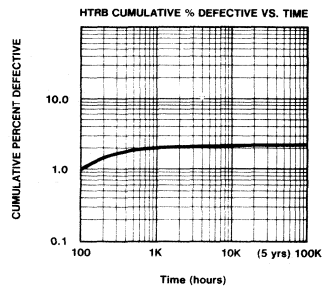
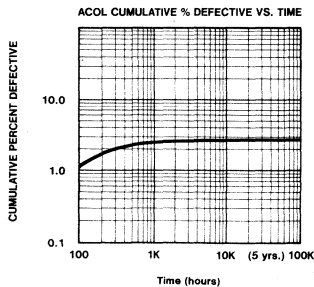

PRODUCT FAMILY DO-35 ZENERS (1/2W) METALLURGICAL BONDED

The Fairchild 500 mW metallurgical bonded zeners include the JAN1N962B-1 through JAN1N973B-1, JAN1N753A-1 through JAN1N759A-1 and others, packaged in the DO-35 glass package. The metallurgical bond provides for improved VF pull characteristics and better performance during thermal stressing.

TEST DESCRIPTION	LENGTH OF TEST	OBSERVED FAILURE RATE
Temperature cycling Test Cond. C, Method 1051	25 Cycles	0.04%
Thermal Shock Test Cond. A, Method 1056	5 Cycles	0.00%
Lead Tension Test Cond. A, Method 2036	15 Seconds	0.00%
Hermetic Seal, Cond. G, Method 1071		0.00%
Moisture Resistance, Method 1021	10 Days	0.00%
Shock non-operating, 1500 G, 5 blows, t = .5 ms, Method 2016		0.00%
Thermal Resistance, MIL-S-19500/117E, R θ_{JL} = 100°C/W		0.00%
Vibration Variable Frequency non-operating 30 G pk, Method 2056	48 Minutes	0.00%
Resistance to solvents, MIL-STD-202, Method 215		0.00%
Constant Acceleration non-operating, 20 KG Method 2006	1 Minute	0.00%
Salt Atmosphere Corrosion, Method 1041.1	24 Hours	0.00%
Lead Fatigue Method 2036.3, Cond. E	5 Seconds	0.00%
Surge Current, Ps = 2 W; tp = 1/120 s, - 1/2 square wave pulse	5 Surges	0.00%
High Temperature Storage 175°C	1000 Hours	0.80%
Zener Operating Life, 0-340-1000 Hours	0-168	0.18%
	168-1000	0.61%
Barometric Pressure Reduced, 8 mmHg	60 Seconds	0.00%
Temperature Coefficient of Breakdown Voltage (TCBV) Method 4071		0.10%
Solderability, Method 2026	5 \pm 1/2 Seconds	0.00%

2

FAILURE DEFINITION: Devices are tested to the JEDEC Electrical Limits for that particular device type.

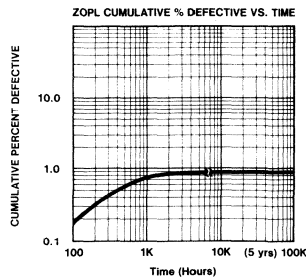

IN-USE RELIABILITY

To determine the reliability of a diode in its actual application, the following procedure will give a best estimate based on the data previously presented.

1. Determine what form of life testing is best for the specific application, e.g. ACOL or HTRB.
2. Determine what the average junction temperature (Tj) will be in the application. Do this by adding to the ambient temperature (TA), the increase of the junction temperature (ΔT) due to power being dissipated in the device. This gives you $T_j = T_A + \Delta T$. Figure 1 below gives the typical ΔT for any given power input. For HTRB $T_j = T_A$.
3. Knowing the junction temperature (Tj), the factor for derated conditions (FD) can be obtained in Figure 2. This represents the typical difference in the failure rate at the maximum rated condition ($T_j = 175^\circ\text{C}$), and the actual use conditions. This curve follows these equations.

$$\log_{10} FD = \frac{T_j}{50} - 3.5 \text{ for DCOL, ACOL } \log_{10} FD = \frac{T_j}{41.7} - 3.0 \text{ for HTRB}$$

It is the result of extended studies where it was found that failure rates drop an order of magnitude for every 50°C drop in junction temperature. This follows provided the standard manufacturing methods of removing defective parts have been completed, (i.e. temperature cycle, heat soak, pressure bomb and normal electrical screening.)

This derating will generally apply to Fairchild diodes, but cannot be guaranteed to apply to other devices.

4. For any given time span, the failure rate at maximum rated conditions can be obtained from the graphs under each specific product family.
5. Now, by multiplying this failure rate with the factor for derated conditions, we obtain a reasonably accurate estimate of the expected failure rate for the actual in-use conditions.

Example: Supposing the expected number of failures in a given system is required for a 1N4148-1 diode over a 5-year period. The application of the diode is switching, which demands both forward current and reverse blocking capabilities. The environment will be 50°C and the diode will typically dissipate 100 mW of power.

First, the switching application demands the use of ACOL data. Then, from the power vs. ΔT graph (Figure 1) the 100 mW power level will increase the junction temperature by 35°C. Combining this increase with the ambient temperature of 50°C, the junction temperature is found to be 85°C.

$$T_j = T_A + \Delta T = 50^\circ\text{C} + 35^\circ\text{C} = 85^\circ\text{C}$$

Then from Figure 2 in Item 3 the factor for derated condition is found. For $T_j = 85^\circ\text{C}$, FD is 0.016.

Now from the ACOL extrapolated graph under the FDH-6 family in Section IV, the cumulative percent defective for five years is found to be 0.5%.

Because this percent defective is for maximum rated conditions, it must now be multiplied by Fd to determine the percent defective for in-use conditions.

Expected failures = 0.5% X .016 = 0.008% over the five year period.

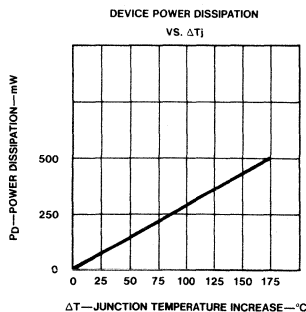

Fig 1.

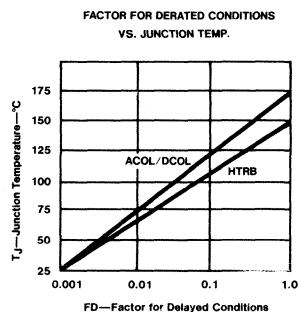
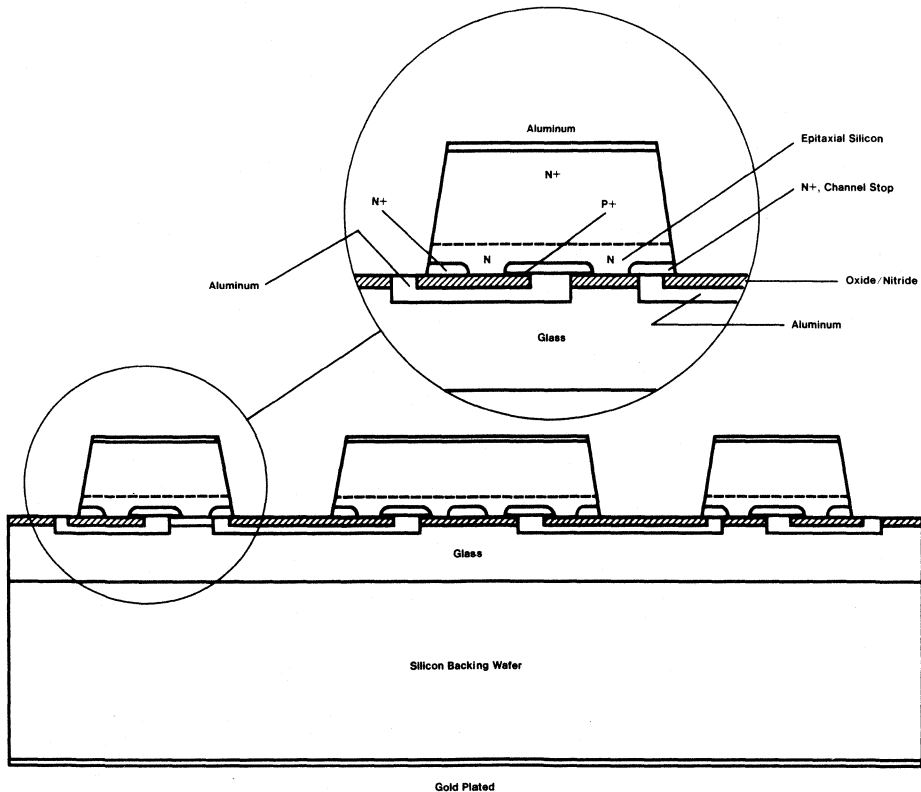

Fig 2.

MONOLITHIC DIODE ARRAY FAMILY

The air-isolated monolithic diode array family consists of a number of diode circuits which have been fabricated in integrated form rather than as discrete diodes. The circuits available include a 16-diode core driver matrix, an 8-diode core driver matrix, a bridge, arrays of common cathode and common anode diodes, groups of individual closely matched diodes and various custom configurations. These circuits are packaged in plastic and ceramic 14-lead and 16-lead dual-in-line packages, 10 and 14-lead ceramic flat packs and a 10-lead TO-5 packages. The bridge circuit is available in 4-lead TO-5 and TO-18 packages.

The diodes in the monolithic array family are by design equivalent to the FDH6 high-speed switching diode. When the fabrication of the diodes in wafer form is complete, the circuit is interconnected with aluminum and the wafer is attached to a second wafer using a special glass as the adhesive medium. Through this construction, the entire active portion of the device is buried in such a manner as to be unreachable by any contaminant once the device is in service.



TYPICAL CONSTRUCTION OF A FAIRCHILD MONOLITHIC DIODE ARRAY

MONOLITHIC DIODE ARRAY

TEST DESCRIPTION	LENGTH OF TEST	OBSERVED FAILURE RATE
Temperature Cycling Method 1051, Cond. C	10 Cycles	0.0%
Thermal Shock Method 1056 Cond. A	10 Cycles	0.0%
Moisture Resistance Method 1021	10 Days	0.0%
Shock 1500G t = 0.5 ms. Method 2016	5 Blows	0.0%
Vibration Variable Frequency 20G (pk) Method 2056	48 Minutes	0.0%
Vibration Fatigue 20 G (pk), Method 2046	96 Hours	0.0%
Constant Acceleration 20 k G (pk) Method 2006	3 Minutes	0.0%
Lead Fatigue 45° arcs, Method 2036, Cond. E	6 Seconds	0.0%
Salt Atmosphere, Method 1041	24 Hours	0.0%
Hermetic Seal, Fine and Gross, Method 1071		0.05%
Surge Current IF = 50 mA IF (surge) = 500 mA (pk) tp = 1/120 s, Method 4066	10 Surges	0.0%
High Temperature Storage, 200°C	1000 Hours	0.0%
AC Operating Life; IO = 300 mA/package VR = 50 V, TA = 25°C	0-168 Hours	0.18%
	168-1000 Hours	0.06%
High Temperature Reverse Bias; TA= 150°C VR = 50 V	0-168 Hours	0.21%
	168-1000 Hours	0.12%

FAILURE DEFINITION:

Breakdown Voltage

IR = 10 μA
BV > 60 V

Reverse Current

VR = 40 V
IR < 200 nA

Forward Voltage

IF = 500 mA
VF < 1.5 V

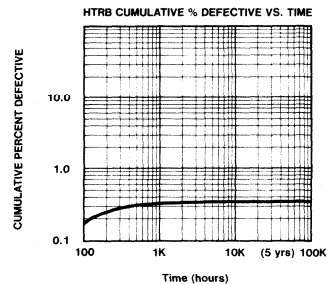
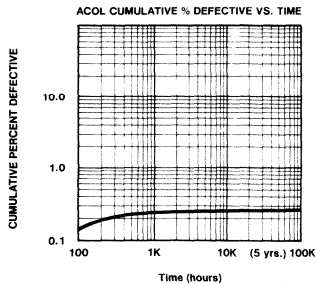

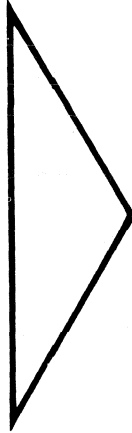
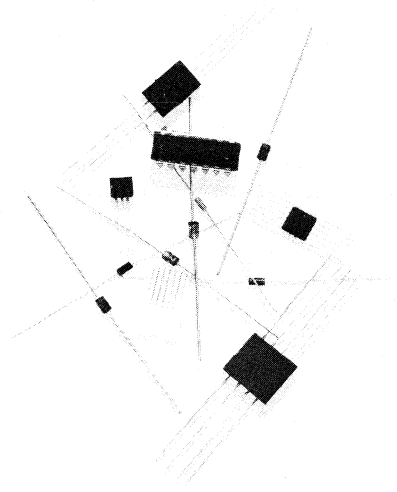

DEVICE SELECTION GUIDES

1

RELIABILITY

2

PRODUCT INFORMATION

3

FAMILY CURVES

4

GLOSSARY OF SYMBOLS AND TERMS

5

FAIRCHILD FIELD SALES OFFICES,
SALES REPRESENTATIVES AND
DISTRIBUTOR LOCATIONS

6

BAV17 • BAV18 • BAV19 • BAV20 • BAV21

GENERAL PURPOSE DIODES

DIFFUSED SILICON PLANAR

- $V_F \dots 1.0 \text{ V (Max) @ } 100 \text{ mA}$
- $I_R \dots 100 \text{ nA @ WIV}$

ABSOLUTE MAXIMUM RATINGS (Note 1)

Temperatures

Storage Temperature Range	-65°C to +200°C
Maximum Junction Operating Temperature	+175°C
Lead Temperature	+260°C

Power Dissipation (Note 2)

Maximum Total Power Dissipation at 25°C Ambient	500 mW
Linear Power Derating Factor (from 25°C)	3.33 mW / °C

Maximum Voltage and Currents

WIV	Working Inverse Voltage	BAV 17	20 V
		BAV 18	50 V
		BAV 19	100 V
		BAV 20	150 V
		BAV 21	200 V

I_O	Average Rectified Current	100 mA
I_F	Continuous Forward Current	300 mA
i_f	Peak Repetitive Forward Current	400 mA
$i_f(\text{surge})$	Peak Forward Surge Current	
	Pulse Width=1 μs	4 A
	Pulse Width=1 s	1 A

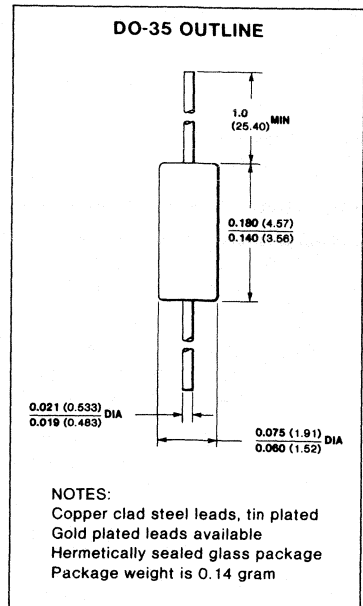

3

ELECTRICAL CHARACTERISTICS (25°C Ambient Temperature unless otherwise noted)

SYMBOL	CHARACTERISTIC	MIN	TYP	MAX	UNITS	TEST CONDITIONS
V_F	Forward Voltage			1.00	V	$I_F = 100 \text{ mA}$
				1.25	V	$I_F = 200 \text{ mA}$
I_R	Reverse Current	BAV 21		100	nA	$V_R = 200 \text{ V}$
				15	μA	$V_R = 200 \text{ V}, T_A = 100^\circ\text{C}$
		BAV 20		100	nA	$V_R = 150 \text{ V}$
				15	μA	$V_R = 150 \text{ V}, T_A = 100^\circ\text{C}$
		BAV 19		100	nA	$V_R = 100 \text{ V}$
				15	μA	$V_R = 100 \text{ V}, T_A = 100^\circ\text{C}$
BV	Breakdown Voltage	BAV 21	250		V	$I_R = 100 \mu\text{A}$
		BAV 20	200		V	$I_R = 100 \mu\text{A}$
		BAV 19	120		V	$I_R = 100 \mu\text{A}$
		BAV 18	60		V	$I_R = 100 \mu\text{A}$
		25		V	$I_R = 100 \mu\text{A}$	
C	Capacitance		1.5	5.0	pF	$V_R = 0, f = 1 \text{ MHz}$
t_{rr}	Reverse Recovery Time (Note 3)			50	ns	$I_F = 30 \text{ mA}, I_R = 30 \text{ mA}, R_L = 100 \Omega$
diff	Differential Resistance		5.0		Ω	$I_F = 10 \text{ mA}$

NOTES:

1. These ratings are limiting values above which the serviceability of the diode may be impaired.
2. These are steady state limits. The factory should be consulted on applications involving pulsed or low duty-cycle operation.
3. Recovery to $I_F = 3 \text{ mA}$.
4. For product family characteristic curves, refer to Chapter 4 BAV 17/18 D4, BAV 19/20/21 D1.

BAW75 • BAW76

HIGH SPEED COMPUTER DIODES

SILICON PLANAR EPITAXIAL

- t_{rr} ... 4 ns (max)
- C ... 4 pf (max)

ABSOLUTE MAXIMUM RATINGS (Note 1)

Temperatures

Storage Temperature Range	-65°C to +200°C
Maximum Junction Operating Temperature	+175°C
Lead Temperature	+260°C

Power Dissipation (Note 2)

Maximum Total Power Dissipation at 25°C Ambient	500 mW
Linear Power Derating Factor (from 25°C)	3.33 mW/°C

Maximum Voltage and Currents

WIV	Working Inverse Voltage	BAW 75	25V
		BAW 76	50V
I_O	Average Rectified Current		100 mA
I_F	Continuous Forward Current		300 mA
i_f	Peak Repetitive Forward Current		400 mA
i_f (surge)	Peak Forward Surge Current		4.0 A
	Pulse Width = 1 s		1.0 A
	Pulse Width = 1 μ s		4.0 A

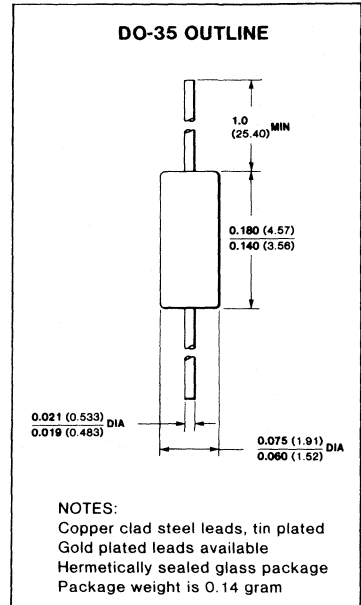

ELECTRICAL CHARACTERISTICS (25°C Ambient Temperature unless otherwise noted)

SYMBOL	CHARACTERISTIC	BAW 75		BAW 76		UNITS	TEST CONDITIONS
		MIN	MAX	MIN	MAX		
V_F	Forward Voltage		1.0		1.0	V	$I_F = 30$ mA
						V	$I_F = 100$ mA
I_R	Reverse Current		100		100	nA	$V_R = 25$ V
			100		100	nA	$V_R = 50$ V
					100	μ A	$V_R = 25$ V, $T_A = 150^\circ$ C
					100	μ A	$V_R = 50$ V, $T_A = 150^\circ$ C
B_V	Breakdown Voltage	35		75		V	$I_R = 5.0$ μ A
C	Capacitance		4.0		2.0	pF	$V_R = 0$, $f = 1$ MHz
t_{rr}	Reverse Recovery Time		4.0		4.0	ns	$I_f = I_r = 10$ mA
			2.0		2.0	ns	Recovery to 1 mA
							$I_f = 10$ mA, $V_R = 6$ V,
							$R_L = 100 \Omega$

NOTES:

1. These ratings are limiting values above which the serviceability of the diode may be impaired.
2. These are steady state limits. The factory should be consulted on applications involving pulsed or low duty-cycle operation.
3. For product family characteristic curves, refer to Chapter 4, D4.

BAX13

HIGH SPEED SWITCHING DIODE

DIFFUSED SILICON PLANAR

- C... 3.0 pF (MAX)
- t_{rr} ... 4.0 ns (MAX)

ABSOLUTE MAXIMUM RATINGS (Note 1)

Temperatures

Storage Temperature Range	-65°C to +200°C
Maximum Operating Junction Temperature	+175°C
Lead Temperature	+260°C

Power Dissipation (Note 2)

Maximum Total Dissipation at 25°C Ambient	500 mW
Linear Derating Factor (from 25°C)	3.33 mW/°C

Maximum Voltages and Currents

V _{RRM}	Repetitive Peak Reverse Voltage	50 V
V _R	Reverse Voltage	50 V
I _O	Average Rectified Current	100 mA
I _F	Forward Current	300 mA
i _f	Recurrent Peak Forward Current	400 mA
I _{FSM}	Peak Forward Surge Current	
	Pulse Width = 1.0 s	1.0 A
	Pulse Width = 1.0 μs	4.0 A

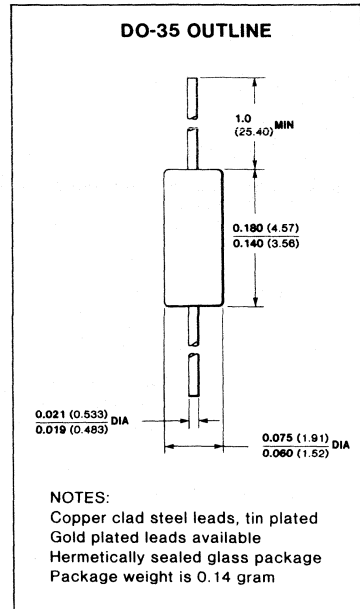

3

ELECTRICAL CHARACTERISTICS (25°C Ambient Temperature unless otherwise noted)

SYMBOL	CHARACTERISTIC	MIN	MAX	UNITS	TEST CONDITIONS
V _F	Forward Voltage		0.7	V	I _F = 2.0 mA
			0.8	V	I _F = 10 mA, T _A = 100°C
			1.0	V	I _F = 20 mA
			1.53	V	I _F = 75 mA
I _R	Reverse Current		25	nA	V _R = 10 V
			10	μA	V _R = 10 V, T _A = 150°C
			50	nA	V _R = 25 V
			200	nA	V _R = 50 V
			25	μA	V _R = 50 V, T _A = 150°C
C	Capacitance		3.0	pF	V _R = 0, f = 1.0 MHz
t _{rr}	Reverse Recovery Time		4.0	ns	I _f = 10 mA, V _r = 6.0 V, R _L = 100Ω, I _r = 1.0 mA
Q _S	Recovered Charge		45	pC	I _f = 10 mA, V _r = 5.0 V, R _L = 500Ω

NOTES:

1. These ratings are limiting values above which the serviceability of any individual semiconductor device may be impaired.
2. These are steady state limits. The factory should be consulted on applications involving pulsed or low duty cycle operations.
3. For product family characteristic curves, refer to Chapter 4, D4.

BAX16

GENERAL PURPOSE INDUSTRIAL DIODE

DIFFUSED SILICON PLANAR

- BV... 180 V (MIN) @ 100 μ A
- I_R... 100 nA (MAX) @ 150 V

ABSOLUTE MAXIMUM RATINGS (Note 1)

Temperatures

Storage Temperature Range	-65°C to +200°C
Maximum Junction Operating Temperature	+175°C
Lead Temperature	+260°C

Power Dissipation (Note 2)

Maximum Total Power Dissipation at 25°C Ambient	500 mW
Linear Power Derating Factor (from 25°C)	3.33 mW/°C

Maximum Voltage and Currents

WIV	Working Inverse Voltage	150 V
I _O	Average Rectified Current	200 mA
I _F	Continuous Forward Current	500 mA
i _f	Peak Repetitive Forward Current	600 mA
i _f (surge)	Peak Forward Surge Current	
	Pulse Width = 1 s	1.0 A
	Pulse Width = 1 μ s	4.0 A

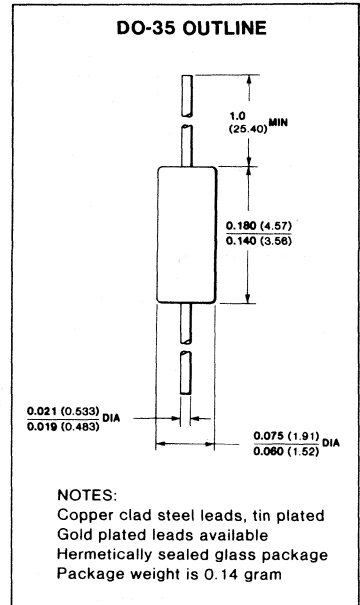

ELECTRICAL CHARACTERISTICS (25°C Ambient Temperature unless otherwise noted)

SYMBOL	CHARACTERISTIC	MIN	MAX	UNITS	TEST CONDITIONS
V _F	Forward Voltage		1.5	V	I _F = 200 mA
			1.4	V	I _F = 200 mA, T _A = 175°C
			1.3	V	I _F = 100 mA
			0.85	V	I _F = 10 mA, T _A = 100°C
			0.65	V	I _F = 1 mA
I _R	Reverse Current		100	nA	V _R = 150 V
			100	μ A	V _R = 150 V, T _A = 150°C
			25	nA	V _R = 50 V
			25	μ A	V _R = 50 V, T _A = 150°C
BV	Breakdown Voltage	180		V	I _R = 100 μ A
C	Capacitance		10	pF	V _R = 0, f = 1 MHz
t _{rr}	Reverse Recovery Time (Note 3)		120	ns	I _F = 30 mA, I _R = 30 mA R _L = 100 Ω
Q _s	Stored Charge		700	pC	I _F = 10 mA, V _R = 5 V R _L = 500 Ω

NOTES:

1. These ratings are limiting values above which the serviceability of the diode may be impaired.
2. These are steady state limits. The factory should be consulted on applications involving pulsed or low duty-cycle operation.
3. Recovery to I_R = 3 mA.
4. For product family characteristic curves, refer to Chapter 4, D1.

BAY71

FAST SWITCHING DIODE

DIFFUSED SILICON PLANAR

- t_{rr} ... 4.0 ns (MAX)
- C ... 2.0 pF (MAX)

ABSOLUTE MAXIMUM RATINGS (Note 1)

Temperatures

Storage Temperature Range	-65°C to +200°C
Max Junction Operating Temperature	+175°C
Lead Temperature	+260°C

Power Dissipation (Note 2)

Maximum Total Dissipation at 25°C Ambient	500 mW
Linear Derating Factor (from 25°C)	3.33 mW/°C

Maximum Voltage and Currents

WIV	Working Inverse Voltage	35 V
I_O	Average Rectified Current	100 mA
I_F	Forward Current Steady State DC	300 mA
I_f	Recurrent Peak Forward Current	400 mA
$i_f(\text{surge})$	Peak Forward Surge Current	
	Pulse Width = 1.0 s	1.0 A
	Pulse Width = 1.0 μ s	4.0 A

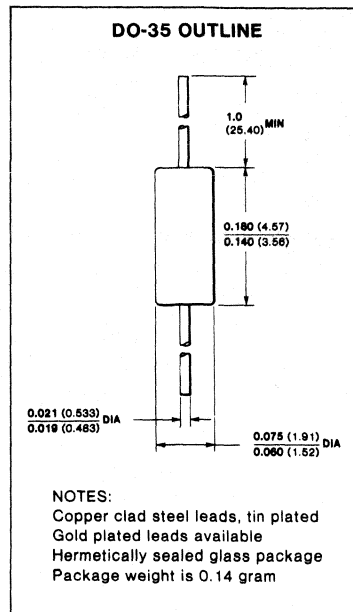

3

ELECTRICAL CHARACTERISTICS (25°C Ambient Temperature unless otherwise noted)

SYMBOL	CHARACTERISTIC	MIN	MAX	UNITS	TEST CONDITIONS
V_F	Forward Voltage	0.76	1.00	V	$I_F = 20$ mA
		0.69	0.88	V	$I_F = 10$ mA
		0.57	0.69	V	$I_F = 1.0$ mA
		0.46	0.56	V	$I_F = 0.1$ mA
I_R	Reverse Current		100 100	nA μ A	$V_R = 35$ V $V_R = 35$ V, $T_A = 125^\circ$ C
BV	Breakdown Voltage	50		V	$I_R = 5.0$ μ A
t_{rr}	Reverse Recovery Time (Note 5)		2.0	ns	$I_F = 10$ mA, $I_R = 6.0$ mA, $R_L = 100 \Omega$, $V_R = 6.0$ V
V_{fr}	Forward Recovery Peak Voltage (Note 3)		3.0	V	$I_F = 100$ mA (pulsed)
t_{fr}	Forward Recovery Time (Note 3)		40	ns	$I_F = 100$ mA (pulsed)
Q_S	Stored Charge (Note 4)		65	pC	$I_F = 20$ mA, $I_R = 2.0$ mA
			50	pC	$I_F = 10$ mA, $I_R = 1.0$ mA
RE	Rectification Efficiency (Note 6)	45		%	$f = 100$ MHz
C	Capacitance		2.0	pF	$V_R = 0$, $f = 1.0$ MHz

NOTES:

1. The maximum ratings are limiting values above which life or satisfactory performance may be impaired.
2. These are steady state limits. The factory should be consulted on applications involving pulsed or low duty cycle operations.
3. The oscilloscope used as the response detector shall have a bandwidth of at least 10 MHz (3 dB down), and shall be calibrated using a deposited carbon resistor of 50 Ω in the diode test clips. t_{fr} is defined as the difference between the 10% point of the pulse and the point where V_F is within 10% of the quiescent value.
4. Measured on the Tektronix "S" unit.
5. Recovery to 1.0 mA.
6. Rectification efficiency is defined as the ratio of dc load voltage to peak rf input voltage to the detector circuit, measured with 2.0 V rms input to the circuit. Load resistance 5.0 k Ω , load capacitance 20 pF.
7. For product family curves, refer to Chapter 4, D4.

BAY72 • BAY80

GENERAL PURPOSE, HIGH CONDUCTANCE DIODES

DIFFUSED SILICON PLANAR

- $V_F \dots 1.0 \text{ V (MAX) @ } 100 \text{ mA (BAY72)}$
- $V_F \dots 1.0 \text{ V (MAX) @ } 150 \text{ mA (BAY80)}$

ABSOLUTE MAXIMUM RATINGS (Note 1)

Temperatures

Storage Temperature Range	-65°C to +200°C
Maximum Junction Operating Temperature	+175°C
Lead Temperature	+260°C

Power Dissipation (Note 2)

Maximum Total Power Dissipation at 25°C Ambient	500 mW
Linear Power Derating Factor (from 25°C)	3.33 mW / °C

Maximum Voltage and Currents

WIV	Working Inverse Voltage	BAY 72	100 V
		BAY 80	120 V
I_O	Average Rectified Current		200 mA
I_F	Continuous Forward Current		500 mA
i_f	Peak Repetitive Forward Current		600 mA
$i_f(\text{surge})$	Peak Forward Surge Current		
	Pulse Width = 1 s		1.0 A
	Pulse Width = 1 μ s		4.0 A

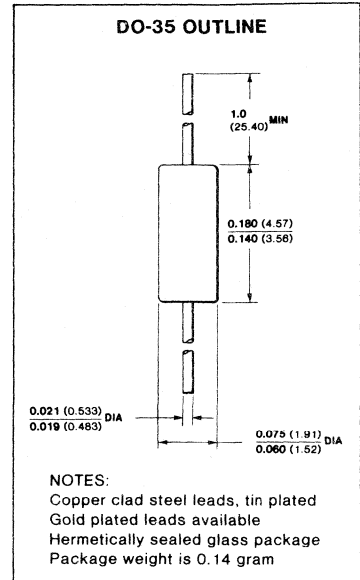

ELECTRICAL CHARACTERISTICS (25°C Ambient Temperature unless otherwise noted)

SYMBOL	CHARACTERISTIC	BAY 72		BAY 80		UNITS	TEST CONDITIONS
		MIN	MAX	MIN	MAX		
V_F	Forward Voltage				1.00	V	$I_F = 150 \text{ mA}$
		0.78	1.00			V	$I_F = 100 \text{ mA}$
		0.73	0.92			V	$I_F = 50 \text{ mA}$
		0.63	0.78			V	$I_F = 10 \text{ mA}$
		0.51	0.64			V	$I_F = 1.0 \text{ mA}$
I_R	Reverse Current				100	nA	$V_R = 120 \text{ V}$
					150	μ A	$V_R = 120 \text{ V}, T_A = 100^\circ\text{C}$
			100			nA	$V_R = 100 \text{ V}$
			100			μ A	$V_R = 100 \text{ V}, T_A = 125^\circ\text{C}$
BV	Breakdown Voltage	125		150		V	$I_R = 100 \mu\text{A}$
C	Capacitance		5.0		6.0	pF	$V_R = 0, f = 1 \text{ MHz}$
t_{rr}	Rev. Rec. Time (note 3) (note 4)		50		60	ns	$I_f = I_r = 30 \text{ mA}, R_L = 75 \Omega$
			400			ns	$I_f = 30 \text{ mA}, V_R = 35 \text{ V}$
V_{fr}	Fwd. Rec. Voltage (note 5)		2.5			v	$R_L = 2.0 \text{ K}\Omega, C_L = 10 \text{ pF}$
V_{fr}	Fwd. Rec. Voltage (note 5)		2.5			V	$I_f = 100 \text{ mA (pulsed)}$
t_{fr}	Fwd. Rec. Time (note 5)		50			ns	$I_f = 100 \text{ mA (pulsed)}$
Q_s	Stored Charge (note 6)		250			pC	$I_f = 20 \text{ mA}, I_r = 1.0 \text{ mA}$
R_E	Rect. Efficiency (note 7)	35				%	$f = 100 \text{ MHz}$

NOTES:

1. These ratings are limiting values above which the serviceability of the diode may be impaired.
2. These are steady state limits. The factory should be consulted on applications involving pulsed or low duty-cycle operation.
3. Recovery to 1.0 mA.
4. Recovery to 400 k Ω , Jan 256 Circuit.
5. The oscilloscope used as the response detector shall have a bandwidth of at least 10 MHz (3 dB down), and shall be calibrated using a deposited carbon resistor of 50 Ω in the diode test clips. t_{rr} is defined as the difference between the 10% point of the pulse and the point where V_F is to be within 10% of the quiescent value. Pulse conditions shall be 0.1 μ s wide at base, 20 ns maximum rise time, repetition rate = 100 kHz max.
6. Measured on the Tektronix "S" unit.
7. Rectification efficiency is defined as the ratio of dc load voltage to peak rf input to the circuit. Load resistance of 5.0 k Ω , load capacitance 20 pF.
8. For product family characteristic curves, refer to Chapter 4, D1.

BAY73 • BA129

HIGH VOLTAGE, LOW LEAKAGE DIODES

DIFFUSED SILICON PLANAR

- BV... 125 V (MIN) @ 100 μ A (BAY73)
- BV... 200 V (MIN) @ 100 μ A (BA129)

ABSOLUTE MAXIMUM RATINGS (Note 1)

Temperatures

Storage Temperature Range	-65°C to +200°C
Maximum Junction Operating Temperature	+175°C
Lead Temperature	+260°C

Power Dissipation (Note 2)

Maximum Total Power Dissipation at 25°C Ambient	500 mW
Linear Power Derating Factor (from 25°C)	3.33 mW/°C

Maximum Voltage and Currents

WIV	Working Inverse Voltage	BAY73	100 V
		BA129	180 V
I_O	Average Rectified Current		200 mA
I_F	Continuous Forward Current		500 mA
i_f	Peak Repetitive Forward Current		600 mA
$i_f(\text{surge})$	Peak Forward Surge Current		
	Pulse Width = 1 s		1.0 A
	Pulse Width = 1 μ s		4.0 A

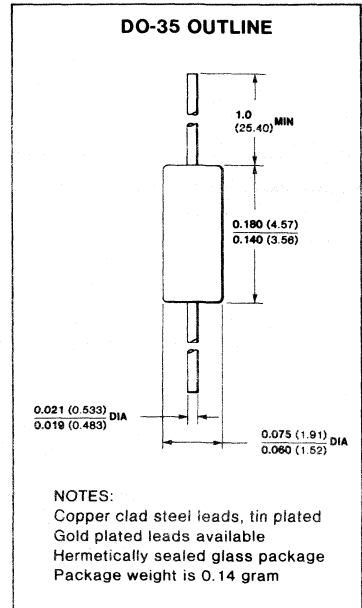

ELECTRICAL CHARACTERISTICS (25°C Ambient Temperature unless otherwise noted)

SYMBOL	CHARACTERISTIC	BAY73		BA129		UNITS	TEST CONDITIONS
		MIN	MAX	MIN	MAX		
V_F	Forward Voltage	0.85	1.00			V	$I_F = 200$ mA
		0.81	0.94			V	$I_F = 100$ mA
		0.78	0.88	0.78	1.00	V	$I_F = 50$ mA
		0.69	0.80	0.69	0.83	V	$I_F = 10$ mA
		0.67	0.75			V	$I_F = 5.0$ mA
		0.60	0.68	0.60	0.71	V	$I_F = 1.0$ mA
					0.51	0.60	V
I_R	Reverse Current		500			nA	$V_R = 20$ V, $T_A = 125^\circ$ C
			5.0			nA	$V_R = 100$ V
			1.0			μ A	$V_R = 100$ V, $T_A = 125^\circ$ C
					10	nA	$V_R = 180$ V
					5.0	μ A	$V_R = 180$ V, $T_A = 100^\circ$ C
BV	Breakdown Voltage	125		200		V	$I_R = 100$ μ A
C	Capacitance		8.0		6.0	pF	$V_R = 0$, $f = 1.0$ MHz
t_{rr}	Reverse Recovery Time		3.0			μ s	$I_f = 10$ mA, $V_r = 35$ V $R_L = 1.0$ to 100 K Ω $C_L = 10$ pf, JAN 256

NOTES:

1. These ratings are limiting values above which the serviceability of the diode may be impaired.
2. These are steady state limits. The factory should be consulted on applications involving pulses or low duty-cycle operation.
3. For product family characteristic curves, refer to Chapter 4, D2

BAY74

HIGH CONDUCTANCE ULTRA FAST DIODE

SILICON PLANAR EPITAXIAL

- t_{rr} ... 4.0 ns (MAX)
- C ... 3.0 pF (MAX)

ABSOLUTE MAXIMUM RATINGS (Note 1)

Temperatures

Storage Temperature Range	-65° C to +200° C
Maximum Operating Junction Temperature	+175° C
Lead Temperature	+260° C

Power Dissipation (Note 2)

Maximum Total Dissipation at 25° C Ambient	500 mW
Linear Deviation Factor (from 25° C)	3.33 mW

Maximum Voltage and Currents

WIV	Working Inverse Voltage	35 V
I _O	Average Rectified Current	100 mA
I _F	Continuous Forward Current	300 mA
i _f	Recurrent Peak Forward Current	400 mA
i _f (surge)	Peak Forward Surge Current	
	Pulse Width = 1.0 s	1.0 A
	Pulse Width = 1.0 μs	4.0 A

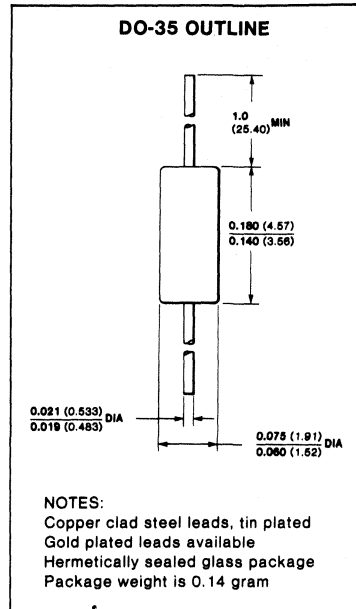

ELECTRICAL CHARACTERISTICS (25° C Ambient Temperature unless otherwise noted)

SYMBOL	CHARACTERISTIC	MIN	MAX	UNITS	TEST CONDITIONS
V _F	Forward Voltage	0.85	1.10	V	I _F = 300 mA
		0.82	1.00	V	I _F = 200 mA
		0.78	0.93	V	I _F = 100 mA
		0.73	0.88	V	I _F = 50 mA
		0.65	0.77	V	I _F = 10 mA
		0.54	0.65	V	I _F = 1.0 mA
I _R	Reverse Current		100	nA	V _R = 35 V
			100	μA	V _R = 35 V, T _A = 125° C
BV	Breakdown Voltage	50		V	I _R = 5.0 μA
C	Capacitance		3.0	pF	V _R = 0, f = 1.0 MHz
t _{rr}	Reverse Recovery Time (Note 4)		4.0	ns	I _f = I _r = 10 mA to 200 mA
			6.0	ns	I _f = I _r = 200 mA to 400 mA
t _{rr}	Reverse Recovery Time (Note 3)		6.0	ns	I _f = 10 mA, I _r = 1.0 mA

NOTES:

1. The maximum ratings are limiting values above which life or satisfactory performance may be impaired.
2. These are steady-state limits. The factory should be consulted on applications involving pulses or low duty-cycle operations.
3. Recovery to 0.1 mA.
4. Recovery to 10% of I_f.
5. For product family characteristic curves, refer to Chapter 4, D4.

BAY82 • 1N4244 • 1N4376

ULTRA-FAST SWITCHING DIODES

DIFFUSED SILICON PLANAR

- t_{rr} ... 750 ps (MAX)
- C ... 0.8 pF (MAX) 1N4244

ABSOLUTE MAXIMUM RATINGS (Note 1)

Temperatures

Storage Temperature Range	-65°C to +200°C
Maximum Junction Operating Temperature	+175°C
Lead Temperature	+260°C

Power Dissipation (Note 2)

Maximum Total Power Dissipation at 25°C Ambient	250 mW
Linear Power Derating Factor (from 25°C)	1.67 mW / °C

Maximum Voltage and Currents

WIV	Working Inverse Voltage	10 V (12 V BAY82)
I_O	Average Rectified Current	50 mA
I_F	Continuous Forward Current	150 mA
i_f	Peak Repetitive Forward Current	150 mA
$i_f(\text{surge})$	Peak Forward Surge Current	250 mA
	Pulse Width = 1 s	

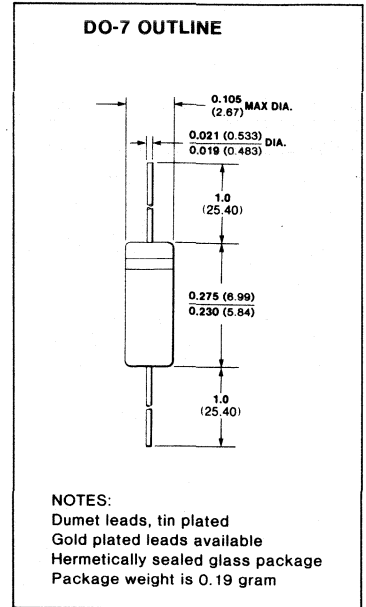

ELECTRICAL CHARACTERISTICS (25°C Ambient Temperature unless otherwise noted)

SYMBOL	CHARACTERISTIC	BAY82		1N4244		1N4376		UNITS	TEST CONDITIONS
		MIN	MAX	MIN	MAX	MIN	MAX		
V_F	Forward Voltage	0.90	1.35			0.89	1.10	V	$I_F = 50$ mA $I_F = 20$ mA $I_F = 10$ mA $I_F = 1.0$ mA $I_F = 0.1$ mA $I_F = 10$ μ A
		0.80	1.00		1.00	0.81	0.95	V	
		0.77	0.94			0.76	0.88	V	
		0.64	0.79			0.64	0.74	V	
		0.53	0.66			0.52	0.61	V	
		0.41	0.53			0.42	0.50	V	
I_R	Reverse Current				100		100	nA	$V_R = 10$ V $V_R = 10$ V, $T_A = 150^\circ$ C $V_R = 12$ V $V_R = 12$ V, $T_A = 100^\circ$ C $V_R = 15$ V
					100		100	μ A	
			100					nA	
			50		250			μ A	
								nA	
BV	Breakdown Voltage	15		20		20		V	$I_R = 5.0$ μ A
C	Capacitance		1.3		0.8		1.0	pF	$V_R = 0$, $f = 1$ MHz
t_{rr}	Reverse Recovery Time (Note 3)		750		750		750	ps	$I_F = I_R = 10$ mA $R_L = 100$ Ω

NOTES:

1. These ratings are limiting values above which the serviceability of the diode may be impaired.
2. These are steady state limits. The factory should be consulted on applications involving pulsed or low duty-cycle operation.
3. Recovery to $I_F = 1.0$ mA.
4. For product family characteristic curves, refer to Chapter 4, D3.

BA 128 • BA 130

GENERAL PURPOSE DIODES

DIFFUSED SILICON PLANAR

- WIV ... 50 V (BA 128), 25 V (BA 130)
- I_R ... 100 nA (MAX) @ WIV

ABSOLUTE MAXIMUM RATINGS (Note 1)

Temperatures

Storage Temperature Range	-65°C to +200°C
Maximum Junction Operating Temperature	175°C
Lead Temperature (10 seconds)	260°C

Power Dissipation (Note 2)

Maximum Total Power Dissipation at 25°C Ambient	500 mW
Linear Power Derating Factor (from 25°C)	3.33 mW / °C

Maximum Voltage and Currents

WIV	Working Inverse Voltage	BA 128	50 V
		BA 130	25 V
I _O	Average Rectified Current		200 mA
I _F	Continuous Forward Current		500 mA
i _f	Peak Repetitive Forward Current		600 mA
i _f (surge)	Peak Forward Surge Current		1.0 A
	Pulse Width = 1 s		4.0 A
	Pulse Width = 1 μs		

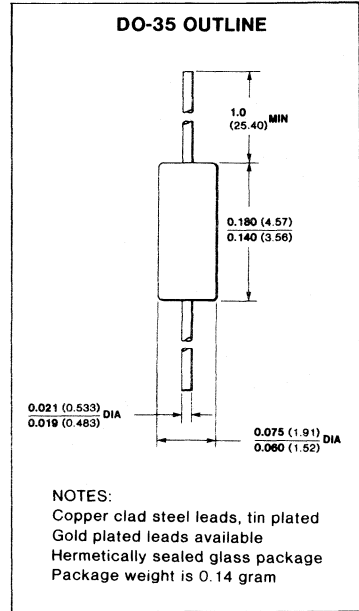

ELECTRICAL CHARACTERISTICS (25°C Ambient Temperature unless otherwise noted)

SYMBOL	CHARACTERISTIC	BA 128		BA 130		UNITS	TEST CONDITIONS
		MIN	MAX	MIN	MAX		
V _F	Forward Voltage	0.73	1.00			V	I _F = 50 mA
		0.63	0.79	0.69	1.00	V	I _F = 10 mA
		0.51	0.64	0.56	0.71	V	I _F = 1.0 mA
		0.40	0.52	0.45	0.58	V	I _F = 0.1 mA
				0.34	0.47	V	I _F = 0.01 mA
I _R	Reverse Current		100		100	nA	V _R = 50 V
			100		100	nA	V _R = 25 V
					100	μA	V _R = 50 V, T _A = 100°C
					μA	V _R = 25 V, T _A = 100°C	
BV	Breakdown Voltage	75		30		V	I _R = 100 μA
						V	I _R = 5 μA
C	Capacitance		5.0		2.0	pF	V _R = 0, f = 1.0 MHz

NOTES:

1. These ratings are limiting values above which the serviceability of the diode may be impaired.
2. These are steady state limits. The factory should be consulted on applications involving pulsed or low duty-cycle operation.
3. For product family characteristic curves, refer to Chapter 4, D4.

BA180 • BA181

GENERAL PURPOSE DIODES

SILICON PLANAR

- BV ... 10 V (MIN) @ 100 μ A (BA180)
- BV ... 20 V (MIN) @ 100 μ A (BA181)

ABSOLUTE MAXIMUM RATINGS (Note 1)

Temperatures

Storage Temperature Range	-65°C to +200°C
Maximum Junction Operating Temperature	+175°C
Lead Temperature	+260°C

Power Dissipation (Note 2)

Maximum Total Power Dissipation at 25°C Ambient	500 mW
Linear Power Derating Factor (from 25°C)	3.33 mW/°C

Maximum Voltage and Currents

WIV	Working Inverse Voltage	BA180	10 V
		BA181	20 V
I_O	Average Rectified Current		100 mA
I_F	Continuous Forward Current		300 mA
i_f	Peak Repetitive Forward Current		400 mA
i_f (surge)	Peak Forward Surge Current		1.0 A
	Pulse Width = 1 s		4.0 A
	Pulse Width = 1 μ s		

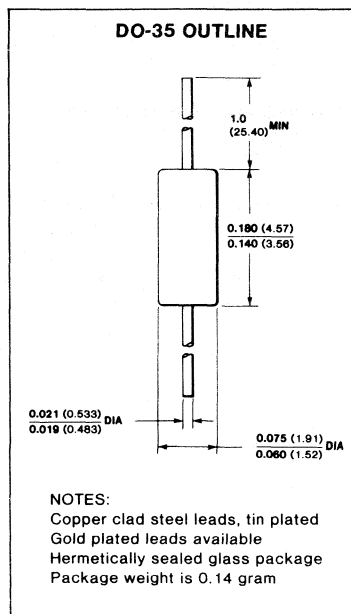

ELECTRICAL CHARACTERISTICS (25°C Ambient Temperature unless otherwise noted)

SYMBOL	CHARACTERISTIC	MIN	MAX	UNITS	TEST CONDITIONS
V_F	Forward Voltage		1.0	V	$I_F = 4$ mA
I_R	Reverse Current		1.0	μ A	$V_R = 5.0$ V
BV	Breakdown Voltage	BA180	10	V	$I_R = 100$ μ A
		BA181	20	V	$I_R = 100$ μ A

NOTES:

1. These ratings are limiting values above which the serviceability of the diode may be impaired.
2. These are steady state limits. The factory should be consulted on applications involving pulsed or low duty-cycle operation.
3. For product family characteristic curves, refer to Chapter 4, D4.

BA216 • BA217 • BA218 • BA219

GENERAL PURPOSE DIODES

DIFFUSED SILICON PLANAR

- WIV ... 10 V to 100 V
- t_{rr} ... 4 ns (MAX) BA216-218

ABSOLUTE MAXIMUM RATINGS (Note 1)

Temperatures

Storage Temperature Range	-65°C to +200°C
Maximum Junction Operating Temperature	+175°C
Lead Temperature	+260°C

Power Dissipation (Note 2)

Maximum Total Power Dissipation at 25°C Ambient	500 mW
Linear Power Derating Factor (from 25°C)	3.33 mW/°C

Maximum Voltage and Currents

WIV	Working Inverse Voltage	BA216	10 V	BA217	30 V
I_O	Average Rectified Current	BA218	50 V	BA219	100V
I_F	Continuous Forward Current				100 mA
I_f	Peak Repetitive Forward Current				300 mA
$i_f(\text{surge})$	Peak Forward Surge Current				400 mA
	Pulse Width = 1 s				1.0 A
	Pulse Width = 1 μ s				4.0 A

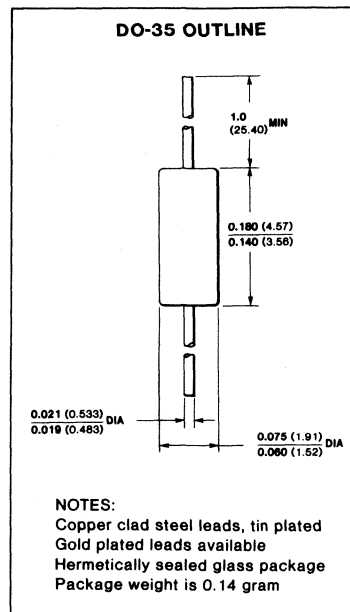

ELECTRICAL CHARACTERISTICS (25°C Ambient Temperature unless otherwise noted)

SYMBOL	CHARACTERISTIC	BA216		BA217 • BA218		BA219		UNITS	TEST CONDITIONS
		MIN	MAX	MIN	MAX	MIN	MAX		
V_F	Forward Voltage	0.70	1.00		1.50		1.40		$I_F = 100$ mA $I_F = 50$ mA $I_F = 15$ mA $I_F = 10$ mA $I_F = 3.0$ mA $I_F = 1.0$ mA $I_F = 0.2$ mA
I_R	Reverse Current		1500		50			nA	$V_R = 10$ V
	BA217				50			nA	$V_R = 10$ V
	BA218				200			nA	$V_R = 25$ V
	BA217				200			nA	$V_R = 30$ V
	BA218							nA	$V_R = 50$ V
						200		nA	$V_R = 50$ V
						500		nA	$V_R = 100$ V
C	Capacitance		3.0		3.0		5.0	pF	$V_R = 0, f = 1$ MHz
t_{rr}	Reverse Recovery Time		4.0		4.0			ns	$I_F = 10$ mA, $I_R = 60$ mA $R_L = 100 \Omega$ (Note 3)
						120		ns	$I_F = 30$ mA, $I_R = 30$ mA $R_L = 100 \Omega$ (Note 4)

NOTES:

1. These ratings are limiting values above which the serviceability of the diode may be impaired.
2. These are steady state limits. The factory should be consulted on applications involving pulsed or low duty-cycle operation.
3. Recovery to $I_F = 1$ mA.
4. Recovery to $I_F = 3$ mA.
5. For product family characteristic curves, refer to Chapter 4, D4

BA243 • BA244

BANDSWITCH DIODES

DIFFUSED SILICON PLANAR

- $R_S \dots 0.5 \Omega$ (MAX) BA244
- $C \dots 2 \text{ pF}$ (MAX)

ABSOLUTE MAXIMUM RATINGS (Note 1)

Temperatures

Storage Temperature Range	-65°C to +200°C
Maximum Junction Operating Temperature	+175°C
Lead Temperature	+260°C

Power Dissipation (Note 2)

Maximum Total Power Dissipation at 25°C Ambient	250 mW
Linear Power Derating Factor (from 25°C)	1.67 mW/°C

Maximum Voltage and Currents

WIV	Working Inverse Voltage	15 V
I_F	Continuous Forward Current	100 mA

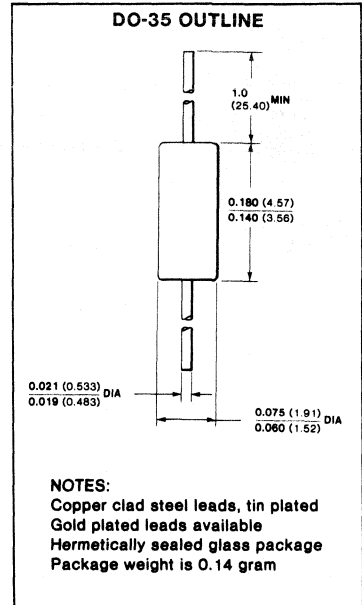

ELECTRICAL CHARACTERISTICS (25°C Ambient Temperature unless otherwise noted)

SYMBOL	CHARACTERISTIC	MIN	TYP	MAX	UNITS	TEST CONDITIONS
V_F	Forward Voltage		0.90	1.0	V	$I_F = 100 \text{ mA}$
I_R	Reverse Current		5.0 0.05	100 1.0	nA μA	$V_R = 15 \text{ V}$ $V_R = 15 \text{ V}, T_A = 60^\circ\text{C}$
BV	Breakdown Voltage	20			V	$I_R = 5.0 \mu\text{A}$
C	Capacitance		1.7	2.0	pF	$V_R = 15 \text{ V}, f = 1 \text{ MHz}$
$\frac{\Delta C}{C \cdot \Delta V_R}$	Capacitance Variation with Reverse Voltage		1.0		%/V	$V_R = 7 - 20 \text{ V}, f = 1 - 100 \text{ MHz}$, Relative to $V_R = 7 \text{ V}$
R_S	Series Resistance		0.70 0.40	1.0 0.50	Ω Ω	$I_f = 10 \text{ mA}, f = 1 - 100 \text{ MHz}$ $I_f = 10 \text{ mA}, f = 1 - 100 \text{ MHz}$

NOTES:

1. These ratings are limiting values above which the serviceability of the diode may be impaired.
2. These are steady state limits. The factory should be consulted on applications involving pulsed or low duty-cycle operation.
3. For product family characteristic curves, refer to Chapter 4, D7.

BB121A • BB121B • BB122

UHF, VHF / FM VARACTOR DIODES

DIFFUSED SILICON PLANAR

- C₃/C₂₅... 4.5-6.0
- MATCHED SETS (Note 2)

ABSOLUTE MAXIMUM RATINGS (Note 1)

Temperatures

Storage Temperature Range	-55°C to +150°C
Maximum Junction Operating Temperature	+150°C
Lead Temperature	+260°C

Maximum Voltage

WIV Working Inverse Voltage	30 V
-----------------------------	------

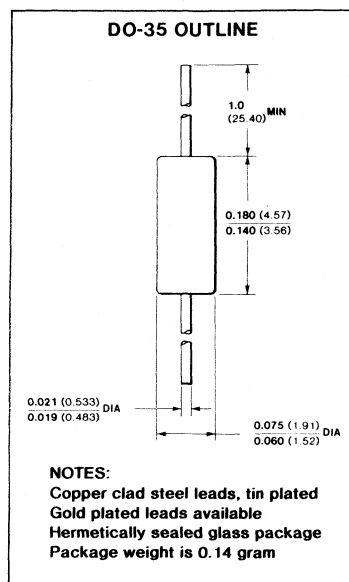

ELECTRICAL CHARACTERISTICS (25°C Ambient Temperature unless otherwise noted)

SYMBOL	CHARACTERISTIC	MIN	TYP	MAX	UNITS	TEST CONDITIONS	
BV	Breakdown Voltage	30			V	I _R = 100 μA	
I _R	Reverse Current		10	50	nA	V _R = 28 V	
C	Capacitance	BB 121A	17			pF	V _R = 1.0 V, f = 1 MHz
			11			pF	V _R = 3.0 V, f = 1 MHz
		BB 121B	2.00	2.20	2.35	pF	V _R = 25 V, f = 1 MHz
			18			pF	V _R = 1.0 V, f = 1 MHz
			12			pF	V _R = 3.0 V, f = 1 MHz
		BB 122	2.25	2.45	2.65	pF	V _R = 25 V, f = 1 MHz
			20			pF	V _R = 1.0 V, f = 1 MHz
		13			pF	V _R = 3.0 V, f = 1 MHz	
		2.10	2.45	2.80	pF	V _R = 25 V, f = 1 MHz	
C ₃ /C ₂₅	Capacitance Ratio	4.5	5.2	6.0		V _R = 3 V/25 V, f = 1 MHz	
R _S	Series Resistance	BB 121A/B	0.6	0.8	Ω	C = 9 pF, f = 470 MHz	
		BB 122	0.9	1.2	Ω	C = 9 pF, f = 470 MHz	
f _o	Series Resonant Frequency	BB 121A/B	2.0		GHz	V _R = 25 V	
		BB 122	1.8		GHz	V _R = 25 V	
L _S	Series Inductance		2.5		nH	1.5 mm from case	

NOTES:

1. These ratings are limiting values above which the serviceability of the diode may be impaired.
2. The capacitance difference between any two diodes in one set is less than 3% for the BB 121A and BB 121B and less than 6% for the BB 122 over the reverse voltage range of 0.5 V to 28 V.
3. For product family characteristic curves, refer to Chapter 4, D11.

BB139

VHF / FM VARACTOR DIODE

DIFFUSED SILICON PLANAR

- C₃/C₂₅ ... 5.0-6.5
- MATCHED SETS (Note 2)

ABSOLUTE MAXIMUM RATINGS (Note 1)

Temperatures

Storage Temperature Range	-55°C to +150°C
Maximum Junction Operating Temperature	+150°C
Lead Temperature	+260°C

Maximum Voltage

WIV Working Inverse Voltage	30 V
-----------------------------	------

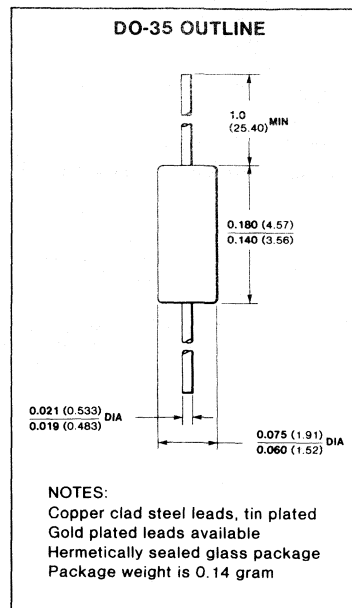

3

ELECTRICAL CHARACTERISTICS (25°C Ambient Temperature unless otherwise noted)

SYMBOL	CHARACTERISTIC	MIN	TYP	MAX	UNITS	TEST CONDITIONS
BV	Breakdown Voltage	30			V	I _R = 100 μA
I _R	Reverse Current		10 0.1	50 0.5	nA μA	V _R = 28 V V _R = 28 V, T _A = 60°C
C	Capacitance	4.3	29 5.1	6.0	pF pF	V _R = 3.0 V, f = 1 MHz V _R = 25 V, f = 1 MHz
C ₃ /C ₂₅	Capacitance Ratio	5.0	5.7	6.5		V _R = 3 V/25 V, f = 1 MHz
Q	Figure of Merit		150			V _R = 3.0 V, f = 100 MHz
R _S	Series Resistance		0.35		Ω	C = 10 pF, f = 600 MHz
L _S	Series Inductance		2.5		nH	1.5 mm from case
f _o	Series Resonant Frequency		1.4		GHz	V _R = 25 V

NOTES:

1. These ratings are limiting values above which the serviceability of the diode may be impaired.
2. The capacitance difference between any two diodes in one set is less than 3% over the reverse voltage range of 0.5 V to 28 V.
3. For product family characteristic curves, refer to Chapter 4, D12.

BB204B • BB204G • MV104

DUAL FM VARACTOR DIODES

DIFFUSED SILICON PLANAR

- C... 37–42 pF (BB204B, MV104)
- C... 34–39 pF (BB204G)
- Q... 100 (MIN) (MV104)

ABSOLUTE MAXIMUM RATINGS (Note 1)

Temperatures

Storage Temperature Range
Maximum Junction Operating Temperature
Lead Temperature

–55°C to +150°C
+150°C
+260°C

Power Dissipation (Note 2)

Maximum Total Power Dissipation at 25°C Ambient
Linear Power Derating Factor

280 mW
2.24 mW / °C

Maximum Voltage and Currents

WIV Working Inverse Voltage
IF Continuous Forward Current

30 V
200 mA

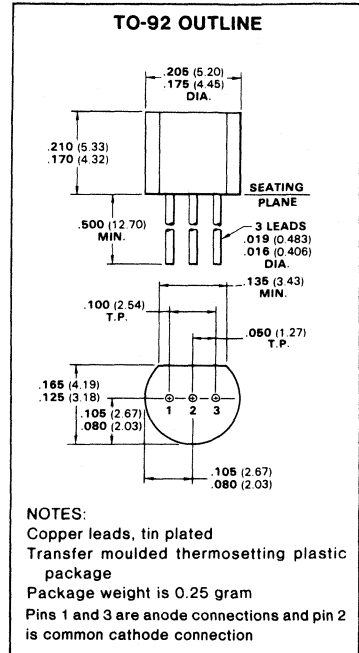

ELECTRICAL CHARACTERISTICS (25°C Ambient Temperature unless otherwise noted)

SYMBOL	CHARACTERISTIC (each diode)	MIN	TYP	MAX	UNITS	TEST CONDITIONS
BV	Breakdown Voltage	32				$I_R = 10 \mu A$
I_R	Reverse Current		5.0 50	50 500	nA nA	$V_R = 30 V$ $V_R = 30 V, T_A = 60^\circ C$
C	Capacitance	BB204B, MV104 BB204G	37 34	42 39	pF pF	$V_R = 3 V, f = 1 MHz$ $V_R = 3 V, f = 1 MHz$
C_3/C_{30}	Capacitance Ratio	BB204B, BB204G MV104	2.4 2.5	2.6 2.65	2.8 2.8	$V_R = 3 V, f = 1 MHz$ $V_R = 3 V, f = 1 MHz$
L_S	Series Inductance		6.0		nH	$f = 250 MHz, 1.5m/m leads$
R_D	Dynamic Resistance		0.2 0.2	0.4	Ω Ω	$V_R @ 38 pF, f = 100 MHz$ $V_R @ 38 pF, f = 100 MHz$
C_C	Case Capacitance		0.18		pF	$f = 1 MHz, 1.5m/m leads$
TC_C	Capacitance Temperature Coefficient		280	400	ppm / °C	
Q	Figure of Merit	MV104	100	125		$V_R = 3 V, f = 100 MHz$

NOTES:

1. These ratings are limiting values above which the serviceability of the diode may be impaired.
2. These are steady state limits. The factory should be consulted on applications involving pulsed or low duty-cycle operation.
3. For product family characteristic curves, refer to Chapter 4, D9.

BZX55C3V3 – BZX55C33

500 mW SILICON ZENER DIODES

ABSOLUTE MAXIMUM RATINGS (Note 1)

Temperatures

Storage Temperature Range	-65°C to +200°C
Maximum Junction Operating Temperature	+200°C
Lead Temperature	+260°C

Power Dissipation (Note 2)

Maximum Total Power Dissipation at 25°C Ambient	500 mW
Linear Power Derating Factor (from 25°C)	2.85 mW / °C
Maximum Surge Power (Note 4)	30 W

DO-35 OUTLINE

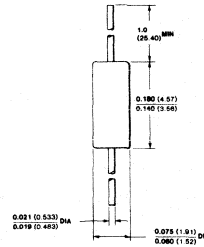

NOTES:

- Copper clad steel leads, tin plated
- Gold plated leads available
- Hermetically sealed glass package
- Package weight is 0.14 gram

3

ELECTRICAL CHARACTERISTICS (25°C Ambient)

SYMBOL	V _Z		Z _Z	Z _{ZK}	I _R	V _{RT}	I _{ZM}	TC
	Zener Voltage (Note 3)		Maximum Zener Impedance	Maximum Zener Knee Impedance	Maximum Reverse Current	Test Voltage	Maximum Zener Current	
	MIN	MAX	@I _Z =5.0 mA	@I _{ZK} =1.0 mA	@V _{RT} 150°C			
UNIT	V	V	Ω	Ω	μA	V	μA	% / °C
BZX55C3V3	3.1	3.5	85	600	40	1.0	115	-0.060
BZX55C3V6	3.4	3.8	85	600	40	1.0	108	-0.055
BZX55C3V9	3.7	4.1	80	600	40	1.0	100	-0.050
BZX55C4V3	4.0	4.6	70	600	40	1.5	90	-0.040
BZX55C4V7	4.4	5.0	60	600	30	1.5	85	-0.020
BZX55C5V1	4.8	5.4	35	550	2.0	1.0	79	+0.010
BZX55C5V6	5.2	6.0	25	450	2.0	1.0	74	+0.025
BZX55C6V2	5.8	6.6	10	200	2.0	2.0	69	+0.032
BZX55C6V8	6.4	7.2	8.0	150	2.0	3.0	64	+0.040
BZX55C7V5	7.0	7.9	7.0	50	2.0	5.0	59	+0.045
BZX55C8V2	7.7	8.7	7.0	50	2.0	6.0	54	+0.048
BZX55C9V1	8.5	9.6	10	50	2.0	7.0	49	+0.050
BZX55C10	9.4	10.6	15	70	2.0	7.5	44	+0.055
BZX55C11	10.4	11.6	20	70	2.0	8.5	40	+0.060
BZX55C12	11.4	12.7	20	90	2.0	9.0	36	+0.065
BZX55C13	12.4	14.1	26	110	2.0	10	32	+0.070
BZX55C15	13.8	15.6	30	110	2.0	11	30	+0.070
BZX55C16	15.3	17.1	40	170	2.0	12	27	+0.075
BZX55C18	16.8	19.1	50	170	2.0	14	24	+0.075
BZX55C20	18.8	21.2	55	220	2.0	15	22	+0.080
BZX55C22	20.8	23.3	55	220	2.0	17	20	+0.080
BZX55C24	22.8	25.6	80	220	2.0	18	18	+0.085
BZX55C27	25.1	28.9	80	220	2.0	20	16	+0.085
BZX55C30	28.0	32.0	80	220	2.0	22	15	+0.085
BZX55C33	31.0	35.0	80	220	2.0	24	13	+0.085

NOTES:

- These ratings are limiting values above which the serviceability of the diode may be impaired.
- These are steady state limits. The factory should be consulted on application involving pulsed or low duty-cycle operation.
- ±20%, ±10%, ±2% and ±1% V_Z tolerance versions are available.
- Non-recurrent square wave, PW = 100 μs, T_J = 150°C.
- V_F = 1.0 V (max) @ I_F = 100 mA for all types.
- For product family characteristic curves, refer to Chapter 4, D13.

BZY88C3V3 – BZY88C33

500 mW SILICON ZENER DIODES

ABSOLUTE MAXIMUM RATINGS (Note 1)

Temperatures

Storage Temperature Range	-65°C to +200°C
Maximum Junction Operating Temperature	+200°C
Lead Temperature	+260°C

Power Dissipation (Note 2)

Maximum Total Power Dissipation at 25°C Ambient	500 mW
Linear Power Derating Factor (from 25°C)	2.85 mW/°C
Maximum Surge Power (Note 3)	15 W

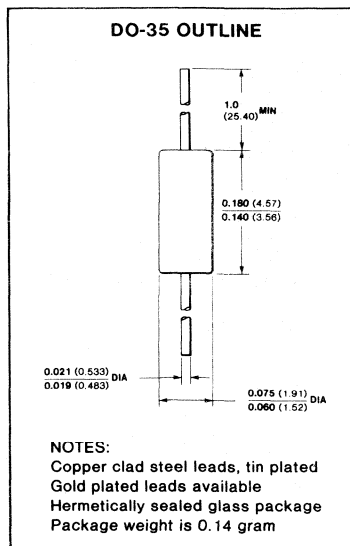

ELECTRICAL CHARACTERISTICS (AT $I_Z=1.0$ mA, 25°C Ambient)

SYMBOL	V _Z			Z _Z	TC		
	Zener Voltage			Maximum Zener Impedance	Temperature Coefficient of V _Z		
	MIN	NOM	MAX		MIN	TYP	MAX
UNIT	V	V	V	Ω	mV/°C	mV/°C	mV/°C
BZY88C3V3	2.4	2.75	3.0	440	-4.5	-1.9	-0.5
BZY88C3V6	2.7	3.0	3.3	430	-4.5	-2.05	-0.5
BZY88C3V9	3.0	3.3	3.6	430	-3.5	-2.4	-0.5
BZY88C4V3	3.3	3.6	3.9	430	-2.7	-2.25	-0.5
BZY88C4V7	3.7	4.1	4.3	420	-2.5	-2.0	-0.3
BZY88C5V1	4.3	4.65	5.0	370	-2.1	-1.9	-0.3
BZY88C5V6	4.8	5.3	5.7	350	-1.8	-1.4	0
BZY88C6V2	5.7	5.9	6.5	250	0	+1.6	+3.0
BZY88C6V8	6.3	6.7	6.9	70	+2	+3.2	+3.7
BZY88C7V5	7.0	7.45	7.8	20	+3	+4.2	+5.9
BZY88C8V2	7.8	8.1	8.5	20	+4.3	+5.0	+6.0
BZY88C9V1	8.55	9.0	9.5	24	+4.5	+6.0	+7.0
BZY88C10	9.3	9.9	10.5	50	+6.0	+6.6	+7.0
BZY88C11	10.3	10.9	11.5	70	+7.1	+8.3	+9.0
BZY88C12	11.3	11.9	12.5	80	+7.6	+8.7	+9.2
BZY88C13	12.3	12.9	13.0	90	+9.1	+10.1	+11.1
BZY88C15	13.8	14.9	15.5	95	+11	+12.5	+13
BZY88C16	15.3	15.8	16.9	100	+12	+13	+14
BZY88C18	16.7	17.8	18.9	120	+14	+15	+16.5
BZY88C20	18.7	19.8	21.0	140	+16	+17	+18.5
BZY88C22	20.6	21.8	23.1	150	+17	+19	+21
BZY88C24	22.5	23.8	25.7	200	+19	+21	+23
BZY88C27	24.7	26.6	28.5	300	+21	+22.5	+25
BZY88C30	27.5	29.5	31.5	350	+22	+24	+29
BZY88C33	29.5	32.0	34.5	450	+23	+25	+35

NOTES:

- These ratings are limiting values above which the serviceability of the diode may be impaired.
- These are steady state limits. The factory should be consulted on applications involving pulsed or low duty-cycle operation.
- Non-recurrent square wave, PW = 100 μs, T_J = 150°C
- V_F = 0.9 V (Max) @ I_F = 10 mA for all types
- For Product Family Characteristic curves, refer to Chapter 4, D13

FAIRCHILD • BZY88C3V3 – BZY88C33

ELECTRICAL CHARACTERISTICS (AT $I_z = 5.0$ mA 25°C Ambient)

SYMBOL	V _Z			Z _Z	TC			
	Zener Voltage				Maximum Zener Impedance	Temperature Coefficient of V _Z		
	MIN	NOM	MAX			MIN	TYP	MAX
UNIT	V	V	V	Ω	mV/°C	mV/°C	mV/°C	
BZY88C3V3	3.1	3.3	3.5	110	-4.0	-2.3	-0.5	
BZY88C3V6	3.4	3.6	3.8	105	-3.5	-2.0	-0.5	
BZY88C3V9	3.7	3.9	4.1	100	-2.5	-2.05	-0.5	
BZY88C4V3	4.0	4.3	4.5	90	-2.5	-1.8	-0.5	
BZY88C4V7	4.4	4.7	5.0	85	-2.0	-1.55	0	
BZY88C5V1	4.8	5.1	5.4	75	-1.75	-1.2	0	
BZY88C5V6	5.3	5.6	6.0	55	-1.5	-0.2	+1.0	
BZY88C6V2	5.8	6.2	6.6	27	+0.5	+2.0	+3.5	
BZY88C6V8	6.4	6.8	7.2	15	+2.3	+3.2	+3.8	
BZY88C7V5	7.1	7.5	7.9	15	+3.1	+4.2	+5.9	
BZY88C8V2	7.8	8.2	8.7	20	+4.2	+5.0	+6.0	
BZY88C9V1	8.6	9.1	9.6	25	+4.8	+6.0	+7.0	
BZY88C10	9.4	10	10.6	25	+6.0	+7.0	+7.5	
BZY88C11	10.4	11	11.6	25	+7.0	+8.7	+9.1	
BZY88C12	11.4	12	12.6	35	+8.5	+9.0	+9.6	
BZY88C13	12.4	13	14.1	35	+10	+10.5	+11.5	
BZY88C15	13.9	15	15.6	35	+12	+12.5	+14	
BZY88C16	15.4	16	17.1	40	+12	+13	+14	
BZY88C18	16.9	18	19.1	45	+14	+15	+18	
BZY88C20	18.9	20	21.2	50	+16	+17	+19	
BZY88C22	20.8	22	23.3	60	+17	+19	+21	
BZY88C24	22.7	24	25.9	75	+20	+21	+24	
BZY88C27	25.1	27	28.9	85	+22	+23.5	+27	
BZY88C30	28	30	32	95	+25	+26	+29	
BZY88C33	31	33	35	120	+27	+28	+36	

ELECTRICAL CHARACTERISTICS (AT $I_z = 20$ mA 25°C Ambient)

SYMBOL	V _Z			Z _Z	TC			
	Zener Voltage				Maximum Zener Impedance	Temperature Coefficient of V _Z		
	MIN	NOM	MAX			MIN	TYP	MAX
UNIT	V	V	V	Ω	mV/°C	mV/°C	mV/°C	
BZY88C3V3	3.5	4	4.2	22	-3.3	-2.4	-0.5	
BZY88C3V6	3.9	4.2	4.4	20	-2.5	-1.55	-0.5	
BZY88C3V9	4.2	4.45	4.65	18	-2.4	-1.55	-0.5	
BZY88C4V3	4.45	4.7	4.95	17	-2.0	-1.5	-0.5	
BZY88C4V7	4.9	5.1	5.3	17	-1.5	-0.85	0	
BZY88C5V1	5.1	5.35	5.7	11	-1.5	-0.8	0	
BZY88C5V6	5.45	5.75	6.1	8.0	-1.0	+1.0	+3.0	
BZY88C6V2	5.95	6.4	6.7	3.1	+1.0	+2.2	+4.0	
BZY88C6V8	6.6	6.9	7.25	3.0	+2.8	+3.2	+3.8	
BZY88C7V5	7.2	7.65	7.95	5.0	+2.5	+4.2	+5.9	
BZY88C8V2	7.9	8.4	8.75	6.0	+4.0	+5.0	+6.0	
BZY88C9V1	8.7	9.4	9.7	7.0	+5.0	+6.0	+7.0	
BZY88C10	9.5	10.1	10.8	8.0	+7.0	+7.3	+7.5	
BZY88C11	10.5	11.1	11.8	10	+8.5	+9.1	+9.5	
BZY88C12	11.6	12.2	12.8	25	+8.9	+9.6	+10.3	
BZY88C13	12.6	13.2	14.3	25	+11	+11.5	+12.5	
BZY88C15	14.1	15.3	15.9	25	+12	+13.5	+14.5	
BZY88C16	15.6	16.3	17.4	30	+13	+14	+15	
BZY88C18	17.2	18.4	19.6	30	+15	+16	+18	
BZY88C20	19.3	20.5	21.9	35	+17.5	+18.5	+20.5	
BZY88C22	21.3	22.6	24.1	35	+19	+20.5	+22.5	
BZY88C24	23.3	24.7	26.7	40	+20	+23	+25	
BZY88C27	25.8	28.1	30.1	45	+23	+25.5	+28	
BZY88C30	29.0	31.3	33.4	50	+25	+28	+32	
BZY88C33	32.0	34.2	36.6	60	+27	+30	+38	

FAIRCHILD • BZY88C3V3 – BZY88C33

ELECTRICAL CHARACTERISTICS (25°C Ambient)

SYMBOL	C	I _R	V _{RT}
CHARACTERISTIC	Typical Capacitance @V _R = 3.0 V	Maximum Reverse Current @V _{RT}	Test Voltage
UNIT	pF	μA	V
BZY88C3V3	395	3.0	1
BZY88C3V6	370	3.0	1
BZY88C3V9	335	3.0	1
BZY88C4V3	270	3.0	1
BZY88C4V7	290	3.0	2
BZY88C5V1	275	1.0	2
BZY88C5V6	260	1.0	2
BZY88C6V2	240	1.0	2
BZY88C6V8	220	1.0	3
BZY88C7V5	190	0.5	3
BZY88C8V2	150	0.4	3
BZY88C9V1	140	0.4	5
BZY88C10	110	2.5	7
BZY88C11	90	2.5	7
BZY88C12	80	2.5	8
BZY88C13	65	2.5	9
BZY88C15	60	2.5	10
BZY88C16	55	2.5	10
BZY88C18	50	2.5	13
BZY88C20	45	2.5	14
BZY88C22	43	2.5	15
BZY88C24	42	2.5	17
BZY88C27	40	2.5	19
BZY88C30	35	2.5	21
BZY88C33	35	2.5	23

3

FA SERIES

PAIR, QUAD AND BRIDGE DIODE ASSEMBLIES

SILICON PLANAR EPITAXIAL

- ΔV_F ... Down to 3 mV (MAX)
- ΔI_R ... Down to 10 nA (MAX)

GENERAL DESCRIPTION

The FA series of diode assemblies are pairs, quads and bridges composed of individual glass diodes encapsulated in epoxy packages. The pairs and quads are also available in unencapsulated form, the diodes being securely taped together for shipment.

These assemblies feature very tight matching characteristics over broad temperature and current ranges.

ABSOLUTE MAXIMUM RATINGS (Note 1)

Temperatures

Storage Temperature Range	-65°C to +200°C
Maximum Junction Operating Temperature	+175°C
Lead Temperature	+260°C

Power Dissipation (Note 2)

Maximum Total Power Dissipation at 25°C Ambient	
Each Diode	250 mW
Encapsulated Package	500 mW
Linear Power Derating factor (from 25°C)	
Each Diode	1.67 mW/°C
Encapsulated Package	3.33 mW/°C

Maximum Voltage and Currents

Basic Diode (See Specification below)	FD1389	FD2389	FD3389	FD6389
V _{WV} Working Inverse Voltage	75 V	150 V	125 V	50 V
I _O Average Rectified Current	100 mA	100 mA	150 mA	200 mA
I _F Continuous Forward Current	150 mA	150 mA	225 mA	300 mA
i _f Recurrent Peak Forward Current	300 mA	300 mA	450 mA	600 mA
i _{f(surge)} Peak Forward Surge Current				
Pulse width = 1.0 s	1.0 A	1.0 A	1.0 A	1.0 A
Pulse width = 1.0 μs	4.0 A	4.0 A	4.0 A	4.0 A

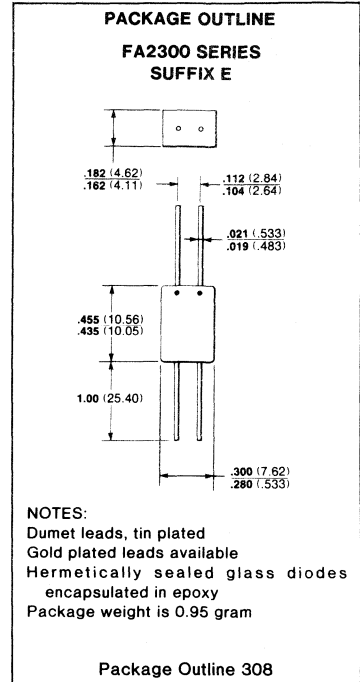

MATCHING CHARACTERISTICS (Apply over temperature range of -55°C to +100°C)

Basic Diode (See Specification below)	Forward Current Matching Range (Notes 4 & 6)	Reverse Current Match (ΔI_R Maximum) (Note 3)	Forward Voltage Match (ΔV_F Maximum)	Assembly Type Number				
				Encapsulated Pair	Unencapsulated Pair	Encapsulated Quad	Unencapsulated Quad	Bridge (Note 6)
FD1389	10 μA to 1.0 mA		3.0 mV	FA2310E	FA2310U	FA4310E	FA4310U	FA3310
FD1389	10 μA to 1.0 mA		10 mV	FA2311E	FA2311U	FA4311E	FA4311U	FA3311
FD1389	1.0 mA to 10 mA		5.0 mV	FA2312E	FA2312U	FA4312E	FA4312U	FA3312
FD1389	1.0 mA to 10 mA		15 mV	FA2313E	FA2313U	FA4313E	FA4313U	FA3313
FD2389	10 μA to 1.0 mA		3.0 mV	FA2320E	FA2320U	FA4320E	FA4320U	FA3320
FD2389	10 μA to 1.0 mA		10 mV	FA2321E	FA4321U	FA4321E	FA4321U	FA3321
FD2389	1.0 mA to 10 mA		5.0 mV	FA2322E	FA2322U	FA4322E	FA4322U	FA3322
FD2389	1.0 mA to 10 mA		15 mV	FA2323E	FA2323U	FA4323E	FA4323U	FA3323
FD2389	10 mA to 100 mA		10 mV	FA2324E	FA2324U	FA4324E	FA4324U	FA3324
FD2389	10 mA to 100 mA		20 mV	FA2325E	FA2325U	FA4325E	FA4325U	FA3325
FD3389	10 μA to 1.0 mA	(2.0 + 0.064 V _R) nA	10 mV	FA2330E	FA2330U	FA4330E	FA4330U	FA3330
FD3389	1.0 mA to 10 mA	(2.0 + 0.064 V _R) nA	15 mV	FA2331E	FA2331U	FA4331E	FA4331U	FA3331
FD3389	10 mA to 100 mA	(2.0 + 0.064 V _R) nA	20 mV	FA2332E	FA2332U	FA4332E	FA4332U	FA3332
FD3389	10 μA to 1.0 mA	(4.0 + 0.128 V _R) nA	10 mV	FA2333E	FA2333U	FA4333E	FA4333U	FA3333
FD3389	1.0 mA to 10 mA	(4.0 + 0.128 V _R) nA	15 mV	FA2334E	FA2334U	FA4334E	FA4334U	FA3334
FD3389	10 mA to 100 mA	(4.0 + 0.128 V _R) nA	20 mV	FA2335E	FA2335U	FA4335E	FA4335U	FA3335
FD6389	10 mA to 100 mA		10 mV	FA2360E	FA2360U	FA4360E	FA4360U	FA3360
FD6389	10 mA to 100 mA		20 mV	FA2361E	FA2361U	FA4361E	FA4361U	FA3361

FAIRCHILD • FA SERIES

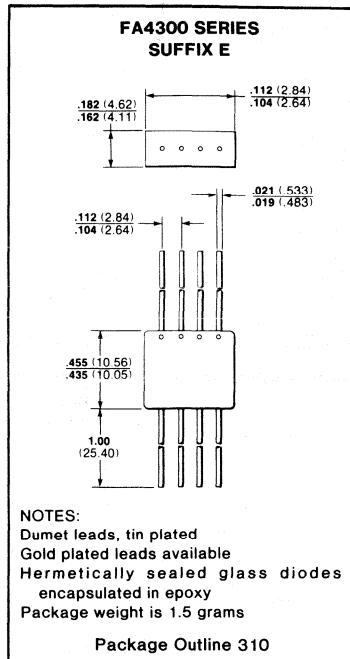
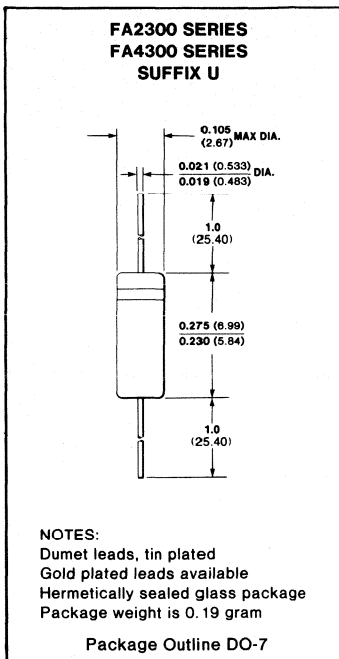
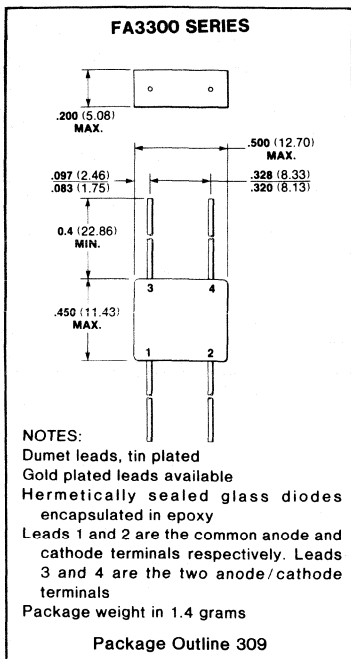

3

BASIC DIODE ELECTRICAL CHARACTERISTICS (25°C Ambient Temperature unless otherwise noted)

SYMBOL	CHARACTERISTIC	FD1389		FD2389		FD3389		FD6389		UNITS	TEST CONDITIONS
		MIN	MAX	MIN	MAX	MIN	MAX	MIN	MAX		
BV	Breakdown Voltage	100		200		150		75		V V	$I_R = 5.0 \mu A$ $I_R = 100 \mu A$
I_R	Reverse Current		100 100		100 100		1.0 3.0		100 100	nA μA	$V_R = WIV$ $V_R = WIV, T_A = 150^\circ C$
V_F	Forward Voltage				1.000 0.925 0.860 0.790 0.875 0.800 0.725 0.670		1.000 0.930 0.880 0.840 0.750 0.770 0.730 0.710		1.000 0.920 0.860 0.790 0.750 0.710 0.670 0.630	V V V V V V V V	$I_F = 200 \text{ mA}$ $I_F = 100 \text{ mA}$ $I_F = 50 \text{ mA}$ $I_F = 20 \text{ mA}$ $I_F = 10 \text{ mA}$ $I_F = 5.0 \text{ mA}$ $I_F = 2.0 \text{ mA}$ $I_F = 1.0 \text{ mA}$
C	Capacitance (Note 5)		2.0		5.0		6.0		3.0	pF	$V_R = 0, f = 1 \text{ MHz}$
t_{rr}	Reverse Recovery Time		4.0		50				4.0	ns ns ns	$I_F = I_R = 10 \text{ mA}$ Recover to 1.0 mA $I_F = I_R = 30 \text{ mA}$ Recover to 1.0 mA $I_F = I_R = 200 \text{ mA}$ Recover to 20 mA

- NOTES:**
- These are Limiting values above which life or satisfactory performance may be impaired
 - These are steady state Limits. The factory should be consulted on applications involving pulsed or low duty-cycle operation.
 - The Reverse Current Match (ΔI_R) is the difference in reverse current between the diode having the highest I_R and that having the lowest I_R in a given assembly. The reverse voltage (V_R) in the ΔI_R calculation can be any value up to 125 V. For example, the maximum ΔI_R for an FA2330E at V_R of 10 V is $(2.0 + 0.064 \times 10) \text{ nA}$ or 2.64 nA.
 - The Forward Current Matching Ranges between 10 μA and 10 mA may be applied either as a dc current or a pulse current. Above 10 mA, however, the matching characteristics are guaranteed only for low duty cycle ($\leq 1\%$) pulse current. Conditions of test are shown in the characteristic curve and test circuit section of this book (see Note 7).
 - Capacitance cannot be monitored independently on each diode in a bridge configuration. In measuring capacitance in a bridge, the limit is 4/3 that shown in the basic diode electrical characteristics.
 - For matched bridges, the forward current range specified is per leg. Therefore, twice the current specified is applied to the assembly.
 - For product family characteristics curves for the basic diodes used in the assemblies, refer to the following parts of Section 4.

- FD1389 D4
- FD2389 D1
- FD3389 D2
- FD6389 D4

For test circuits, refer to Chapter 4, D18.

FDH300•FDH333

HIGH CONDUCTANCE LOW LEAKAGE DIODES

DIFFUSED SILICON PLANAR

- $V_F \dots 150 \text{ V (MIN) @ } 100 \mu\text{A}$
- $I_R \dots 1.0 \text{ nA (MAX) @ } 125 \text{ V (FDH300), } 3.0 \text{ nA (MAX) @ } 125 \text{ V (FDH333)}$

ABSOLUTE MAXIMUM RATINGS (Note 1)

Temperatures

Storage Temperature Range	-65°C to +200°C
Maximum Junction Operating Temperature	+175°C
Lead Temperature	+260°C

Power Dissipation (Note 2)

Maximum Total Dissipation at 25°C Ambient	500 mW
Linear Derating Factor (from 25°C)	3.33 mW/°C

Maximum Voltages and Currents

WIV	Working Inverse Voltage	125 V
I_O	Average Rectified Current	200 mA
I_F	Forward Current Steady State	500 mA
i_f	Recurrent Peak Forward Current	600 mA
$i_f(\text{surge})$	Peak Forward Surge Current	600 mA
	Pulse Width = 1.0 s	1.0 A
	Pulse Width = 1.0 μs	4.0 A

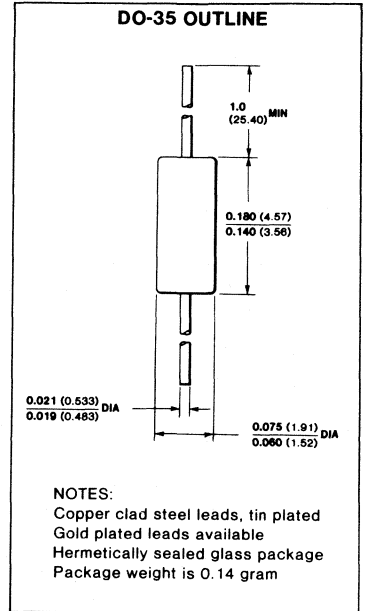

ELECTRICAL CHARACTERISTICS (25°C Ambient Temperature unless otherwise noted)

SYMBOL	CHARACTERISTIC	FDH300		FDH333		UNITS	TEST CONDITIONS
		MIN	MAX	MIN	MAX		
V_F	Forward Voltage			0.9	1.15	V	$I_F = 300 \text{ mA}$
				0.88	1.08	V	$I_F = 250 \text{ mA}$
			1.0	0.87	1.05	V	$I_F = 200 \text{ mA}$
				0.86	0.97	V	$I_F = 150 \text{ mA}$
			0.92	0.83	0.94	V	$I_F = 100 \text{ mA}$
			0.88	0.80	0.89	V	$I_F = 50 \text{ mA}$
			0.8			V	$I_F = 10 \text{ mA}$
			0.75			V	$I_F = 5.0 \text{ mA}$
			0.68			V	$I_F = 1.0 \text{ mA}$
		I_R	Reverse Current		1.0		3.0
	3.0					μA	$V_R = 125 \text{ V, } T_A = 150^\circ\text{C}$
					500	nA	$V_R = 125 \text{ V, } T_A = 100^\circ\text{C}$
C	Capacitance		6.0		6.0	pF	$V_R = 0, f = 1 \text{ MHz}$
BV	Breakdown Voltage	150		150		V	$I_R = 100 \mu\text{A}$

NOTES:

1. The maximum ratings are limiting values above which life or satisfactory performance may be impaired.
2. These are steady state limits. The factory should be consulted on applications involving pulsed or low duty cycle operations.
3. For family characteristic curves, refer to Chapter 4, D2.

FDH400 • FDH444

HIGH VOLTAGE GENERAL PURPOSE DIODES

DIFFUSED SILICON PLANAR

- BV ... 200 V (MIN) FDH400
... 150 V (MIN) FDH444
- VF ... 1.1 V (MAX) @ 300 mA FDH400
@ 200 mA FDH444

ABSOLUTE MAXIMUM RATINGS (Note 1)

Temperatures

Storage Temperature Range	-65°C to +200°C
Max Junction Operating Temperature	+175°C
Lead Temperature	+260°C

Power Dissipation (Note 2)

Maximum Total Dissipation at 25°C Ambient	500 mW
Linear Derating Factor (from 25°C)	3.33 mW/°C

Maximum Voltage and Currents

		FDH400	FDH444
WIV	Working Inverse Voltage	175 V	125 V
I _O	Average Rectified Current	200 mA	200 mA
I _F	Forward Current Steady State	500 mA	500 mA
i _F	Recurrent Peak Forward Current	600 mA	600 mA
i _{F(surge)}	Peak Forward Surge Current		
	Pulse width = 1.0 s	1.0 A	1.0 A
	Pulse width = 1.0 μs	4.0 A	4.0 A

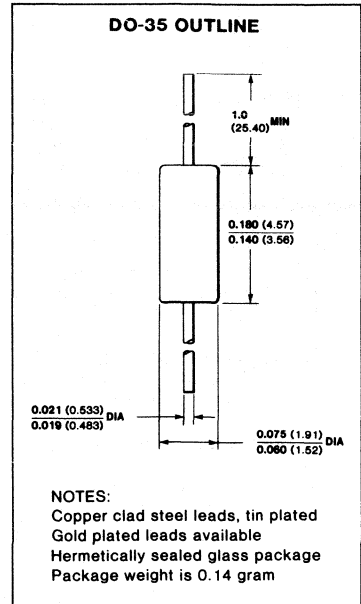

3

ELECTRICAL CHARACTERISTICS (25°C Ambient Temperature unless otherwise noted)

SYMBOL	CHARACTERISTIC	FDH400		FDH444		UNITS	TEST CONDITIONS
		MIN	MAX	MIN	MAX		
VF	Forward Voltage		1.1		1.2	V	I _F = 300 mA
			1.0		1.1	V	I _F = 200 mA
BV	Breakdown Voltage	200		150		V	I _R = 100 μA
I _R	Reverse Current		100		50	nA	V _R = 150 V
			100		100	nA	V _R = 100 V
						μA	V _R = 150 V, T _A = 150°C
						μA	V _R = 100 V, T _A = 150°C
C	Capacitance		2.0		2.5	pF	V _R = 0, f = 1.0 MHz
t _{rr}	Reverse Recovery Time		50		60	ns	I _F = 30 mA, I _r = 30 mA R _L = 100 Ω, I _r = 3.0 mA

NOTES:

1. The maximum ratings are limiting values above which life or satisfactory performance may be impaired.
2. These are steady state limits. The factory should be consulted on applications involving pulsed or low duty cycle operations.
3. For product family characteristic curves, refer to Chapter 4, D1.

FDH600 • FDH666

ULTRA FAST DIODES

DIFFUSED SILICON PLANAR EPITAXIAL

- C ... 2.5 pF (MAX) FDH600, 3.5 pF (MAX) FDH666
- V_F ... 1.0 V (MAX) @ 100 mA (FDH666)
... 1.0 V (MAX) @ 200 mA (FDH600)
- t_{rr} ... 4.0 ns (MAX) @ I_f = I_r = 10 mA

ABSOLUTE MAXIMUM RATINGS (Note 1)

Temperatures

Storage Temperature Range	-65°C to +200°C
Maximum Junction Operating Temperature	+175°C
Lead Temperature	+260°C

Power Dissipation (Note 2)

Maximum Total Dissipation at 25°C Ambient	500 mW
Linear Derating Factor (from 25°C)	3.33 mW/°C

Maximum Voltage and Currents

	FDH 600	FDH 666
WIV Working Inverse Voltage	50 V	25 V
I _O Average Rectified Current	200 mA	200 mA
I _F Continuous Forward Current	500 mA	500 mA
i _f Recurrent Peak Forward Current	600 mA	600 mA
i _f (surge) Peak Forward Surge Current		
Pulse Width = 1.0 s	1.0 A	1.0 A
Pulse Width = 1.0 μs	4.0 A	4.0 A

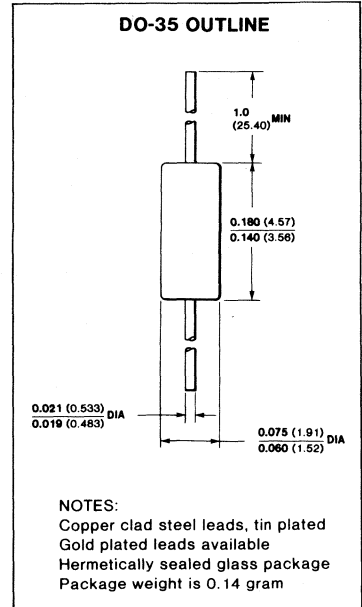

ELECTRICAL CHARACTERISTICS (25°C Ambient Temperature unless otherwise noted)

SYMBOL	CHARACTERISTIC	FDH600		FDH666		UNITS	TEST CONDITIONS
		MIN	MAX	MIN	MAX		
V _F	Forward Voltage		1.0			V	I _F = 200 mA
			0.92		1.0	V	I _F = 100 mA
			0.86		0.86	V	I _F = 50 mA
			0.79		0.79	V	I _F = 10 mA
			0.65		0.65	V	I _F = 1.0 mA
I _R	Reverse Current		0.1			μA	V _R = 50 V
					0.1	μA	V _R = 25 V
			100			μA	V _R = 50 V, T _A = 150°C
					100	μA	V _R = 25 V, T _A = 150°C
BV	Breakdown Voltage	75		40		V	I _R = 5.0 μA
t _{rr}	Reverse Recovery Time (Note 3)		4.0		4.0	ns	I _f = I _r = 10 mA, R _L = 100 Ω
			6.0		6.0	ns	I _f = I _r = 200 mA, R _L = 100 Ω
C	Capacitance		2.5		3.5	pF	V _R = 0, f = 1.0 MHz

NOTES:

1. The maximum ratings are limiting values above which life or satisfactory performance may be impaired.
2. These are steady state limits. The factory should be consulted on applications involving pulsed or low duty-cycle operation.
3. Recovery to 0.1 I_R.
4. For product family characteristic curves, refer to Chapter 4, D4.

FDH900 • FDH999

HIGH SPEED SWITCHING DIODES

DIFFUSED SILICON PLANAR

- BV... 45 V (FDH900), 35 V (FDH999)
- t_{rr} ... 4.0 ns (FDH900), 5.0 ns (FDH999)

ABSOLUTE MAXIMUM RATINGS (Note 1)

Temperatures

Storage Temperature Range	-65°C to +200°C
Max. Junction Operating Temperature	+175°C
Lead Temperature	+260°C

Power Dissipation (Note 2)

Maximum Total Dissipation at 25°C Ambient	500 mW
Linear Derating Factor (From 25°C)	3.3 mW/°C

Maximum Voltage and Currents

WIV	Working Inverse Voltage	FDH900	40 V
		FDH999	25 V
I_O	Average Rectified Current		200 mA
I_F	Continuous Forward Current		500 mA
i_f	Recurrent Peak Forward Current		600 mA
$i_f(\text{surge})$	Peak Forward Surge Current		600 mA
	Pulse Width = 1.0 s		1.0 A
	Pulse Width = 1.0 μ s		4.0 A

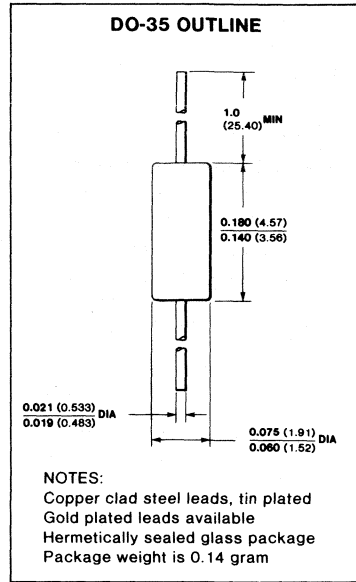

3

ELECTRICAL CHARACTERISTICS (25°C Ambient Temperature unless otherwise noted)

SYMBOL	CHARACTERISTIC	FDH900		FDH999		UNITS	TEST CONDITIONS
		MIN	MAX	MIN	MAX		
BV	Breakdown Voltage	45		35		V	$I_R = 5.0 \mu A$
I_R	Reverse Current		500		1.0	μA nA	$V_R = 25 V$ $V_R = 40 V$
V_F	Forward Voltage		1.0		1.0	V V	$I_F = 10 mA$ $I_F = 100 mA$
C	Capacitance		3.0		5.0	pF	$V_R = 0, f = 1.0 MHz$
t_{rr}	Reverse Recovery Time		4.0		5.0	ns	$I_f = 10 mA, I_r = 10 mA,$ $R_L = 100 \Omega, I_{rr} = 1.0 mA$

NOTES:

1. These ratings are limiting values above which the serviceability of any individual semiconductor device may be impaired.
2. These are steady state limits. The factory should be consulted on applications involving pulsed or low duty-cycle operation.
3. For product family characteristic curves, refer to Chapter 4, D4.

FDH1000

HIGH CONDUCTANCE SWITCHING DIODE

DIFFUSED SILICON PLANAR

- V_F ... 1 V (MAX) @ 500 mA
- Q_S ... 100 pC (MAX)

ABSOLUTE MAXIMUM RATINGS (Note 1)

Temperatures

Storage Temperature Range	-65°C to +200°C
Maximum Junction Operating Temperature	+175°C
Lead Temperature	+260°C

Power Dissipation (Note 2)

Maximum Total Power Dissipation at 25°C Ambient	500 mW
Linear Power Derating Factor	3.33 mW/°C

Maximum Voltage and Currents

WIV	Working Inverse Voltage	50 V
I_O	Average Rectified Current	200 mA
I_F	Continuous Forward Current	500 mA
I_f	Peak Repetitive Forward Current	600 mA
$I_f(\text{surge})$	Peak Forward Surge Current	
	Pulse Width = 1 s	1.0 A
	Pulse Width = 1 μ s	4.0 A

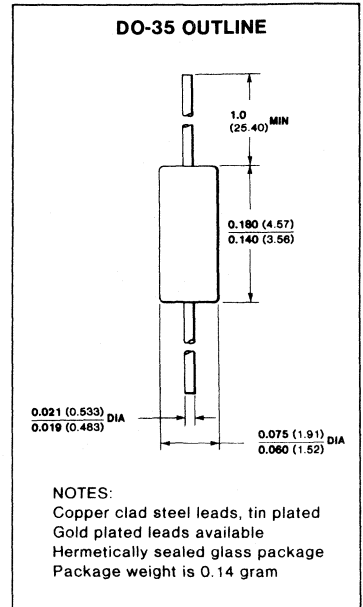

ELECTRICAL CHARACTERISTICS (25°C Ambient Temperature unless otherwise noted)

SYMBOL	CHARACTERISTIC	MIN	MAX	UNITS	TEST CONDITIONS
V_f	Forward Voltage		1.0	V	$I_F = 500$ mA
I_R	Reverse Current		5.0 50 50	μ A nA μ A	$V_R = 50$ V $V_R = 20$ V $V_R = 20$ V, $T_A = 125^\circ$ C
BV	Breakdown Voltage	75		V	$I_R = 100$ μ A
C	Capacitance		5.0	pF	$V_R = 0$, $f = 1.0$ MHz
Q_S	Stored Charge		100	pC	$I_f = 10$ mA, $V_R = 10$ V

NOTES:

1. These ratings are limiting values above which the serviceability of the diode may be impaired.
2. These are steady state limits. The factory should be consulted on applications involving pulsed or low duty-cycle operation.

FD700 • FD777

PICOSECOND COMPUTER DIODES

DIFFUSED SILICON PLANAR

- C... 1.0 pF (MAX) @ $V_R = 0$, $f = 1.0$ MHz (FD 700)
- t_{rr} ... 700 ps (MAX) @ $I_f = I_r = 10$ mA, $R_L = 100 \Omega$ (FD 700)
- CONTROLLED FORWARD CONDUCTANCE

ABSOLUTE MAXIMUM RATINGS (Note 1)

Temperatures	FD700	FD777
Storage Temperature Range	-65°C to +200°C	-65°C to +200°C
Max Junction Operating Temperature	+175°C	+175°C
Lead Temperature	+260°C	+260°C
Power Dissipation		
Maximum Total Dissipation at 25°C		
Ambient	250 mW	250 mW
Linear Derating Factor (from 25°C)	1.67 mW/°C	1.67 mW/°C
Maximum Voltages and Currents		
WIV Working Inverse Voltage	20 V	8.0 V
I_O Average Rectified Current	50 mA	50 mA
I_F Forward Current Steady State dc	150 mA	150 mA
i_f Recurrent Peak Forward Current	150 mA	150 mA
i_f (surge) Peak Forward Surge Current		
Pulse Width = 1.0 s	250 mA	250 mA

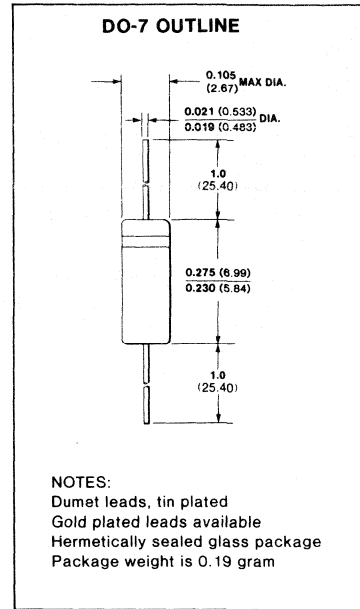

3

ELECTRICAL CHARACTERISTICS (25°C Ambient Temperature unless otherwise noted)

SYMBOL	CHARACTERISTIC	FD700		FD777		UNITS	TEST CONDITIONS
		MIN	MAX	MIN	MAX		
V_F	Forward Voltage	0.89	1.10	0.89	1.35	V	$I_F = 50$ mA
		0.81	0.95	0.81	1.00	V	$I_F = 20$ mA
		0.76	0.88	0.76	0.94	V	$I_F = 10$ mA
		0.64	0.74	0.64	0.79	V	$I_F = 1.0$ mA
		0.52	0.61	0.52	0.64	V	$I_F = 0.1$ mA
		0.42	0.50	0.42	0.53	V	$I_F = 0.01$ mA
BV	Breakdown Voltage	30		15		V	$I_R = 5.0 \mu A$
I_R	Reverse Current		50		100	nA	$V_R = 20$ V
			50			nA	$V_R = 8.0$ V
					50	μA	$V_R = 20$ V, $T_A = 150^\circ C$
						μA	$V_R = 8.0$ V, $T_A = 150^\circ C$
τ	Minority Carrier Lifetime		450		450	ps	(see Note 2)
t_{rr}	Reverse Recovery Time (Note 3)		700		750	ps	$I_f = I_r = 10$ mA, $R_L = 100 \Omega$
C	Capacitance		1.0		1.3	pF	$V_R = 0$, $f = 1.0$ MHz

- NOTES:
1. The maximum ratings are limiting values above which life or satisfactory performance may be impaired.
 2. Measured as suggested by S. M. Krakauer, IRE Proceedings, Volume 60, July 1962, pp. 1674 - 1675.
 3. Recovery to 0.1 I_R .
 4. For product family characteristic curves, refer to Chapter 4, D3.

FH1100 • 1N5390

HOT CARRIER DIODE

DIFFUSED SILICON

- Q_S ... 1.6 pC (TYP)
- C ... 1.0 pF (MAX)
- NF ... 10 dB (MAX) @ $f = 890$ MHz

ABSOLUTE MAXIMUM RATINGS (Note 2)

Temperatures

Storage Temperature Range
 Max Junction Operating Temperature
 Lead Temperature

-65°C to +150°C
 +125°C
 +260°C

Power Dissipation (Note 3)

Maximum Total Dissipation at 25°C Ambient
 Linear Derating Factor (from 25°C)

100 mW
 1.0 mW / °C

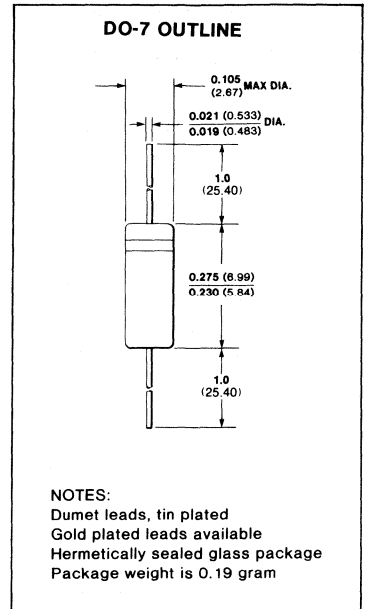

ELECTRICAL CHARACTERISTICS (25°C Ambient Temperature unless otherwise noted)

SYMBOL	CHARACTERISTIC	MIN	TYP	MAX	UNITS	TEST CONDITIONS
V_F	Forward Voltage			0.55	V	$I_F = 10$ mA
I_R	Leakage Current			1.0 50	μ A nA	$V_R = 1.0$ V $V_R = 1.0$ V
BV	Breakdown Voltage	5.0			V	$I_R = 100$ μ A
C	Capacitance			1.0	pF	$V_R = 0$, $f = 1.0$ MHz
NF	Noise Figure			10	dB	$f = 890$ MHz
Q_S	Stored Charge (Note 1)		1.6	3.0	pC pC	$I_F = 10$ mA $I_F = 10$ mA

NOTES:

1. Measured on B-Line Electronics QS-3 stored charge meter.
2. The maximum ratings are limiting values above which life or satisfactory performance may be impaired.
3. These are steady state limits. The factory should be consulted on applications involving pulsed or low duty-cycle operation.
4. For product family characteristic curves, refer to Chapter 4, D10.

FJT1100 • FJT1101

ULTRA LOW LEAKAGE

DIFFUSED SILICON PLANAR DIODES

- I_R ... 1.0 pA (MAX) @ 5 V (FJT1100)
- BV ... 20 V (MIN) (FJT1100)

ABSOLUTE MAXIMUM RATINGS (Note 1)

Temperature

Storage Temperature Range	-55°C to +200°C
Maximum Junction Operating Temperature	+175°C
Lead Temperature	+260°C

Power Dissipation (Note 2)

Maximum Total Power Dissipation at 25°C Ambient	250 mW
Linear Power Derating factor (from 25°C)	1.67 mW/°C

Maximum Voltage and Current

WIV	Working Inverse Voltage	FJT1100	25 V
I_f	Continuous Forward Current	FJT1101	15 V 150 mA

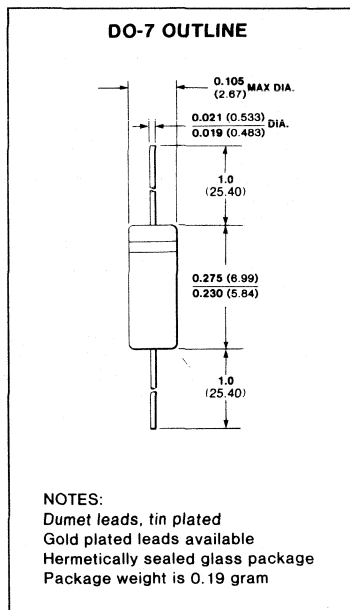

3

ELECTRICAL CHARACTERISTICS (25°C Ambient Temperature unless otherwise noted)

SYMBOL	CHARACTERISTIC		MIN	MAX	UNITS	TEST CONDITIONS
BV	Breakdown Voltage	FJT1100	30		V	$I_R = 5.0 \mu A$
		FJT1101	20		V	$I_R = 5.0 \mu A$
I_R	Reverse Current	FJT1100		1.0	pA	$V_R = 5.0 V$
				10	pA	$V_R = 15 V$
		FJT1101		5.0	pA	$V_R = 5.0 V$
				15	pA	$V_R = 15 V$
V_F	Forward Voltage	FJT1100		1.05	V	$I_F = 50 mA$
		FJT1101		1.10	V	$I_F = 50 mA$
C	Capacitance	FJT1100		1.5	pF	$V_R = 0, f = 1 MHz$
		FJT1101		1.8	pF	$V_R = 0, f = 1 MHz$

NOTES:

1. These are limiting values above which the serviceability of the diode may be impaired.
2. These are steady state limits. The factory should be consulted on applications involving pulsed or low duty-cycle operation.
3. For product family characteristic curves and applications information, refer to Chapter 4, D6.

FSA1410M • FSA1411M • FSA2002M • FSA2003M

PLANAR AIR-ISOLATED MONOLITHIC DIODE ARRAYS*

- C...5.0 pF (MAX)
- ΔV_F ...15 mV (MAX) @ 10 mA

ABSOLUTE MAXIMUM RATINGS (Note 1)

Temperatures

Storage Temperature Range
Maximum Junction Operating Temperature
Lead Temperature

-55°C to +200°C
+150°C
+260°C

Power Dissipation (Note 2)

Maximum Dissipation per Junction at 25°C Ambient
per Package at 25°C Ambient
Linear Derating Factor (from 25°C) Junction
Package

400 mW
600 mW
3.2 mW/°C
.4.8 mW/°C

Maximum Voltage and Currents

WIV Working Inverse Voltage
I_F Continuous Forward Current
I_F(surge) Peak Forward Surge Current
Pulse Width=1.0 s
Pulse Width=1.0 μs

55 V
350 mA
1.0 A
2.0 A

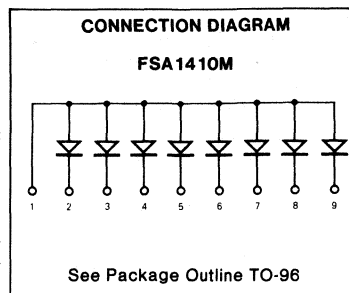

ELECTRICAL CHARACTERISTICS (25°C Ambient Temperature unless otherwise noted)

SYMBOL	CHARACTERISTIC	MIN	MAX	UNITS	TEST CONDITIONS
B _V	Breakdown Voltage	60		V	I _R = 10 μA
V _F	Forward Voltage (Note 3)		1.5 1.1 1.0	V V V	I _F = 500 mA I _F = 200 mA I _F = 100 mA
I _R	Reverse Current Reverse Current (T _A = 150°C)		100 100	nA μA	V _R = 40 V V _R = 40 V
C	Capacitance		5.0	pF	V _R = 0, f = 1 MHz
V _{FM}	Peak Forward Voltage		4.0	V	I _F = 500 mA, t _r < 10 ns
t _{fr}	Forward Recovery Time		40	ns	I _F = 500 mA, t _r < 10 ns
t _{rr}	Reverse Recovery Time		10 50	ns ns	I _F = I _r = 10–200 mA R _L = 100 Ω, Rec. to 0.1 I _r I _F = 500 mA, I _r = 50 mA R _L = 100 Ω, Rec. to 5 mA
ΔV _F	Forward Voltage Match		15	mV	I _F = 10 mA

NOTES:

1. These ratings are limiting values above which life or satisfactory performance may be impaired.
2. These are steady state limits. The factory should be consulted on applications involving pulsed or low duty cycle operation.
3. V_F is measured using an 8 ms pulse.
4. For product family characteristic curves and test circuits, refer to Chapter 4, D15.

*8 COMMON CATHODE, 8 COMMON ANODE

FAIRCHILD • DIODE ARRAYS

FSA1411M

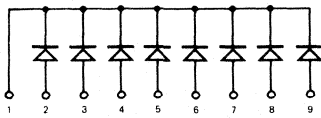

See Package Outline TO-96

FSA2002M

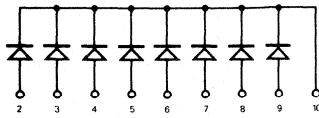

See Package Outline TO-85

FSA2003M

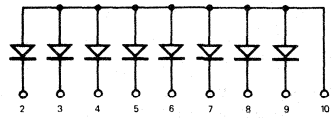

See Package Outline TO-85

TO-96 OUTLINE

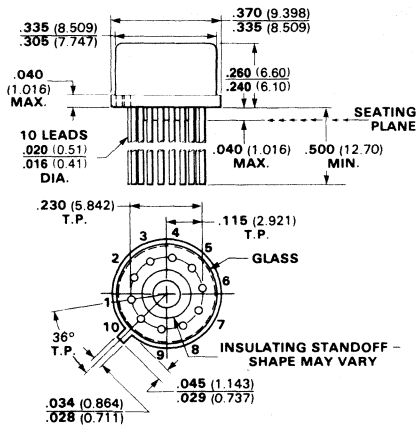

NOTES:
 Kovar leads, gold plated
 Hermetically sealed package
 Package weight is 1.32 grams

TO-85 OUTLINE

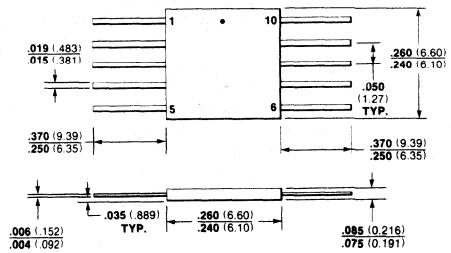

NOTES:
 Alloy 42 leads, tin plated
 Gold plated leads available
 Hermetically sealed ceramic package
 Dot or tab indicates lead 1
 Package weight is 0.26 gram

FSA2500M • FSA2501M • FSA2501P • FSA2502M

PLANAR AIR-ISOLATED MONOLITHIC DIODE ARRAYS*

- C ... 5.0 pF (MAX)
- V_F ... 15 mV (MAX) @ 10 mA

ABSOLUTE MAXIMUM RATINGS (Note 1)

Temperatures

Storage Temperature Range (M Suffix)	-55° C to +200° C
(P, Suffix)	-55° C to +150° C
Maximum Junction Operating Temperature	+150° C
Lead Temperature	+260° C

Power Dissipation (Note 2)

Maximum Dissipation per Junction at 25° C Ambient	400 mW
Maximum Dissipation per Package at 25° C Ambient	650 mW
Linear Derating Factor (from 25° C) Junction	3.2 mW / ° C
Package	5.2 mW / ° C

Maximum Voltage and Currents

WIV	Working Inverse Voltage	50 V
I _F	Continuous Forward Current	350 mA
i _f (surge)	Peak Forward Surge Current	
	Pulse Width = 1.0 s	1.0 A
	Pulse width = 1.0 μs	2.0 A

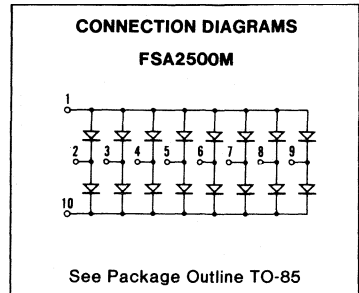

ELECTRICAL CHARACTERISTICS (25° C Ambient Temperature unless otherwise noted)

SYMBOL	CHARACTERISTIC	MIN	MAX	UNITS	TEST CONDITIONS
BV	Breakdown Voltage	60		V	I _R = 10 μA
V _F	Forward Voltage (Note 3)		1.0 1.1 1.5	V V V	I _F = 100 mA I _F = 200 mA I _F = 500 mA
ΔV _F	Forward Voltage Match (Note 3)		15	mV	I _F = 10 mA
I _R	Reverse Current (Note 4)		100 200	nA μA	V _R = 50 V V _R = 50 V, T _A = 125° C
C	Capacitance (Note 5)		5.0	pF	V _R = 0, f = 1.0 MHz
t _{fr}	Forward Recovery Time (Note 6)		40	ns	I _F = 500 mA
t _{rr}	Reverse Recovery Time (Note 6)		10 50	ns ns	I _F = I _r = 10 mA to 200 mA R _L = 100 Ω, I _{rr} = 0.1 I _R I _F = 500 mA, I _r = 50 mA R _L = 100 Ω, I _{rr} = 5.0 mA

NOTES:

1. These ratings are limiting values above which life or satisfactory performance may be impaired.
2. These are steady state limits. The factory should be consulted on applications involving pulsed or low duty-cycle operation.
3. V_F is measured using an 8 ms pulse.
4. See test circuits (Note 6) for measurement of reverse current of an individual diode.
5. The capacitance is measured from pin-to-pin across any one of the diodes. The interaction of other diodes is therefore included in the measured value.
6. For product family characteristic curves and test circuits refer to Chapter 4, D15.

* 16-DIODE CORE DRIVER MATRIX

FAIRCHILD • DIODE ARRAYS

FSA2501M • FSA2501P

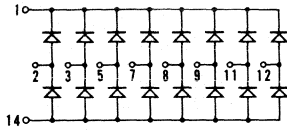

See Package Outlines

TO-116-2 (Ceramic) FSA2501M
 TO-116 (Plastic) FSA2501P

FSA2502M

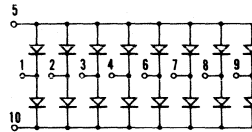

See Package Outline TO-96

TO-85 OUTLINE

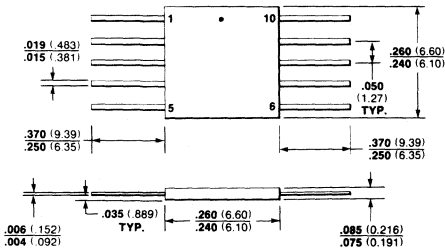

NOTES:
 Alloy 42 leads, tin plated
 Gold plated leads available
 Hermetically sealed ceramic package
 Dot or tab indicates lead 1
 Package weight is 0.26 gram

TO-116-2 OUTLINE

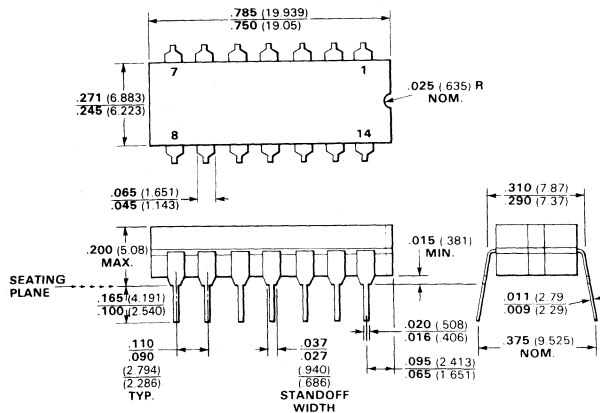

NOTES:
 Alloy 42 pins, tin plated
 Gold plated pins available
 Hermetically sealed ceramic package
 Pins are intended for insertion in hole rows on .300" (7.620) centers
 They are purposely shipped with "positive" misalignment to facilitate insertion
 Board-drilling dimensions should equal your practice for .020" (0.508) diameter pin
 Package weight is 2.0 grams

FAIRCHILD • DIODE ARRAYS

TO-96 OUTLINE

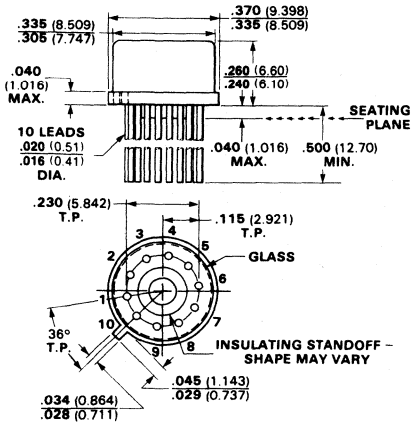

NOTES:

- Kovar leads, gold plated
- Hermetically sealed package
- Package weight is 1.32 grams

TO-116 OUTLINE

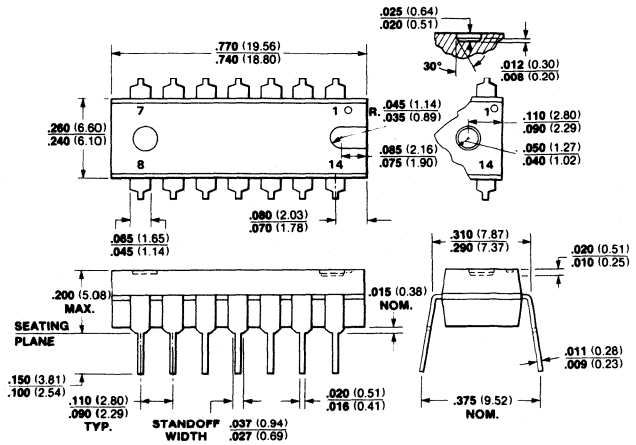

NOTES:

- Alloy 42 pins, tin plated
- Gold plated pins available
- Transfer moulded DM-6B plastic package
- Pins are intended for insertion in hole rows on .300" (7.62) centers
- They are purposely shipped with "positive" misalignment to facilitate insertion
- Board drilling dimensions should equal your practice for .020 (0.508) inch diameter pin
- Package weight is 0.9 gram

FSA2503M • FSA2503P • FSA2504M

PLANAR AIR-ISOLATED MONOLITHIC DIODE ARRAYS

- C... 5.0 pF (MAX)
- ΔF... 15 mV (MAX) @ 10 mA

ABSOLUTE MAXIMUM RATINGS (Note 1)

Temperatures

Storage Temperature Range (M Suffix)	-55°C to +200°C
(P Suffix)	-55°C to +150°C
Maximum Junction Operating Temperature	+150°C
Lead Temperature	+260°C

Power Dissipation (Note 2)

Maximum Dissipation per Junction at 25°C Ambient	400 mW
Maximum Dissipation per Package at 25°C Ambient	650 mW
Linear Derating Factor (from 25°C) Junction	3.2 mW/°C
Package	5.2 mW/°C

Maximum Voltage and Currents

WIV	Working Inverse Voltage	50 V
I _F	Continuous Forward Current	350 mA
i _f (surge)	Peak Forward Surge Current	
	Pulse Width=1.0 s	1.0 A
	Pulse Width=1.0 μs	2.0 A

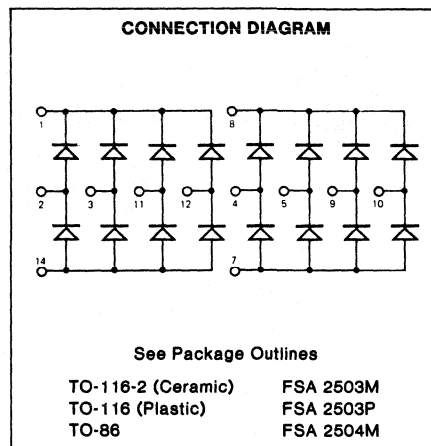

3

ELECTRICAL CHARACTERISTICS (25°C Ambient Temperature unless otherwise noted)

SYMBOL	CHARACTERISTIC	MIN	MAX	UNITS	TEST CONDITIONS
BV	Breakdown Voltage	60		V	I _R = 10 μA
V _F	Forward Voltage (Note 3)		1.0 1.1 1.5	V	I _F = 100 mA I _F = 200 mA I _F = 500 mA
ΔV _F	Forward Voltage Match (Note 6)		15	mV	I _F = 10 mA
I _R	Reverse Current (Note 4)		100 200	nA μA	V _R = 50 V V _R = 50 V, T _A = 125°C
C	Capacitance (Note 5)		5.0	pF	V _R = 0, f=1.0 MHz
t _{fr}	Forward Recovery Time (Note 6)		40	ns	I _f = 500 mA
t _{rr}	Reverse Recovery Time (Note 6)		10 50	ns	I _f = I _r = 10 mA to 200 mA R _L = 100 Ω, I _{rr} = 0.1 I _R I _f = 500 mA, I _r = 50 mA R _L = 100 Ω, I _{rr} = 5.0 mA

NOTES:

1. These ratings are limiting values above which life or satisfactory performance may be impaired.
2. These are steady state limits. The factory should be consulted on applications involving pulsed or low duty-cycle operation.
3. V_F is measured using an 8 ms pulse.
4. See test circuits (Note 6) for measurement of reverse current of an individual diode.
5. The capacitance is measured from pin-to-pin across any one of the diodes. The interaction of other diodes is therefore included in the measured value.
6. For product family characteristics and test circuits, refer to Chapter 4, D15.

*DUAL 8-DIODE CORE DRIVER MATRIX

FAIRCHILD • DIODE ARRAYS

TO-116-2 OUTLINE

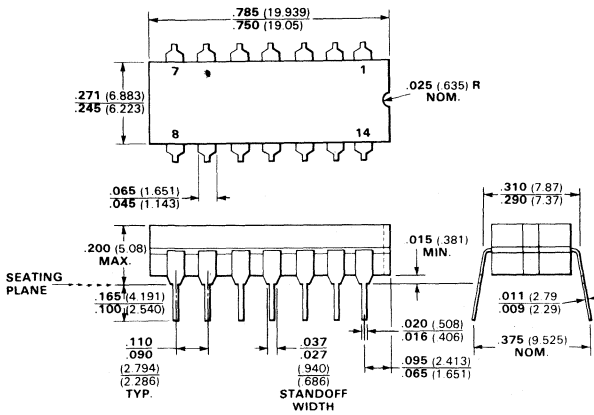

- NOTES:**
- Alloy 42 pins, tin plated
 - Gold plated pins available
 - Hermetically sealed ceramic package
 - Pins are intended for insertion in hole rows on .300" (7.620) centers
 - They are purposely shipped with "positive" misalignment to facilitate insertion
 - Board-drilling dimensions should equal your practice for .020" (0.508) diameter pin
 - Package weight is 2.0 grams

TO-86 OUTLINE

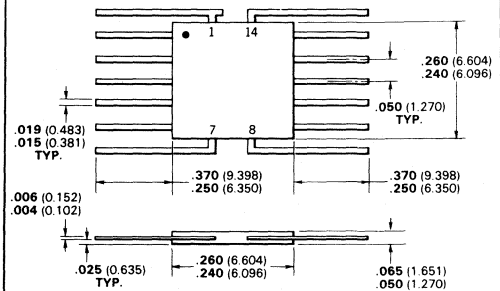

- NOTES:**
- Alloy 42 leads, tin plated
 - Gold plated leads available
 - Hermetically sealed ceramic package
 - Dot or tab indicates lead 1
 - Package weight is 0.27 gram

TO-116 OUTLINE

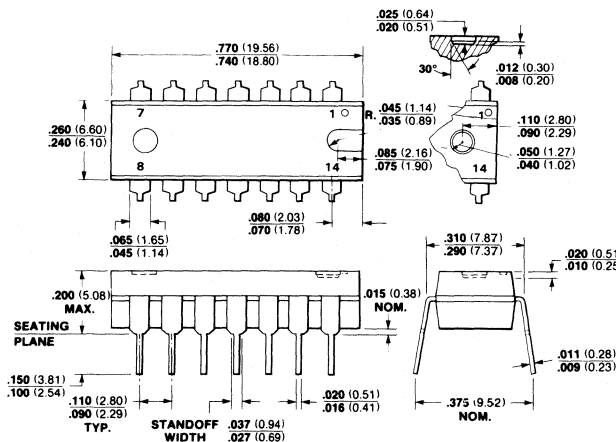

- NOTES:**
- Alloy 42 pins, tin plated
 - Gold plated pins available
 - Transfer moulded DM-6B plastic package
 - Pins are intended for insertion in hole rows on .300" (7.62) centers
 - They are purposely shipped with "positive" misalignment to facilitate insertion
 - Board drilling dimensions should equal your practice for .020 (0.508) inch diameter pin
 - Package weight is 0.9 gram

FSA2509M • FSA2509P • FSA2510M • FSA2510P

PLANAR AIR-ISOLATED MONOLITHIC DIODE ARRAYS*

- C ... 5.0 pF (MAX)
- ΔV_F ... 15 mV (MAX) @ 10 mA

ABSOLUTE MAXIMUM RATINGS (Note 1)

Temperatures

Storage Temperature Range (M Suffix)
(P Suffix)

-55°C to +200°C
-55°C to +150°C
+150°C
+260°C

Maximum Junction Operating Temperature
Lead Temperature

Power Dissipation (Note 2)

Maximum Dissipation per Junction at 25°C Ambient
Maximum Dissipation per Package at 25°C Ambient
Linear Derating factor (from 25°C) Junction
Package

400 mW
650 mW
3.2 mW/°C
5.2 mW/°C

Maximum Voltage and Currents

WIV Working Inverse Voltage
 I_F Continuous Forward Current
 $i_{f(\text{surge})}$ Peak Forward Surge Current
Pulse Width = 1.0 s
Pulse Width = 1.0 μ s

40 V
350 mA
1.0 A
2.0 A

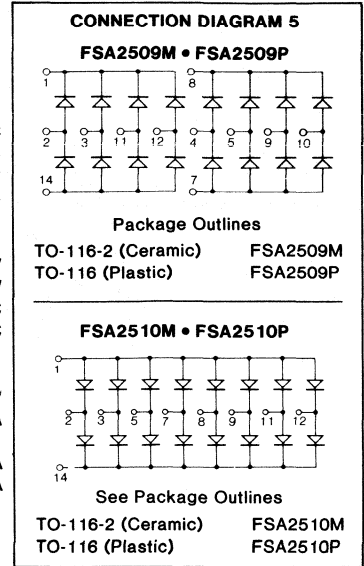

3

ELECTRICAL CHARACTERISTICS (25°C Ambient Temperature unless otherwise noted)

SYMBOL	CHARACTERISTIC	MIN	MAX	UNITS	TEST CONDITIONS
BV	Breakdown Voltage	60		V	$I_R = 10 \mu\text{A}$
V_F	Forward Voltage (Note 3)		1.0 1.1 1.3	V V V	$I_F = 100 \text{ mA}$ $I_F = 200 \text{ mA}$ $I_F = 500 \text{ mA}$
ΔV_F	Forward Voltage Match (Note 6)		15	mV	$I_F = 10 \text{ mA}$
I_R	Reverse Current (Note 4)		100 200	nA μA	$V_R = 40 \text{ V}$ $V_R = 40 \text{ V}, T_A = 150^\circ\text{C}$
C	Capacitance (Note 5)		5.0	pF	$V_R = 0, f = 1.0 \text{ MHz}$
t_{fr}	Forward Recovery Time (Note 6)		40	ns	$I_f = 500 \text{ mA}$
t_{rr}	Reverse Recovery Time (Note 6)		10 50	ns ns	$I_f = I_r = 10 \text{ mA to } 200 \text{ mA}$ $R_L = 100 \Omega, I_{rr} = 0.1 I_R$ $I_f = 500 \text{ mA}, I_r = 50 \text{ mA}$ $R_L = 100 \Omega, I_{rr} = 5.0 \text{ mA}$

NOTES:

1. These ratings are limiting values above which life or satisfactory performance may be impaired.
2. These are steady state limits. The factory should be consulted on applications involving pulsed or low duty-cycle operation.
3. V_F is measured using an 8 ms pulse.
4. See test circuits (Note 6) for measurement of reverse current of an individual diode.
5. The capacitance is measured from pin-to-pin across any one of the diodes. The interaction of other diodes is therefore included in the measured value.
6. For product family characteristic curves and test circuits, refer to Chapter 4, D15.

*DUAL 8-DIODE AND 16-DIODE CORE DRIVER MATRICES

FAIRCHILD • DIODE ARRAYS

TO-116-2 OUTLINE

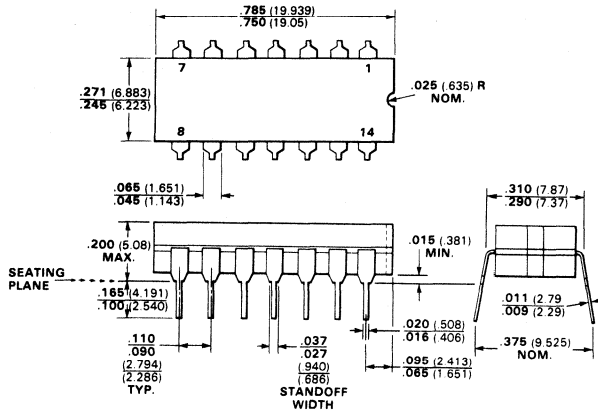

NOTES:

- Alloy 42 pins, tin plated
- Gold plated pins available
- Hermetically sealed ceramic package
- Pins are intended for insertion in hole rows on $.300$ " (7.620) centers
- They are purposely shipped with "positive" misalignment to facilitate insertion
- Board-drilling dimensions should equal your practice for $.020$ " (0.508) diameter pin
- Package weight is 2.0 grams

TO-116 OUTLINE

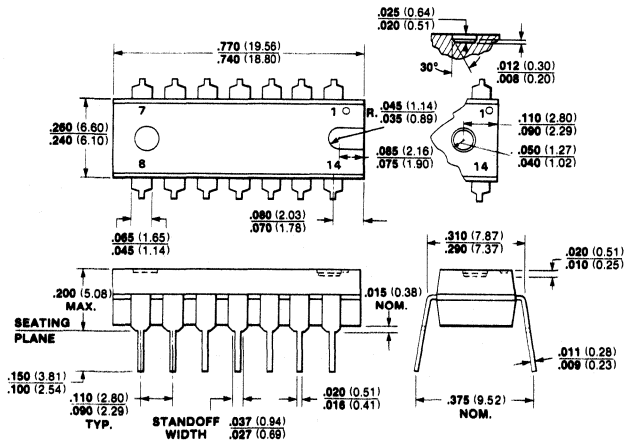

NOTES:

- Alloy 42 pins, tin plated
- Gold plated pins available
- Transfer moulded DM-6B plastic package
- Pins are intended for insertion in hole rows on $.300$ " (7.62) centers
- They are purposely shipped with "positive" misalignment to facilitate insertion
- Board drilling dimensions should equal your practice for $.020$ (0.508) inch diameter pin
- Package weight is 0.9 gram

FSA2563M • FSA2563P • FSA2564M • FSA2564P FSA2565M • FSA2565P • FSA2566M • FSA2566P

PLANAR AIR-ISOLATED MONOLITHIC DIODE ARRAYS

- C... 3.0 pf (max)
- V_F... 15 mV (max) @ 10 mA

ABSOLUTE MAXIMUM RATINGS (Note 1)

Temperatures

Storage Temperature Range (M Suffix)	-55°C to +200°C
(P Suffix)	-55°C to +150°C
Maximum Junction Operating Temperature	+150°C
Lead Temperature	+260°C

Power Dissipation (Note 2)

Maximum Dissipation per Junction at 25°C Ambient	400 mW
Maximum Dissipation per Package at 25°C Ambient	650 mW
Linear Derating Factor (from 25°C) Junction	3.2 mW / °C
Package	5.2 mW / °C

Maximum Voltage and Currents

WIV	Working Inverse Voltage	40 V
I _F	Continuous Forward Current	350 mA
i _f (surge)	Peak Forward Surge Current	
	Pulse Width = 1.0 s	1.0 A
	Pulse Width = 1.0 μs	2.0 A

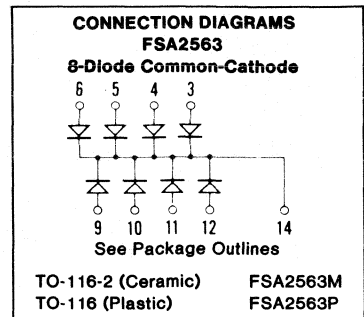

ELECTRICAL CHARACTERISTICS (25°C Ambient Temperature unless otherwise noted)

SYMBOL	CHARACTERISTIC	MIN	MAX	UNITS	TEST CONDITIONS
BV	Breakdown Voltage	60		V	I _R = 10 μA
V _F	Forward Voltage (Note 3)		1.0 1.1 1.3	V V V	I _F = 100 mA I _F = 200 mA I _F = 500 mA
I _R	Reverse Current (Note 4)		100 100	nA μA	V _R = 40 V V _R = 40 V, T _A = 125°C
C	Capacitance (Note 5)		3	pF	V _R = 0 V, f = 1 MHz
V _{FM}	Peak Forward Voltage (Note 6)		4	V	I _F = 500 mA
t _{fr}	Forward Recovery Time (Note 6)		40	ns	I _F = 500 mA
t _{rr}	Reverse Recovery Time (Note 6)		10 50	ns ns	I _F = I _r = 10 mA to 200 mA R _L = 100Ω, I _{rr} = 0.1 I _r I _F = 500 mA, I _r = 50 mA R _L = 100Ω, I _{rr} = 5 mA
ΔV _F	Forward Voltage Match (Note 6)		15	mV	I _F = 10 mA

NOTES:

1. These ratings are limiting values above which life or satisfactory performance may be impaired.
2. These are steady state limits. The factory should be consulted on applications involving pulsed or low duty-cycle operation.
3. V_F is measured using an 8 μs pulse.
4. See test circuits (Note 6) for measurement of reverse current of an individual diode.
5. The capacitance is measured from pin-to-pin across any one of the diodes. The interaction of other diodes is therefore included in the measured value.
6. For product family characteristic curves and test circuits, refer to Chapter 4, D15.

*COMMON ANODE, COMMON CATHODE

FAIRCHILD • DIODE ARRAYS

FSA2564
8-Diode Common-Anode

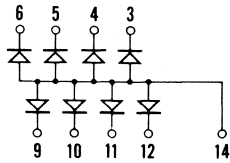

See Package Outlines

TO-116-2 (Ceramic) FSA2564M
TO-116 (Plastic) FSA2564P

FSA2565
13-Diode Common-Cathode

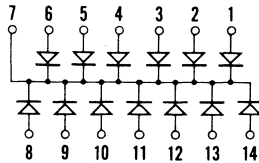

See Package Outlines

6B (Ceramic DIP) FSA2565M
9B (Plastic DIP) FSA2565P

FSA2566
13-Diode Common-Anode

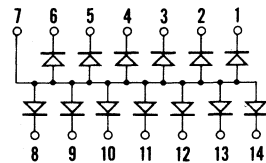

See Package Outlines

6B (Ceramic DIP) FSA2566M
9B (Plastic DIP) FSA2566P

TO-116-2 OUTLINE

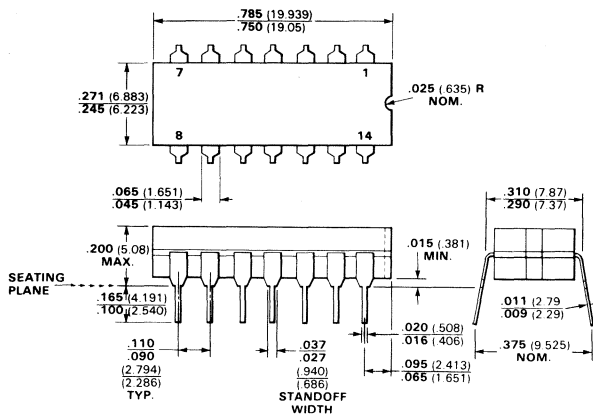

NOTES:

- Alloy 42 pins, tin plated
- Gold plated pins available
- Hermetically sealed ceramic package
- Pins are intended for insertion in hole rows on .300" (7.620) centers
- They are purposely shipped with "positive" misalignment to facilitate insertion
- Board-drilling dimensions should equal your practice for .020" (0.508) diameter pin
- Package weight is 2.0 grams

TO-116 OUTLINE

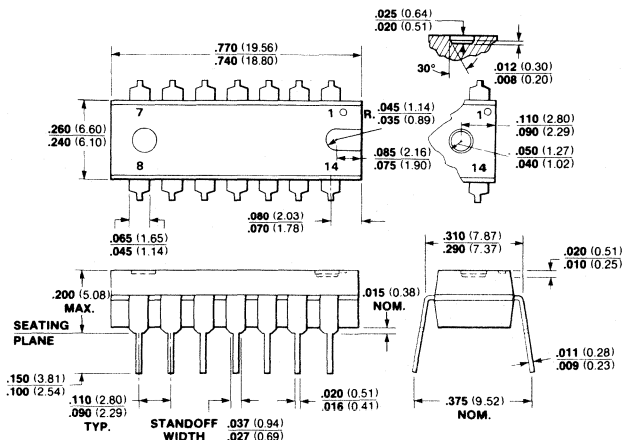

NOTES:

- Alloy 42 pins, tin plated
- Gold plated pins available
- Transfer moulded DM-6B plastic package
- Pins are intended for insertion in hole rows on .300" (7.62) centers
- They are purposely shipped with "positive" misalignment to facilitate insertion
- Board drilling dimensions should equal your practice for .020 (0.508) inch diameter pin
- Package weight is 0.9 gram

FAIRCHILD • DIODE ARRAYS

6B OUTLINE

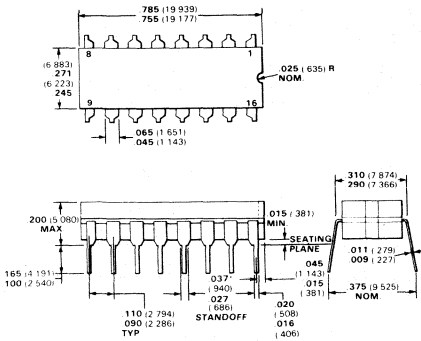

NOTES:

- Alloy 42 pins, tin plated
- Gold plated pins available
- Hermetically sealed ceramic package
- Pins are intended for insertion in hole rows on .300" centers (7.62)
- They are purposely shipped with "positive" misalignment to facilitate insertion
- Board-drilling dimensions should equal your practice for .020 inch diameter pin (0.51)
- Package weight is 2.0 grams
- *The .037-.027 dimension does not apply to the corner pins

9B OUTLINE

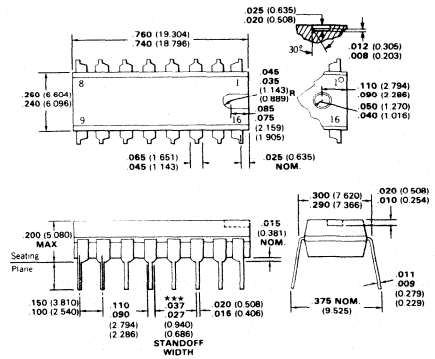

NOTES:

- Alloy 42 pins, tin plated
- Gold plated pins available
- Transfer moulded DM-6B plastic package
- Pins are intended for insertion in hole rows on .300" (7.62) centers
- Leads purposely have a "positive" misalignment to facilitate insertion
- Board-drilling dimensions should equal your practice for .020 inch (0.51) diameter pin
- *** The .037-.027 (0.94-0.69) dimension does not apply to the corner pins

FSA2619M • FSA2619P • FSA2620M • FSA2620P FSA2621M • FSA2719M • FSA2719P • FSA2720M FSA2720P • FSA2721M

PLANAR AIR-ISOLATED MONOLITHIC DIODE ARRAYS

- C ... 2.0 pF (MAX) FSA2719 Series
- ΔV_F ... 15 mV (MAX) @ 10 mA

ABSOLUTE MAXIMUM RATINGS (Notes 1 and 5)

Temperatures

Storage Temperature Range (M Suffix)	-55° C to +200° C
(P Suffix)	-55° C to +150° C
Maximum Junction Operating Temperature	+150° C
Lead Temperature	+260° C

Power Dissipation (Note 2)

Maximum Dissipation per Junction at 25° C Ambient	400 mW
Maximum Dissipation per Package at 25° C Ambient	650 mW
Linear Derating factor (from 25° C) Junction	3.2 mW / °C
Package	5.2 mW / °C

Maximum Voltage and Currents

WIV	Working Inverse Voltage FSA2619 (Note 5)	75 V
	FSA2719	50 V
I _F	Continuous Forward Current	350 mA
i _f (surge)	Peak Forward Surge Current	
	Pulse Width = 1.0 s	1.0 A
	Pulse Width = 1.0 μ s	2.0 A

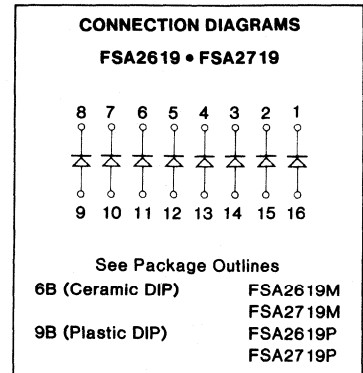

ELECTRICAL CHARACTERISTICS (25° C Ambient Temperature unless otherwise noted)

SYMBOL	CHARACTERISTIC	MIN	MAX	UNITS	TEST CONDITIONS
BV	Breakdown Voltage (Note 5)	FSA2719	75	V	I _R = 5.0 μ A
		FSA2619	100	V	I _R = 100 μ A
I _R	Reverse Current	FSA2619	5.0	μ A	V _R = 75 V
			25	nA	V _R = 20 V
		FSA2719	50	μ A	V _R = 20 V, T _A = 150° C
			100	nA	V _R = 50 V
		100	μ A	V _R = 50 V, T _A = 150° C	
V _F	Forward Voltage (Note 3)		1.0	V	I _F = 10 mA
t _{rr}	Reverse Recovery Time (Note 6)	FSA2619	5.0	ns	I _f = I _r = 10 mA, I _{rr} = 1.0 mA
		FSA2719	6.0	ns	I _f = I _r = 10 mA, I _{rr} = 1.0 mA
C	Capacitance (Note 6)	FSA2619	4.0	pF	V _R = 0
		FSA2719	2.0	pF	V _R = 0
ΔV_F	Forward Voltage Match (Note 6)		15	mV	I _F = 10 mA
t _{fr}	Forward Recovery Time (Note 6)	FSA2619	20	ns	50 mA Peak square wave, 0.1 μ s Pulse Width, 5.0 kHz - 100 kHz
V _{FM}	Peak Forward Voltage (Note 6)	FSA2719	3.0	V	I _F = 100 mA, t _r \leq 10 ns
RE	Rectification Efficiency	45		%	V _f = 2 V rms, f = 100 MHz

NOTES:

1. These ratings are limiting values above which life or satisfactory performance may be impaired.
2. These are steady state limits. The factory should be consulted or applications involving pulsed or low duty-cycle operation.
3. V_F is measured using an 8 ms pulse.
4. See test circuits (Note 6) for measurement of reverse current of an individual diode.
5. FSA2619 denotes series FSA2619M/P, FSA2620M/P and FSA2621M;
FSA2719 denotes series FSA2719M/P, FSA2720M/P and FSA2721M.
6. For product family characteristics curves and test circuits, refer to Chapter 4, D15.

* UNCONNECTED

FAIRCHILD • DIODE ARRAYS

TO-86 OUTLINE

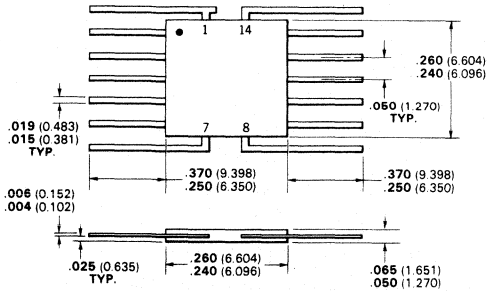

NOTES:
 Alloy 42 leads, tin plated
 Gold plated leads available
 Hermetically sealed ceramic package
 Dot or tab indicates lead 1
 Package weight is 0.27 gram

FSA2620 • FSA2621 FSA2720 • FSA2721

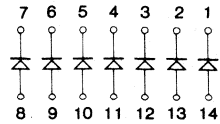

See Package Outlines

TO-116-2 (Ceramic)	FSA2620M
	FSA2720M
TO-116 (Plastic)	FSA2620P
	FSA2720P
TO-86	FSA2621M
	FSA2721M

6B OUTLINE

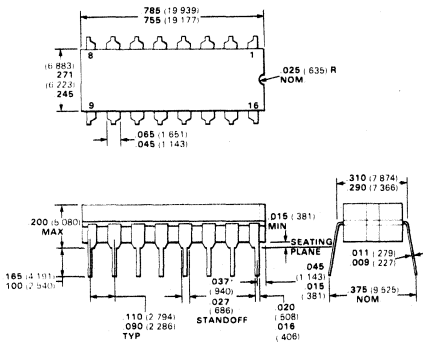

NOTES:
 Alloy 42 pins, tin plated
 Gold plated pins available
 Hermetically sealed ceramic package
 Pins are intended for insertion in hole rows on .300" centers (7.62)
 They are purposely shipped with "positive" misalignment to facilitate insertion
 Board-drilling dimensions should equal your practice for .020 inch diameter pin (0.51)
 Package weight is 2.0 grams
 *The .037-.027 dimension does not apply to the corner pins

9B OUTLINE

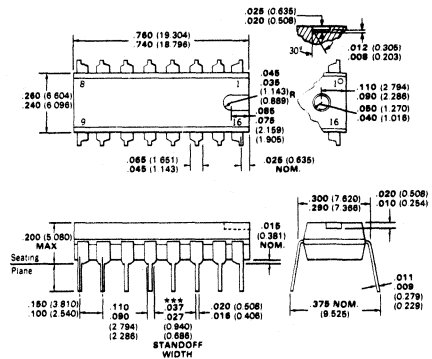

NOTES:
 Alloy 42 pins, tin plated
 Gold plated pins available
 Transfer moulded DM-6B plastic package
 Pins are intended for insertion in hole rows on .300" (7.62) centers
 Leads purposely have a "positive" misalignment to facilitate insertion
 Board-drilling dimensions should equal your practice for .020 inch (0.51) diameter pin
 ***The .037-.027 (0.94-0.69) dimension does not apply to the corner pins

FAIRCHILD • ZENER DIODES

TO-116 OUTLINE

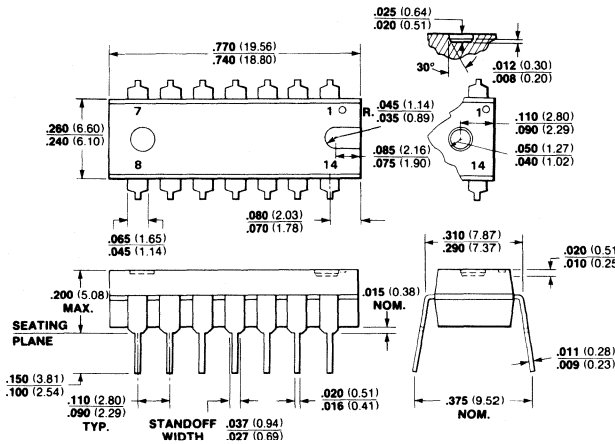

NOTES:

- Alloy 42 pins, tin plated
- Gold plated pins available
- Transfer moulded DM-6B plastic package
- Pins are intended for insertion in hole rows on .300" (7.62) centers
- They are purposely shipped with "positive" misalignment to facilitate insertion
- Board drilling dimensions should equal your practice for .020 (0.508) inch diameter pin
- Package weight is 0.9 gram

TO-116-2 OUTLINE

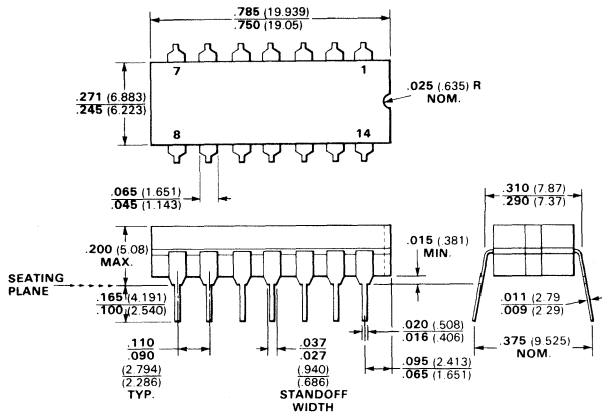

NOTES:

- Alloy 42 pins, tin plated
- Gold plated pins available
- Hermetically sealed ceramic package
- Pins are intended for insertion in hole rows on .300" (7.620) centers
- They are purposely shipped with "positive" misalignment to facilitate insertion
- Board-drilling dimensions should equal your practice for .020" (0.508) diameter pin
- Package weight is 2.0 grams

FSA2702M • FSA2703M • FSA2704M • FSA2705M

PLANAR AIR-ISOLATED MONOLITHIC DIODE BRIDGE ARRAYS

- $\Delta V_F \dots 3 \text{ mV (MAX) FSA2702M, FSA2703M}$
- $\Delta I_R \dots 1 \mu\text{A (MAX) FSA2702M, FSA2703M}$

ABSOLUTE MAXIMUM RATINGS (Note 1)

Temperatures

Storage Temperature Range	-55°C to +200°C
Maximum Junction Operating Temperature	175°C
Lead Temperature	+260°C

Power Dissipation (Note 2)

Maximum Dissipation	500 mW
Linear Derating Factor (from 25°C)	3.33 mW/°C

Maximum Voltage and Currents

WIV	Working Inverse Voltage	40 V
I_F	Continuous Forward Current	300 mA
I_f	Recurrent Peak Forward Current	600 mA
I_f (surge)	Peak Forward Surge Current	
	Pulse Width = 1.0 s	1.0 A
	Pulse Width = 1.0 μs	4.0 A

CONNECTION DIAGRAM

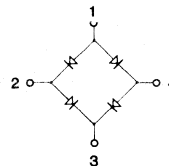

See Package Outlines

TO-33	FSA2702M, FSA2704M
TO-72	FSA2703M, FSA2705M

ELECTRICAL CHARACTERISTICS (25°C Ambient Temperature unless otherwise noted)

SYMBOL	CHARACTERISTIC	MIN	MAX	UNITS	TEST CONDITIONS
BV	Breakdown Voltage	60		V	$I_R = 100 \mu\text{A}$
I_R	Reverse Current (Note 4)		100 100	nA μA	$V_R = 40 \text{ V}$ $V_R = 40 \text{ V}, T_A = 150^\circ\text{C}$
C	Capacitance (Note 5)		4.0	pF	$V_R = 0$
V_F	Forward Voltage (Note 3)		1.000 .920 .850 .780 .740 .700 .650 .620	V V V V V V V V	$I_F = 200 \text{ mA}$ $I_F = 100 \text{ mA}$ $I_F = 50 \text{ mA}$ $I_F = 20 \text{ mA}$ $I_F = 10 \text{ mA}$ $I_F = 5.0 \text{ mA}$ $I_F = 2.0 \text{ mA}$ $I_F = 1.0 \text{ mA}$
t_{rr}	Reverse Recovery Time (Note 6)		6.0 8.0	ns ns	$I_f = I_r = 10 \text{ mA}, I_{rr} = 1.0 \text{ mA}$ $I_f = I_r = 200 \text{ mA}, I_{rr} = 20 \text{ mA}$
ΔV_f	Forward Voltage Match (Note 6) FSA2702, FSA2703		3.0	mV	$I_F = 10 \mu\text{A}$ to 10 mA $T_A = -55^\circ\text{C}$ to $+100^\circ\text{C}$
ΔI_R	Reverse Current Match (Note 6) FSA2702, FSA2703		1.0	μA	$V_R = 10 \text{ V}, T_A = -55^\circ\text{C}$ to $+100^\circ\text{C}$

NOTES:

1. These ratings are limiting values above which life or satisfactory performance may be impaired.
2. These are steady state limits. The factory should be consulted on applications involving pulsed or low duty-cycle operation.
3. V_F is measured using an 8 ms pulse.
4. See test circuits (Note 6) for measurement of reverse current of an individual diode.
5. The capacitance is measured from pin-to-pin across any one of the diodes. The interaction of other diodes is therefore included in the measured value.
6. For product family characteristic curves and test circuits, refer to Chapter 4, D15.

FAIRCHILD • DIODE ARRAYS

JEDEC TO-33 OUTLINE

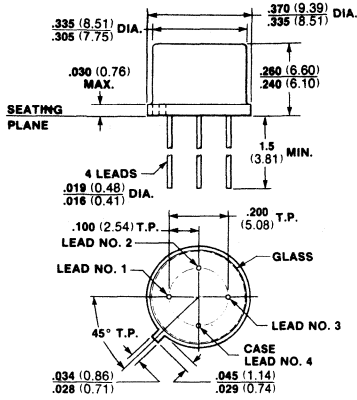

NOTES:
 Kovar leads, gold plated
 Hermetically sealed package
 Package weight is 1.22 grams

TO-72 OUTLINE

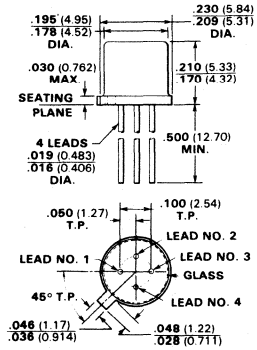

NOTES:
 Kovar leads, gold plated
 Hermetically sealed package
 Package weight is 0.36 gram

RF400 • RF401

AFC DIODES

SILICON PLANAR EPITAXIAL

- C_3/C_{20} ... 2.0 (MIN)
- Q ... 350 (MIN)

ABSOLUTE MAXIMUM RATINGS (Note 1)

Temperatures

Storage Temperature Range	-65°C to +200°C
Maximum Junction Operating Temperature	+175°C
Lead Temperature	+260°C

Power Dissipation (Note 2)

Maximum Total Power Dissipation at 25°C Ambient	350 mW
Linear Power Derating Factor	2.33 mW/°C

Maximum Voltage and Currents

WIV	Working Inverse Voltage	30 V
IF	Continuous Forward Current	250 mA

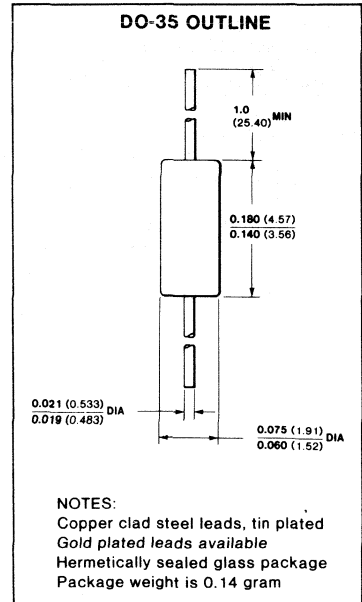

ELECTRICAL CHARACTERISTICS (25°C Ambient Temperature unless otherwise noted)

SYMBOL	CHARACTERISTIC	MIN	TYP	MAX	UNITS	TEST CONDITIONS
BV	Breakdown Voltage	35			V	$I_R = 10 \mu A$
I_R	Reverse Current		3.0 5.0	30 50	nA μA	$V_R = 30 V$ $V_R = 30 V, T_A = 150^\circ C$
Q	Figure of Merit	350				$V_R = 4.0 V, f = 50 MHz$
C	Capacitance		10 7.0		pF pF	$V_R = 4.0 V, f = 1 MHz$ $V_R = 4.0 V, f = 1 MHz$
$C_{0.1}/C_4$	Capacitance Ratio	2.0				$V_R = 0.1V (C_{0.1}), V_R = 4.0 V (C_4), f = 1 MHz$
C_3/C_{20}	Capacitance Ratio	2.0				$V_R = 3.0 V (C_3), V_R = 20 V (C_{20}), f = 1 MHz$

NOTES:

1. These ratings are limiting values above which the serviceability of the diode may be impaired.
2. These are steady state limits. The factory should be consulted on applications involving pulsed or low duty-cycle operation.
3. For product family characteristic curves, refer to Chapter 4, D8.

RF500

DUAL FM VARACTOR

DIFFUSED SILICON PLANAR DIODE

- C... 38–42 pF
- Q... 125 (MIN)

ABSOLUTE MAXIMUM RATINGS (Note 1)

Temperatures

Storage Temperature Range	-55°C to +150°C
Maximum Junction Operating Temperature	+150°C
Lead Temperature	+260°C

Power Dissipation (Note 2)

Maximum Total Power Dissipation at 25°C Ambient	280 mW
Linear Power Derating Factor	2.24 mW/°C

Maximum Voltage and Currents

WIV Working Inverse Voltage	30 V
IF Continuous Forward Current	200 mA

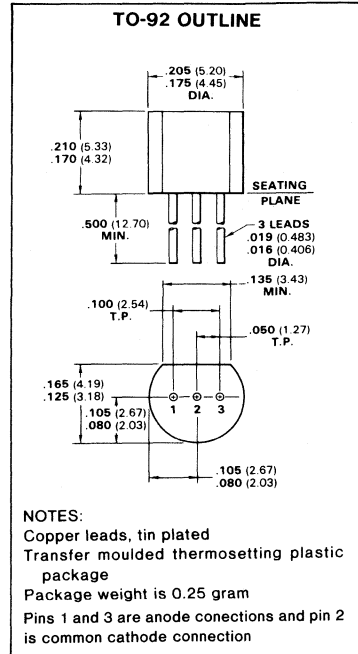

ELECTRICAL CHARACTERISTICS (25°C Ambient Temperature unless otherwise noted)

SYMBOL	CHARACTERISTIC	MIN	TYP	MAX	UNITS	TEST CONDITIONS
BV	Breakdown Voltage	35			V	$I_R = 10 \mu A$
I_R	Reverse Current		5.0 50	50 500	nA nA	$V_R = 30 V$ $V_R = 30 V, T_A = 60^\circ C$
C	Capacitance	38	40	42	pF	$V_R = 3 V, f = 1 MHz$
C3/C30	Capacitance Ratio	2.5	2.65	2.8		$V_R = 3/30 V, f = 1 MHz$
L_S	Series Inductance		6.0		nH	$f = 250 MHz, 1.5 m_m$ leads
R_D	Dynamic Resistance		0.2	0.4	Ω	$V_R @ 38 pF, f = 100 MHz$
C_C	Case Capacitance		0.18		pF	$f = 1 MHz, 1.5 m_m$ leads
TC_C	Capacitance Temperature Coefficient		280	400	ppm/°C	
Q	Figure of Merit	125	150			$V_R = 3 V, f = 100 MHz$

NOTES:

1. These ratings are limiting values above which the serviceability of the diode may be impaired.
2. These are steady state limits. The factor should be consulted on applications involving pulsed or low duty-cycle operation.
3. For product family characteristic curves, refer to Chapter 4, D9.

ZPD3,3 – ZPD33

500 mW SILICON ZENER DIODES

ABSOLUTE MAXIMUM RATINGS (Note 1)

Temperatures

Storage Temperature Range	-65°C to +200°C
Maximum Junction Operating Temperature	+175°C
Lead Temperature	+260°C

Power Dissipation (Note 2)

Maximum Total Power Dissipation at 25°C Ambient	500 mW
Linear Power Derating Factor	3.3 mW / °C

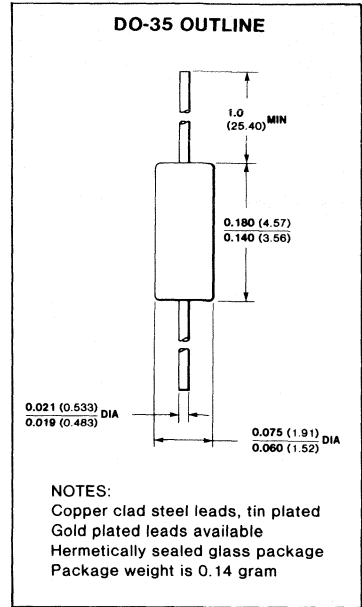

3

ELECTRICAL CHARACTERISTICS (25°C Ambient unless otherwise listed)

SYMBOL	V _Z			Z _Z		V _R	I _{ZM}		TC	
	Zener Voltage @I _Z = 5 mA			Max Zener	Impedance	Minimum Reverse Voltage @I _R = 100 nA	Maximum Zener Current		Temperature Coefficient of V _Z	
	MIN	NOM	MAX	I _Z = 5 mA f = 1 kHz	I _Z = 1 mA f = 1 kHz		25°C	45°C	MIN	MAX
UNIT	V	V	V	Ω	Ω	V	mA	mA	% / °C	% / °C
ZPD3,3	3.1	3.3	3.5	90	500	—	130	109	-0.080	-0.030
ZPD3,6	3.4	3.6	3.8	90	500	—	120	101	-0.080	-0.030
ZPD3,9	3.7	3.9	4.1	90	500	—	110	92	-0.070	-0.030
ZPD4,3	4.0	4.3	4.6	90	500	—	100	85	-0.060	-0.010
ZPD4,7	4.4	4.7	5.0	78	500	—	90	76	-0.050	+0.020
ZPD5,1	4.8	5.1	5.4	60	480	0.8	80	67	-0.030	+0.040
ZPD5,6	5.2	5.6	6.0	40	400	1.0	70	59	+0.020	+0.060
ZPD6,2	5.8	6.2	6.6	10	200	2.0	64	54	-0.010	+0.070
ZPD6,8	6.4	6.8	7.2	8.0	150	3.0	58	49	+0.020	+0.070
ZPD7,5	7.0	7.5	7.9	7.0	50	5.0	53	44	+0.030	+0.070
ZPD8,2	7.7	8.2	8.7	7.0	50	6.0	47	40	+0.040	+0.070
ZPD9,1	8.5	9.1	9.6	10	50	7.0	43	36	+0.050	+0.080
ZPD10	9.4	10.0	10.6	15	70	7.5	40	33	+0.050	+0.080
ZPD11	10.4	11.0	11.6	20	70	8.5	36	30	+0.050	+0.090
ZPD12	11.4	12.0	12.7	20	90	9.0	32	28	+0.060	+0.090
ZPD13	12.4	13.0	14.1	25	110	10.0	29	25	+0.070	+0.090

NOTES:

1. These ratings are limiting values above which the serviceability of the diode may be impaired.
2. These are steady state limits. The factory should be consulted on applications involving pulsed or low duty-cycle operation.
3. V_Z = 1.0 V (max) @I_Z = 100 nA for all types.
4. For product family characteristic curves, refer to Chapter 4, D13.

FAIRCHILD • ZPD SERIES

ELECTRICAL CHARACTERISTICS (25°C Ambient unless otherwise listed)

SYMBOL	V _Z			Z _Z		V _R	I _{ZM}		TC	
	Zener Voltage @I _Z = 5 mA			Max Zener	Impedance	Minimum Reverse Voltage @I _R = 100 nA	Maximum Zener Current		Temperature Coefficient of V _Z	
	MIN	NOM	MAX	I _Z = 5 mA f = 1 kHz	I _Z = 1 mA f = 1 kHz		25°C	45°C	MIN	MAX
UNIT	V	V	V	Ω	Ω	V	mA	mA	%/°C	%/°C
ZPD15	13.8	15.0	15.6	30	110	11.0	27	23	+0.070	+0.090
ZPD16	15.3	16.0	17.1	40	170	12.0	24	20	+0.080	+0.095
ZPD18	16.8	18.0	19.1	50	170	14.0	21	18	+0.080	+0.095
ZPD20	18.8	20.0	21.2	50	220	15.0	20	17	+0.080	+0.100
ZPD22	20.8	22.0	23.3	55	220	17.0	18	16	+0.080	+0.100
ZPD24	22.8	24.0	25.6	80	220	18.0	16	13	+0.080	+0.100
ZPD27	25.1	27.0	28.9	80	250	20.0	14	12	+0.080	+0.100
ZPD30	28.0	30.0	32.0	80	250	22.5	13	10	+0.080	+0.100
ZPD33	31.0	33.0	35.0	80	250	25.0	12	9	+0.080	+0.100

1N456/A • 1N457/A • 1N458/A • 1N459/A

LOW LEAKAGE DIODES

DIFFUSED SILICON PLANAR

- I_R ... 25 nA (MAX) @ WIV
- C ... 6.0 pF (MAX)

ABSOLUTE MAXIMUM RATINGS (Note 1)

Temperatures

Storage Temperature Range	-65°C to +200°C
Maximum Junction Operating Temperature	+175°C
Lead Temperature	+260°C

Power Dissipation (Note 2)

Maximum Total Power Dissipation at 25°C Ambient	500 mW
Linear Power Derating Factor (From 25°C)	3.33 mW/°C

Maximum Voltage and Currents

	1N456/A	1N457/A	1N458/A	1N459/A
WIV Working Inverse Voltage	25 V	60 V	125 V	175 V
I_O Average Rectified Current	200 mA			
I_F Continuous Forward Current	500 mA			
i_f Peak Repetitive Forward Current	600 mA			
$i_f(\text{surge})$ Peak Forward Surge Current	600 mA			
Pulse Width = 1 μ s	4.0 A			
Pulse Width = 1 s	1.0 A			

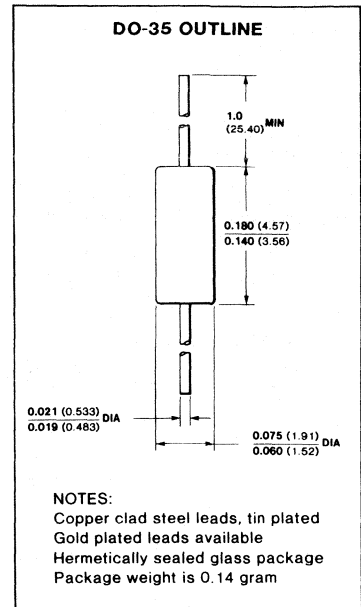

3

ELECTRICAL CHARACTERISTICS (25°C Ambient Temperature unless otherwise noted)

SYMBOL	CHARACTERISTIC	MIN	MAX	UNITS	TEST CONDITIONS
V_F	Forward Voltage 1N456A/7A/8A/9A		1.0	V	$I_F = 100$ mA
		1N456	1.0	V	$I_F = 40$ mA
		1N457	1.0	V	$I_F = 20$ mA
		1N458	1.0	V	$I_F = 7$ mA
		1N459	1.0	V	$I_F = 3$ mA
I_R	Reverse Current		25	nA	$V_R = \text{Rated WIV}$
			5.0	μ A	$V_R = \text{Rated WIV}, T_A = 150^\circ\text{C}$
BV	Breakdown Voltage	1N456/A	30	V	$I_R = 100$ μ A
		1N457/A	70	V	$I_R = 100$ μ A
		1N458/A	150	V	$I_R = 100$ μ A
		1N459/A	200	V	$I_R = 100$ μ A
C	Capacitance		6.0	pF	$V_R = 0, f = 1$ MHz

NOTES:

1. These ratings are limiting values above which the serviceability of the diode may be impaired.
2. These are steady state limits. The factory should be consulted on applications involving pulsed or low duty-cycle operation.
3. For product family characteristic curves, refer to Chapter 4, D2.

IN461A • IN462A • IN463A • IN464A

GENERAL PURPOSE, HIGH CONDUCTANCE DIODES

DIFFUSED SILICON PLANAR

- $V_F \dots 1.0 \text{ V (MAX) @ } 100 \text{ mA}$
- $I_R \dots 500 \text{ nA (MAX) @ WIV}$

ABSOLUTE MAXIMUM RATINGS (Note 1)

Temperatures

Storage Temperature Range	-65°C to +200°C
Maximum Junction Operating Temperature	+175°C
Lead Temperature	+260°C

Power Dissipation (Note 2)

Maximum Total Power Dissipation at 25°C Ambient	500 mW
Linear Power Derating Factor (from 25°C)	3.33 mW / °C

Maximum Voltage and Currents

	IN461A	IN462A	IN463A	IN464A
WIV Working Inverse Voltage	25 V	60 V	175 V	125 V
I_O Average Rectified Current	200 mA	200 mA	200 mA	200 mA
I_F Continuous Forward Current	500 mA	500 mA	500 mA	500 mA
$I_{f(peak)}$ Peak Repetitive Forward Current	600 mA	600 mA	600 mA	600 mA
$i_{f(surge)}$ Peak Forward Surge Current				
Pulse Width = 1 s	1.0 A	1.0 A	1.0 A	1.0 A
Pulse Width = 1 μ s	4.0 A	4.0 A	4.0 A	4.0 A

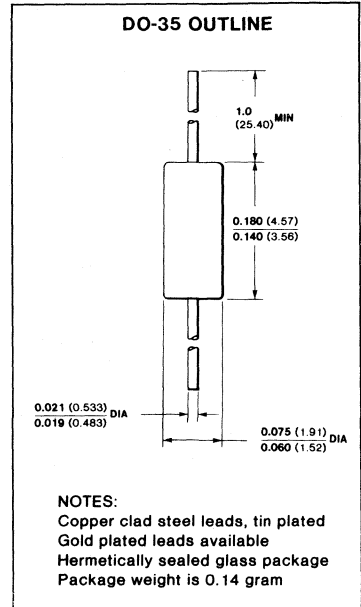

ELECTRICAL CHARACTERISTICS (25°C Ambient Temperature unless otherwise noted)

SYMBOL	CHARACTERISTIC	MIN	MAX	UNITS	TEST CONDITIONS
V_F	Forward Voltage		1.0	V	$I_f = 100 \text{ mA}$
I_R	Reverse Current		500 30	nA μ A	$V_R = \text{Rated WIV}$ $V_R = \text{Rated WIV}, T_A = 150^\circ\text{C}$
BV	Breakdown Voltage	IN461A IN462A IN463A IN464A	30 70 200 150	V V V V	$I_R = 100 \mu\text{A}$ $I_R = 100 \mu\text{A}$ $I_R = 100 \mu\text{A}$ $I_R = 100 \mu\text{A}$

NOTES:

1. These ratings are limiting values above which the serviceability of the diode may be impaired.
2. These are steady state limits. The factory should be consulted on applications involving pulsed or low duty-cycle operation.
3. For product family characteristic curves, refer to Chapter 4, D2.

1N482B • 1N483B • 1N484B • 1N485B • 1N486B

GENERAL PURPOSE, LOW LEAKAGE DIODES

DIFFUSED SILICON PLANAR

- $V_F \dots 1.0 \text{ V (MAX) @ } 100 \text{ mA}$
- $I_R \dots 25 \text{ nA (MAX) @ WIV}$

ABSOLUTE MAXIMUM RATINGS (Note 1)

Temperatures

Storage Temperature Range	-65°C to +200°C
Maximum Junction Operating Temperature	+175°C
Lead Temperature (from 25°C)	+260°C

Power Dissipation (Note 2)

Maximum Total Power Dissipation at 25°C Ambient	500 mW
Linear Power Derating Factor (from 25°C)	3.33 mW/°C

Maximum Voltage and Currents

	1N482B	1N483B	1N484B	1N485B	1N486B
WIV Working Inverse Voltage	36 V	70 V	130 V	180 V	225 V
I_O Average Rectified Current					200 mA
I_F Continuous Forward Current					500 mA
i_f Peak Repetitive Forward Current					600 mA
$i_f(\text{surge})$ Peak Forward Surge Current					1.0
Pulse Width = 1 s					4.0
Pulse Width = 1 μ s					

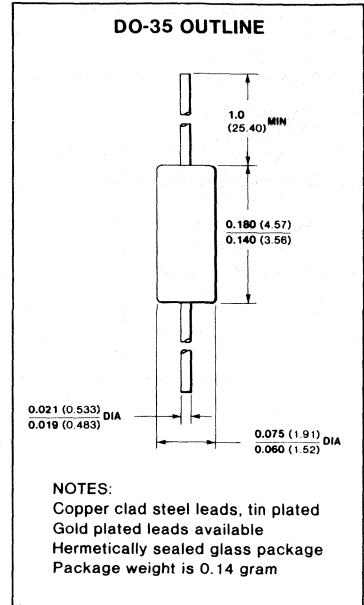

3

ELECTRICAL CHARACTERISTICS (25°C Ambient Temperature unless otherwise noted)

SYMBOL	CHARACTERISTIC	MIN	MAX	UNITS	TEST CONDITIONS
V_F	Forward Voltage		1.0	V	$I_F = 100 \text{ mA}$
I_R	Reverse Current	1N482B - 1N485B	25	nA	$V_R = \text{Rated WIV}$
		1N486B	5.0	μ A	$V_R = \text{Rated WIV}, T_A = 150^\circ\text{C}$
			50	nA	$V_R = 225 \text{ V}$
			10	μ A	$V_R = 225 \text{ V}, T_A = 150^\circ\text{C}$
BV	Breakdown Voltage	1N482B	40	V	$I_R = 100 \mu\text{A}$
		1N483B	80	V	$I_R = 100 \mu\text{A}$
		1N484B	150	V	$I_R = 100 \mu\text{A}$
		1N485B	200	V	$I_R = 100 \mu\text{A}$
		1N486B	250	V	$I_R = 100 \mu\text{A}$

NOTES:

1. These ratings are limiting values above which the serviceability of the diode may be impaired.
2. These are steady state limits. The factory should be consulted on applications involving pulsed or low duty-cycle operation.
3. For product family characteristic curves, refer to Chapter 4, D2.

1N625 through 1N629

GENERAL PURPOSE DIODES

DIFFUSED SILICON PLANAR

- $V_F \dots 1.5 \text{ V (MAX) @ } 4.0 \text{ mA}$
- $I_R \dots 1.0 \mu\text{A (MAX) @ WIV}$

ABSOLUTE MAXIMUM RATINGS (Note 1)

Temperatures

Storage Temperature Range	-65°C to +200°C
Maximum Operating Junction Temperature	175°C
Lead Temperatures	260°C

Power Dissipation (Notes 2)

Maximum Total Dissipation at 25°C Ambient	500 mW
Linear Derating Factor (from 25°C)	3.33 mW/°C

Maximum Voltage and Currents

	1N625	1N626	1N627	1N628	1N629
WIV Working Inverse Voltage	20 V	35 V	75 V	125 V	175 V
I_O Average Rectified Current	175 mA	175 mA	175 mA	175 mA	175 mA
I_F Forward Current Steady State	400 mA	400 mA	400 mA	400 mA	400 mA
$I_{f(\text{surge})}$ Peak Forward Surge Current					
Pulse Width = 1.0 s	1.0 A	1.0 A	1.0 A	1.0 A	1.0 A
Pulse Width = 1.0 μs	4.0 A	4.0 A	4.0 A	4.0 A	4.0 A

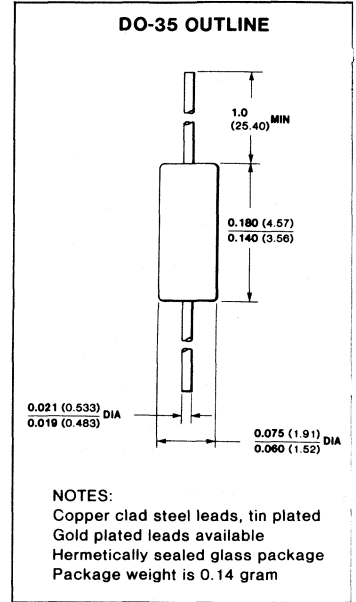

ELECTRICAL CHARACTERISTICS (25°C Ambient Temperature unless otherwise noted)

SYMBOL	CHARACTERISTIC	MIN	MAX	UNITS	TEST CONDITIONS
V_F	Forward Voltage		1.5	V	$I_F = 4.0 \text{ mA}$
I_R	Reverse Current		1.0 30	μA μA	$V_R = \text{rated WIV}$ $V_R = \text{rated WIV, } T_A = 100^\circ\text{C}$
BV	Breakdown Voltage	1N625 1N626 1N627 1N628 1N629	30 50 100 150 200	V V V V V	$I_R = 100 \mu\text{A}$ $I_R = 100 \mu\text{A}$ $I_R = 100 \mu\text{A}$ $I_R = 100 \mu\text{A}$ $I_R = 100 \mu\text{A}$
t_{rr}	Reverse Recovery Time		1.0	μs	$I_F = 30 \text{ mA, } V_R = 35 \text{ V,}$ Recovery to 400 k Ω

NOTES:

1. The maximum ratings are limiting values above which life or satisfactory performance may be impaired.
2. These are steady state limits. The factory should be consulted on applications involving pulsed or low duty cycle operations.
3. For product family characteristic curves, refer to Chapter 4, D1.

1N658

GENERAL PURPOSE DIODES

DIFFUSED SILICON PLANAR EPITAXIAL

- BV... 120 V (MIN) @ 100 μ A
- V_F... 1.0 V (MAX) @ 100 mA

ABSOLUTE MAXIMUM RATINGS (Note 1)

Temperatures

Storage Temperature Range	-65°C to +200°C
Maximum Operating Junction Temperature	+175°C
Lead Temperature	+200°C

Power Dissipation (Note 2)

Maximum Total Dissipation at 25°C Ambient	500 mW
Linear Derating Factor (from 25°C)	3.33 mW/°C

Maximum Voltage and Currents

WIV	Working Inverse Voltage	100 V
I _O	Average Rectified Current	200 mA
I _F	Forward Current Steady State	500 mA
I _f (surge)	Peak Forward Surge Current	
	Pulse Width = 1.0 s	1.0 A
	Pulse Width = 1.0 μ s	4.0 A

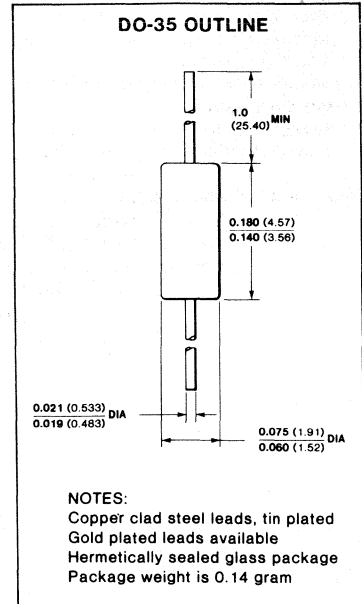

3

ELECTRICAL CHARACTERISTICS (25°C Ambient Temperature unless otherwise noted)

SYMBOL	CHARACTERISTIC	MIN	MAX	UNITS	TEST CONDITIONS
V _F	Forward Voltage		1.0	V	I _F = 100 mA
I _R	Reverse Current		50 25	nA μ A	V _R = 50 V V _R = 50 V, T _A = 150°C
BV	Breakdown Voltage	120		V	I _R = 100 μ A
t _{rr}	Reverse Recovery Time		300	ns	V _R = 40 V, I _f = 5.0 mA, R _L = 2.0 k Ω , C _L = 10 pF, Recovery to 80 k Ω

NOTES:

1. The maximum ratings are limiting values above which life or satisfactory performance may be impaired.
2. These are steady state limits. The factory should be consulted on applications involving pulsed or low duty cycle operations.
3. For product family characteristic curves, refer to Chapter 4, D1.

1N659 • 1N660 • 1N661

GENERAL PURPOSE DIODES

DIFFUSED SILICON PLANAR

- $V_F \dots 1.0 \text{ V (MAX) @ } 6.0 \text{ mA}$
- $t_{rr} \dots 300 \text{ ns (MAX)}$

ABSOLUTE MAXIMUM RATINGS (Note 1)

Temperatures

Storage Temperature Range	-65°C to +200°C
Maximum Operating Junction Temperature	+175°C
Lead Temperature	+260°C

Power Dissipation (Notes 2)

Maximum Total Dissipation at 25°C Ambient	500 mW
Linear Derating Factor (from 25°C)	3.33 mW/°C

Maximum Voltage and Currents

	1N659	1N660	1N661	
WIV Working Inverse Voltage	50 V	100 V	200 V	
I_O Average Rectified Current	200 mA	200 mA	200 mA	
I_F Forward Current Steady State	500 mA	500 mA	500 mA	
$i_{f(\text{surge})}$ Peak Forward Surge Current				
	Pulse Width = 1.0 s	1.0 A	1.0 A	1.0 A
	Pulse Width = 1.0 μ s	4.0 A	4.0 A	4.0 A

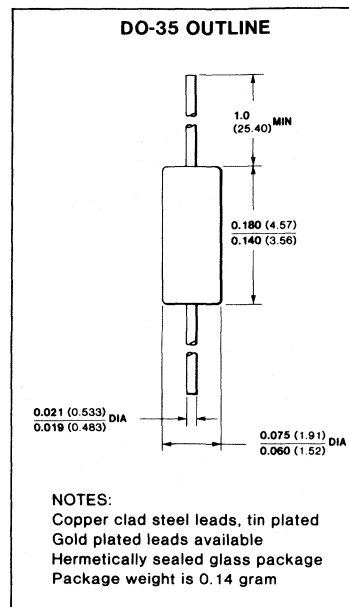

ELECTRICAL CHARACTERISTICS (25°C Ambient Temperature unless otherwise noted)

SYMBOL	CHARACTERISTIC	1N659		1N660		1N661		UNITS	TEST CONDITIONS
		MIN	MAX	MIN	MAX	MIN	MAX		
V_F	Forward Voltage		1.0		1.0		1.0	V	$I_F = 6.0 \text{ mA}$
I_R	Reverse Current		5.0		5.0		10	μ A	$V_R = 50 \text{ V}$ $V_R = 100 \text{ V}$ $V_R = 200 \text{ V}$ $V_R = 50 \text{ V}, T_A = 100^\circ\text{C}$ $V_R = 100 \text{ V}, T_A = 100^\circ\text{C}$ $V_R = 200 \text{ V}, T_A = 100^\circ\text{C}$
			25		50		100	μ A	
								μ A	
								μ A	
BV	Breakdown Voltage	60		120		240		V	$I_R = 100 \mu\text{A}$
t_{rr}	Reverse Recovery Time		300		300		300	ns	$V_r = 35 \text{ V}, I_f = 30 \text{ mA}, R_L = 2.0 \text{ k}\Omega,$ $C_L = 10 \text{ pF}, \text{Recovery to } 400 \text{ k}\Omega$

NOTES:

1. The maximum ratings are limiting values above which life or satisfactory performance may be impaired.
2. These are steady state limits. The factory should be consulted on applications involving pulsed or low duty cycle operations.
3. For product family characteristic curves, refer to Chapter 4, D4 for 1N659, 4, D1 for 1N660 and 1N661.

1N746 – 1N759

500 mW SILICON ZENER DIODES

ABSOLUTE MAXIMUM RATINGS (Note 1)

Temperatures

Storage Temperature Range	-65°C to +200°C
Maximum Junction Operating Temperature	+175°C
Lead Temperature	+260°C

Power Dissipation (Note 2)

Maximum Total Power Dissipation at 25°C Ambient	500 mW
Linear Power Derating Factor (from 25°C)	3.33 mW / °C

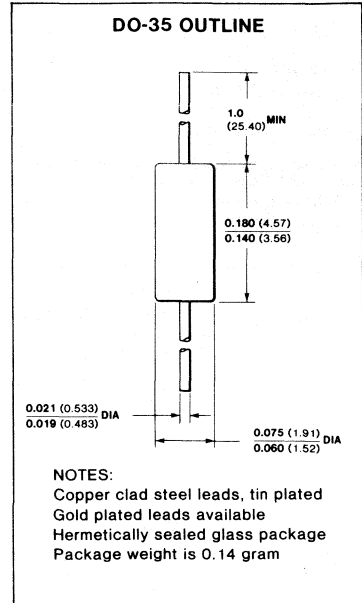

3

ELECTRICAL CHARACTERISTICS (25°C Ambient unless otherwise noted)

SYMBOL CHARACTERISTIC	Z_Z	V_Z	I_R		TC
	Maximum Zener Impedance (Note 4) ($I_Z = 20$ mA)	Nominal Zener Voltage (Note 3) ($I_Z = 20$ mA)	Maximum Reverse Current ($V_R = 1.0V$)		Typical Temperature Coefficient of V_Z
			@25°C	@150°C	
UNIT	Ω	V	μA	μA	% / °C
IN746	28.0	3.3	10.0	30.0	-0.070
IN747	24.0	3.6	10.0	30.0	-0.065
IN748	23.0	3.9	10.0	30.0	-0.060
IN749	22.0	4.3	2.0	30.0	-0.055
IN750	19.0	4.7	2.0	30.0	-0.043
IN751	17.0	5.1	1.0	20.0	± 0.030
IN752	11.0	5.6	1.0	20.0	± 0.028
IN753	7.0	6.2	0.1	20.0	+0.045
IN754	5.0	6.8	0.1	20.0	+0.050
IN755	6.0	7.5	0.1	20.0	+0.058
IN756	8.0	8.2	0.1	20.0	+0.062
IN757	10.0	9.1	0.1	20.0	+0.068
IN758	17.0	10.0	0.1	20.0	+0.075
IN759	30.0	12.0	0.1	20.0	+0.077

NOTES:

1. These ratings are limiting values above which the serviceability of the diode may be impaired.
2. These are steady state limits. The factory should be consulted on applications involving pulsed or low duty-cycle operation.
3. Type numbers without suffix have $\pm 10\%$ tolerance on nominal V_Z .
Type numbers with suffix A have $\pm 5\%$ tolerance on nominal V_Z .
4. The Zener impedance Z_Z is derived by superimposing a 60 Hz 2 mA (rms) signal on the 20 mA I_Z test current.
5. For product family characteristic curves, refer to Chapter 4, D13.

1N914/A/B · 1N916/A/B · 1N4148/9 · 1N4446-1N4449

HIGH CONDUCTANCE ULTRA FAST SWITCHING DIODES

DIFFUSED SILICON PLANAR

- t_{rr} ... 4.0 ns (MAX)
- BV ... 100 V (MIN)

ABSOLUTE MAXIMUM RATINGS (Note 1)

Temperatures

Storage Temperature Range
Max Junction Operating Temperature
Lead Temperature

-65° to +200°C
+175°C
+260°C

Power Dissipation (Note 2)

Maximum Total Dissipation at 25°C
Linear Derating Factor (from 25°C)

500 mW
3.33 mW/°C

Maximum Voltage and Currents

WIV Working Inverse Voltage
 I_O Average Rectified Current
 I_f DC Forward Current
 i_f Recurrent Peak Forward Current
 $i_f(\text{surge})$ Peak Forward Surge Current
Pulse Width = 1.0 s
Pulse Width = 1.0 μ s

75 V
200 mA
300 mA
400 mA

1.0 A
4.0 A

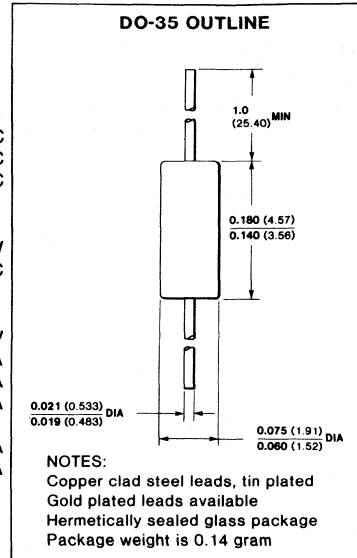

ELECTRICAL CHARACTERISTICS (25°C Ambient Temperature unless otherwise noted)

SYMBOL	CHARACTERISTIC	MIN	MAX	UNITS	TEST CONDITIONS
BV	Breakdown Voltage	100 75		V V	$I_R = 100 \mu A$ $I_R = 5.0 \mu A$
I_R	Reverse Current		25 50 5.0	nA μA μA	$V_R = 20 V$ $V_R = 20 V, T_A = 150^\circ C$ $V_R = 75 V$
V_F	Forward Voltage	0.62 0.63	0.72 0.73 1.0 1.0 1.0 1.0	V V V V V V	$I_F = 5.0 mA$ $I_F = 5.0 mA$ $I_F = 10 mA$ $I_F = 20 mA$ $I_F = 30 mA$ $I_F = 100 mA$
t_{rr}	Reverse Recovery Time		4.0	ns	$I_f = 10 mA, V_r = 6.0 V,$ $R_L = 100 \Omega$ Rec. to 1.0 mA
C	Capacitance		4.0 2.0	pF pF	$V_R = 0, f = 1 MHz$ $V_R = 0, f = 1 MHz$
V_{fr}	Peak Forward Recovery Voltage		2.5	V	50 mA Peak Square Wave, 0.1 μs pulse width, 5 kHz - 100 kHz rep. rate
RE	Rectification Efficiency		45	%	2.0 V rms, f = 100 MHz

NOTES:

1. Maximum ratings are limiting values above which life or satisfactory performance may be impaired.
2. These are steady state limits. The factory should be consulted on applications involving pulsed or low duty-cycle operation.
3. For family characteristic curves, refer to Chapter 4, D4.

1N957 - 1N973

500 mW SILICON PLANAR ZENER DIODES

ABSOLUTE MAXIMUM RATINGS (Note 1)

Temperatures

Storage Temperature Range	-65°C to +200°C
Maximum Junction Operating Temperature	+175°C
Lead Temperature	+260°C

Power Dissipation (Note 2)

Maximum Total Power Dissipation at 25°C Ambient	500 mW
Linear Power Derating Factor (from 25°C)	3.33 mW/°C

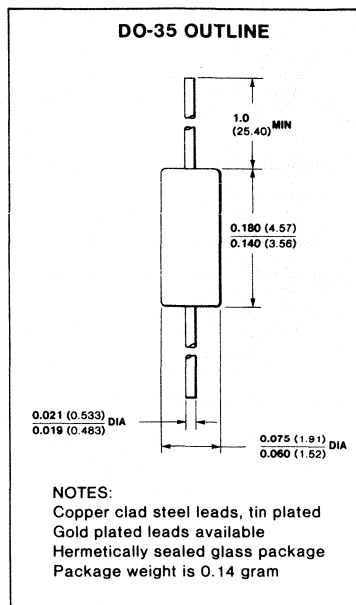

ELECTRICAL CHARACTERISTICS (25°C Ambient)

SYMBOL	V_Z		I_{ZT}	Z_{ZK}		I_{ZK}	I_R	V_{RT}			TC	I_{ZM}				
	Nominal Zener Voltage (Note 3)	Maximum Zener Impedance (Note 4)		Test Current	Maximum Zener Knee Impedance (Note 4)			Test Current	Maximum Reverse Current @ V_{RT}	Test Voltage			Typical Temperature Coefficient of V_Z	Maximum Zener Current (Note 5)		
										$\pm 20\%$ Tolerance					$\pm 10\%$ Tolerance	$\pm 5\%$ Tolerance
UNIT	V	Ω	mA	Ω	mA	μA	V	V	V	%/°C	mA					
1N957	6.8	4.5	18.5	700	1.0	150	4.4	4.9	5.2	+0.050	47					
1N958	7.5	5.5	16.5	700	0.5	75	4.8	5.4	5.7	+0.058	42					
1N959	8.2	6.5	15.0	700	0.5	50	5.2	5.9	6.2	+0.062	38					
1N960	9.1	7.5	14.0	700	0.5	25	5.8	6.6	6.9	+0.068	35					
1N961	10.0	8.5	12.5	700	0.25	10	6.4	7.2	7.6	+0.072	32					
1N962	11.0	9.5	11.5	700	0.25	5.0	7.0	8.0	8.4	+0.073	28					
1N963	12.0	11.5	10.5	700	0.25	5.0	7.6	8.6	9.1	+0.076	26					
1N964	13.0	13.0	9.5	700	0.25	5.0	8.3	9.4	9.9	+0.079	24					
1N965	15.0	16.0	8.5	700	0.25	5.0	9.6	10.8	11.4	+0.082	21					
1N966	16.0	17.0	7.8	700	0.25	5.0	10.2	11.5	12.2	+0.083	19					
1N967	18.0	21.0	7.0	750	0.25	5.0	11.5	13.0	13.7	+0.085	17					
1N968	20.0	25.0	6.2	750	0.25	5.0	12.8	14.4	15.2	+0.086	15					
1N969	22.0	29.0	5.6	750	0.25	5.0	14.0	15.8	16.7	+0.087	14					
1N970	24.0	33.0	5.2	750	0.25	5.0	15.4	17.3	18.2	+0.088	13					
1N971	27.0	41.0	4.6	750	0.25	5.0	17.2	19.4	20.6	+0.090	11					
1N972	30.0	49.0	4.2	1000	0.25	5.0	19.2	21.6	22.8	+0.091	10					
1N973	33.0	58.0	3.8	1000	0.25	5.0	21.1	23.8	25.1	± 0.092	9.2					

NOTES:

1. These ratings are limiting values above which the serviceability of the diode may be impaired.
2. These are steady state limits. The factory should be consulted on applications involving pulsed or low duty-cycle operation.
3. Type numbers without suffix have $\pm 20\%$ tolerance on nominal V_Z .
 Type numbers with suffix A have $\pm 10\%$ tolerance on nominal V_Z .
 Type numbers with suffix B have $\pm 5\%$ tolerance on nominal V_Z .
4. The Zener impedances Z_Z and Z_{ZK} are derived by superimposing a 60 Hz signal on test currents I_{ZT} and I_{ZK} , having an RMS value of 10% of the d.c. value of I_{ZT} and I_{ZK} respectively.
5. Maximum Zener Current (I_{ZM}) is based on the maximum Zener voltage of a 20% tolerance unit.
6. For product family characteristic curves, refer to Chapter 4, D13.

1N3064 • 1N4305 • 1N4454

ULTRA FAST LOW CAPACITANCE DIODES

DIFFUSED SILICON PLANAR

- C ... 2.0 pF @ $V_R = 0$, $f = 1.0$ MHz
- t_{rr} ... 4.0 ns @ $I_f = 10$ mA, $I_r = 10$ mA, $V_r = 1.0$ V
- BV ... 75 V (MIN)

ABSOLUTE MAXIMUM RATINGS (Note 1)

Temperatures

Storage Temperature Range	-65°C to +200°C
Max Junction Operating Temperature	+175°C
Lead Temperature	+260°C

Power Dissipation (Note 2)

Maximum Total Dissipation at 25°C	500 mW
Linear Derating Factor (from 25°C)	3.33 mW/°C

Maximum Voltages and Currents

WIV	Working Inverse Voltage	50 V
I_O	Average Rectified Current	100 mA
I_F	Forward Current Steady State	300 mA
i_f	Recurrent Peak Forward Current	400 mA
i_f (surge)	Peak Forward Surge Current	
	Pulse Width = 1.0 s	1.0 A
	Pulse Width = 1.0 μ s	4.0 A

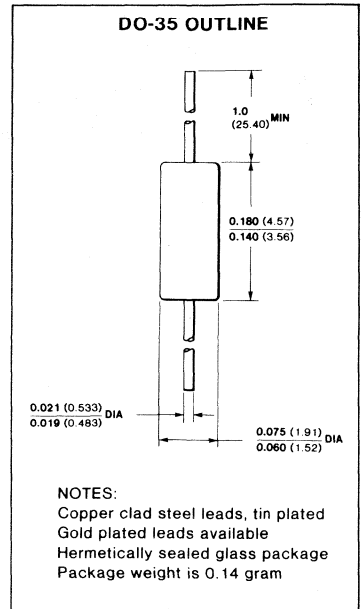

ELECTRICAL CHARACTERISTICS (25°C Ambient Temperature unless otherwise noted)

SYMBOL	CHARACTERISTIC	MIN	MAX	UNITS	TEST CONDITIONS
V_F	Forward Voltage	0.610	0.710	V	$I_F = 2.0$ mA
		0.550	0.650	V	$I_F = 1.0$ mA
		0.505	0.575	V	$I_F = 250$ μ A
			1.0	V	$I_F = 10$ mA
			0.85	V	$I_F = 10$ mA
I_R	Reverse Current		0.1 100	μ A μ A	$V_R = 50$ V $V_R = 50$ V, $T_A = 150^\circ$ C
BV	Breakdown Voltage	75		V	$I_R = 5.0$ μ A
t_{rr}	Reverse Recovery Time (Note 3)	1N4305	2.0	ns	$I_f = 10$ mA, $V_r = 6.0$ V, $R_L = 100$ Ω
		1N3064 } 1N4305 } 1N4454 }	4.0	ns	$I_f = I_r = 10$ mA, $R_L = 100$ Ω , $V_r = 1.0$ V
C	Capacitance		2.0	pF	$V_R = 0$, $f = 1.0$ MHz
RE	Rectification Efficiency (Note 4)	45		%	$f = 1.0$ MHz
$\Delta V_F / ^\circ$ C	Forward Voltage Temperature Coefficient (Note 5)		3.0	mV/°C	

NOTES:

1. The maximum ratings are limiting values above which life or satisfactory performance may be impaired.
2. These are steady state limits. The factory should be consulted on applications involving pulsed or low duty-cycle operation.
3. Recovery to 1.0 mA.
4. Rectification efficiency is defined as the ratio of dc load voltage to peak rf input voltage to the detector circuit, measured with 2.0 V rms input to the circuit. Load resistance 5.0 Ω , load capacitance 20 pF.
5. This value for $\Delta V_F / ^\circ$ C is a typical value not a minimum or maximum.
6. For product family characteristic curves, refer to Chapter 4, D4.

1N3070 • 1N4938

HIGH SPEED HIGH CONDUCTANCE DIODES

DIFFUSED SILICON PLANAR

- BV... 200 V (MIN)
- I_R... 100 nA (MAX)

ABSOLUTE MAXIMUM RATINGS (Note 1)

Temperatures

Storage Temperature Range	-65°C to +200°C
Max Junction Operating Temperature	+175°C
Lead Temperature	+260°C

Power Dissipation (Note 2)

Maximum Total Dissipation at 25°C Ambient	500 mW
Linear Derating Factor (from 25°C)	3.33 mW / °C

Maximum Voltage and Currents

WIV	Working Inverse Voltage	175 V
I _O	Average Rectified Current	200 mA
I _F	Forward Current Steady State DC	500 mA
i _f	Recurrent Peak Forward Current	600 mA
i _f (surge)	Peak Forward Surge Current	
	Pulse Width = 1.0 s	1.0 A
	Pulse Width = 1.0 μs	4.0 A

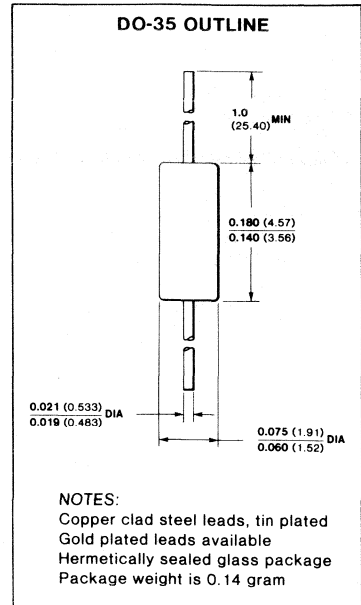

3

ELECTRICAL CHARACTERISTICS (25°C Ambient Temperature unless otherwise noted)

SYMBOL	CHARACTERISTIC	MIN	MAX	UNITS	TEST CONDITIONS
I _R	Reverse Current		100 100	nA μA	V _R = 175 V V _R = 175 V, T _A = 150°C
BV	Breakdown Voltage	200		V	I _R = 100 μA
V _F	Forward Voltage		1.0	V	I _F = 100 mA
C	Capacitance		5.0	pF	V _R = 0, f = 1.0 MHz
t _{rr}	Reverse Recovery Time (Note 3)		50	ns	I _F = I _R = 30 mA, R _L = 100 Ω
RE	Rectification Efficiency (Note 4)	35		%	f = 100 MHz

NOTES:

1. The maximum ratings are limiting values above which life or satisfactory performance may be impaired.
2. These are steady state limits. The factory should be consulted on applications involving pulsed or low duty-cycle operation.
3. Recovery to 1.0 mA.
4. Rectification efficiency is defined as the ratio of dc load voltage to peak rf input voltage to the detector circuit, measured with 2.0 V rms input to the circuit. Load resistance: 5.0 kΩ, load capacitance 20 pF.
5. 1N3070 and 1N4938 are electrically and mechanically identical.
6. For product family characteristic curves, refer to Chapter 4, D1.

1N3595 • IN6099

HIGH CONDUCTANCE LOW LEAKAGE DIODES

DIFFUSED SILICON PLANAR

- BV... 150 V (MIN) @ 100 μ A
- V_F ... 1.0 V @ 200 mA

ABSOLUTE MAXIMUM RATINGS (Note 1)

Temperatures

Storage Temperature Range	-65°C to +200°C
Max Junction Operating Temperature	+175°C
Lead Temperature	+260°C

Power Dissipation (Note 2)

Maximum Total Dissipation at 25°C Ambient	500 mW
Linear Derating Factor (From 25°C)	3.33 mW / °C

Maximum Voltage and Currents

WIV	Working Inverse Voltage	125 V
I_O	Average Rectified Current	200 mA
I_F	Forward Current Steady State	500 mA
i_f	Peak Repetitive Forward Current	600 mA
i_f (surge)	Peak Forward Surge Current	
	Pulse Width = 1.0 s	1.0 A
	Pulse Width = 1.0 μ s	4.0 A

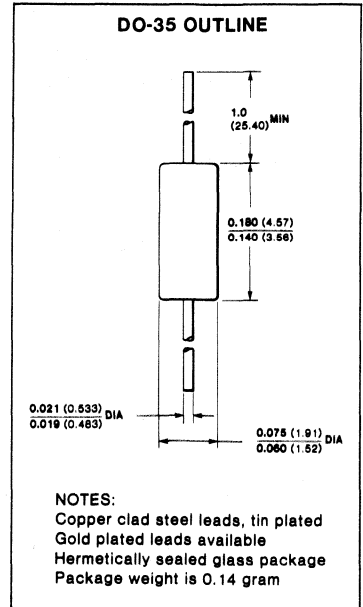

ELECTRICAL CHARACTERISTICS (25°C Ambient Temperature unless otherwise noted)

SYMBOL	CHARACTERISTIC	MIN	MAX	UNITS	TEST CONDITIONS
V_F	Forward Voltage	0.83	1.0	V	$I_F = 200$ mA
		0.79	0.92	V	$I_F = 100$ mA
		0.75	0.88	V	$I_F = 50$ mA
		0.65	0.80	V	$I_F = 10$ mA
		0.60	0.75	V	$I_F = 5.0$ mA
		0.52	0.68	V	$I_F = 1.0$ mA
I_R	Reverse Current		1.0	nA	$V_R = 125$ V
			300	nA	$V_R = 30$ V, $T_A = 125^\circ$ C
			500	nA	$V_R = 125$ V, $T_A = 125^\circ$ C
			3.0	μ A	$V_R = 125$ V, $T_A = 150^\circ$ C
t_{rr}	Reverse Recovery Time		3.0	μ s	$I_F = 10$ mA, $V_r = 3.5$ V, $R_L = 1.0$ k Ω
C	Capacitance		8.0	pF	$V_R = 0$, $f = 1.0$ MHz
BV	Breakdown Voltage	150		V	$I_R = 100$ μ A

NOTES:

1. The maximum ratings are limiting values above which life or satisfactory performance may be impaired.
2. These are steady state limits. The factory should be consulted on applications involving pulsed or low duty-cycle operation.
3. 1N3595 and IN6099 are electrically and mechanically identical.
4. For product family characteristic curves, refer to Chapter 4, D2.

1N3600 • 1N4150 • 1N4450

HIGH CONDUCTANCE ULTRA FAST DIODES

DIFFUSED SILICON PLANAR EPITAXIAL

- t_{rr} ... 4.0 ns (MAX)
- V_F ... 1.0 V (MAX) @ 200 mA

ABSOLUTE MAXIMUM RATINGS (Note 1)

Temperatures

Storage Temperature Range	-65°C to +200°C
Max Junction Operating Temperature	+175°C
Lead Temperature	+260°C

Power Dissipation (Note 2)

Max Total Power Dissipation at 25°C Ambient	500 mW
Linear Derating Factor (from 25°C)	3.33 mW / °C

Maximum Voltages and Currents

	1N3600	1N4150	1N4450
WIV Working Inverse Voltage	50 V	50 V	30 V
I_O Average Rectified Current	200 mA	200 mA	200 mA
I_F DC Forward Current	400 mA	400 mA	400 mA
i_f Recurrent Peak Forward Current	600 mA	600 mA	600 mA
i_f (surge) Peak Forward Surge Current			
Pulse Width = 1.0 s	1.0 A	1.0 A	1.0 A
Pulse Width = 1.0 μ s	4.0 A	4.0 A	4.0 A

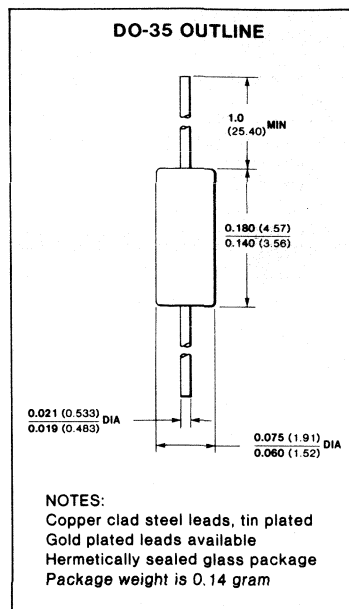

3

ELECTRICAL CHARACTERISTICS (25°C Ambient Temperature unless otherwise noted)

SYMBOL	CHARACTERISTIC	1N3600 1N4150		1N4450		UNITS	TEST CONDITIONS
		MIN	MAX	MIN	MAX		
BV	Breakdown Voltage	75		40		V V	$I_R = 5.0 \mu A$ $I_R = 5.0 \mu A$
I_R	Reverse Current		100 100		50 50	nA nA μA μA	$V_R = 50 V$ $V_R = 30 V$ $V_R = 50 V, T_A = 150^\circ C$ $V_R = 30 V, T_A = 150^\circ C$
V_F	Forward Voltage	0.54 0.66 0.76 0.82 0.87	0.62 0.74 0.86 0.92 1.0	0.42 0.52 0.64 0.80	0.54 0.64 0.76 0.92 1.0	V V V V V	$I_F = 0.1 mA$ $I_F = 1.0 mA$ $I_F = 10 mA$ $I_F = 50 mA$ $I_F = 100 mA$ $I_F = 200 mA$
C	Capacitance		2.5		4.0	pF	$V_R = 0, f = 1.0 MHz$
t_{rr}	Reverse Recovery Time (Note 3)		4.0 6.0		4.0	ns ns ns	$I_f = I_r = 10 mA$ to 200 mA, $R_L = 100 \Omega$ $I_f = I_r = 10 mA, R_L = 100 \Omega$ $I_f = I_r = 200 mA$ to 400 mA, $R_L = 100 \Omega$
t_{fr}	Forward Recovery Time		10			ns	$I_f = 200 mA, t_r = 0.4 ns,$ $V_{fr} = 1.0 V$

NOTES:

1. Maximum ratings are limiting values above which life or satisfactory performance may be impaired.
2. These are steady state limits. The factory should be consulted on applications involving pulsed or low duty-cycle operation.
3. Recovery to 0.1 I_r .
4. For family characteristic curves, refer to Chapter 4, D4.

1N4001 • 1N4007

1 A SILICON RECTIFIERS

- GLASS PACKAGE
- 1000 V RATING (1N4007)

ABSOLUTE MAXIMUM RATINGS (Note 1)

Temperatures

Storage Temperature Range	-65°C to +175°C
Maximum Junction Operating Temperature	+175°C
Lead Temperature	+260°C

Maximum Voltages and Currents

V_{RRM}	Peak Repetitive Reverse Voltage	1N4001	50 V
V_{RWM}	Working Peak Reverse Voltage	1N4002	100 V
V_R	DC Blocking Voltage	1N4003	200 V
		1N4004	400 V
		1N4005	600 V
		1N4006	800 V
		1N4007	1000 V

		1N4001	35 V
		1N4002	70 V
		1N4003	140 V
		1N4004	280 V
		1N4005	420 V
		1N4006	560 V
		1N4007	700 V

$V_{R(rms)}$	rms Reverse Voltage		
		1N4001	1 A

I_O	Average Rectified Forward Current (Note 2)		1 A
-------	--	--	-----

I_{FSM}	Peak Forward Surge Current		30 A
-----------	----------------------------	--	------

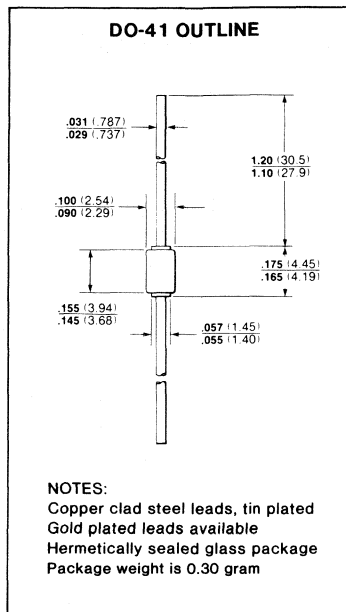

ELECTRICAL CHARACTERISTICS (25°C Ambient Temperature unless otherwise noted)

SYMBOL	CHARACTERISTIC	TYP	MAX	UNITS	TEST CONDITIONS
V_F	Forward Voltage	0.95	1.10	V	$I_O = 1.0$ A, $T_A = 75^\circ$ C
$V_{F(AV)}$	Average Forward Voltage	0.75	0.80	V	$I_F = 1$ A
V_{FM}	Peak Forward Voltage	1.40	1.60	V	$I_O = 1.0$ A
I_R	Reverse Current	0.05	10.0	μ A	Rated dc Voltage
		0.5	50	μ A	Rated dc Voltage, $T_A = 100^\circ$ C
$I_{R(AV)}$	Average Reverse Current	1.0	30	μ A	Rated V_R , $I_O = 1.0$ A
t_{rr}	Reverse Recovery Time (Note 3)	1.0		μ s	$I_f = 1.0$ A, $V_r = 30$ V

NOTES:

1. These are limiting values above which the serviceability of the rectifier may be impaired.
2. Derate Linearly above $T_A = 75^\circ$ C (Note 3).
3. For product family characteristic curves and test circuit, refer to Chapter 4, D16.

1N4009

ULTRA HIGH SPEED DIODE

DIFFUSED SILICON PLANAR

- t_{rr} ... 2 ns (MAX)
- BV ... 35 V (MIN) @ 5 μ A

ABSOLUTE MAXIMUM RATINGS (Note 1)

Temperatures

Storage Temperature Range	-65°C to +200°C
Maximum Junction Operating Temperature	+175°C
Lead Temperature	+260°C

Power Dissipation (Note 2)

Maximum Total Power Dissipation at 25°C Ambient	500 mW
Linear Power Derating Factor	3.33 mW/°C

Maximum Voltage and Current

WIV	Working Inverse Voltage	25 V
I_O	Average Rectified Current	100 mA
I_F	Continuous Forward Current	300 mA
i_f	Peak Repetitive Forward Current	400 mA
i_f (surge)	Peak Forward Surge Current	1.0 A
	Pulse Width = 1 s	4.0 A
	Pulse Width = 1 μ s	4.0 A

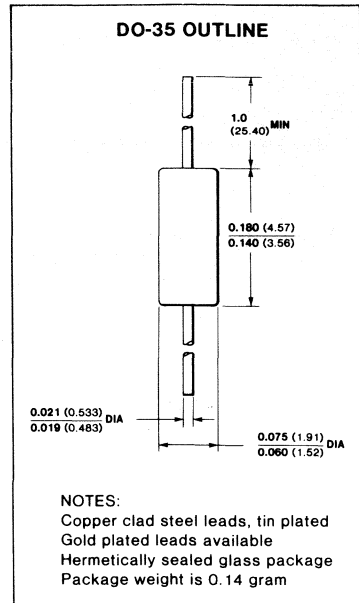

3

ELECTRICAL CHARACTERISTICS (25°C Ambient Temperature unless otherwise noted)

SYMBOL	CHARACTERISTIC	MIN	MAX	UNITS	TEST CONDITIONS
V_F	Forward Voltage		1.0	V	$I_F = 30$ mA
I_R	Reverse Current		0.1 100	μ A μ A	$V_R = 25$ V $V_R = 25$ V, $T_A = 150^\circ$ C
BV	Breakdown Voltage	35		V	$I_R = 5.0$ μ A
t_{rr}	Reverse Recovery Time		4.0 2.0	ns ns	$I_f = I_r = 10$ mA (Note 3) $I_f = 10$ mA, $V_r = 6.0$ V, $R_L = 100$ Ω
C	Capacitance		4.0	pF	$V_R = 0, f = 1.0$ MHz

- NOTES:**
1. These ratings are limiting values above which the serviceability of the diode may be impaired.
 2. These are steady state limits. The factory should be consulted on applications involving pulsed or low duty-cycle operation.
 3. Recovery to 1.0 mA.
 4. For product family characteristic curves, refer to Chapter 4, D4

1N4099 – 1N4121 • 1N4620 – 1N4627

500 mW SILICON ZENER DIODES

- 250 μ A TEST CURRENT
- MAXIMUM NOISE DENSITY SPECIFIED

ABSOLUTE MAXIMUM RATINGS (Note 1)

Temperatures

Storage Temperature Range	-65°C to +200°C
Maximum Junction Operating Temperature	+200°C
Lead Temperature	+260°C

Power Dissipation (Note 2)

Maximum Total Power Dissipation at 25°C Ambient	500 mW
Linear Power Derating Factor (from 25°C)	2.85 mW/°C

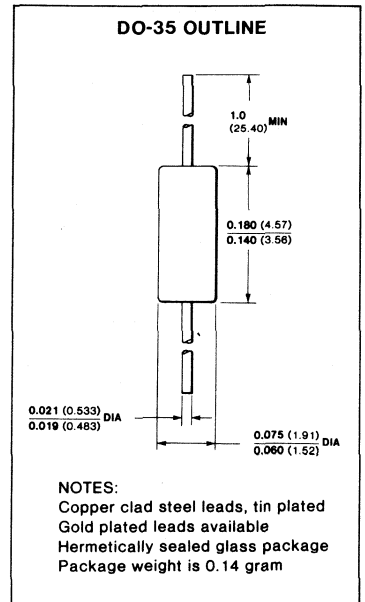

ELECTRICAL CHARACTERISTICS (at 25°C Ambient)

SYMBOL	V_Z	Z_Z	I_R	V_{RT}	N_D	I_{ZM}
CHARACTERISTIC	Nominal Zener Voltage @ $I_Z = 250 \mu$ A (Note 3)	Maximum Zener Impedance @ $I_Z = 250 \mu$ A	Maximum Reverse Current @ V_{RT}	Test Voltage	Maximum Noise Density @ $I_Z = 250 \mu$ A (Note 5)	Maximum Zener Current (Note 4)
UNIT	V	Ω	μ A	V	μ V / $\sqrt{\text{Hz}}$	mA
1N4620	3.3	1650	7.5	1.5	1.0	130
1N4621	3.6	1700	7.5	2.0	1.0	119
1N4622	3.9	1650	5.0	2.0	1.0	110
1N4623	4.3	1600	4.0	2.0	1.0	99
1N4624	4.7	1550	10.0	3.0	1.0	91
1N4625	5.1	1500	10.0	3.0	2.0	84
1N4626	5.6	1400	10.0	4.0	4.0	76
1N4627	6.2	1200	10.0	5.0	5.0	68

NOTES:

1. These ratings are limiting values above which life or satisfactory performance may be impaired.
2. These are steady-state limits. The factory should be consulted on applications involving pulsed or low duty-cycle operation.
3. Tolerance on the nominal Zener voltage is $\pm 5\%$.
4. Maximum Zener current rating is based on the maximum Zener voltage, taking account of Zener impedance and tolerance.
5. $V_F = 1.0$ V max at $I_F = 200$ mA for all types.
6. For product family characteristic curves, refer to Chapter 4, D13.

FAIRCHILD • ZENER DIODES

ELECTRICAL CHARACTERISTICS (at 25°C Ambient)

SYMBOL	V _Z	Z _Z	I _R	V _{RT}	N _D	I _{ZM}
CHARACTERISTICS	Nominal Zener Voltage @I _Z = 250 μA (Note 3)	Maximum Zener Impedance @I _Z = 250 μA	Maximum Reverse Current @V _{RT}	Test Voltage	Maximum Noise Density @I _Z = 250 μA (Note 5)	Maximum Zener Current (Note 4)
UNIT	V	Ω	μA	V	μV / √Hz	mA
IN4099	6.8	200	10.0	5.2	40	63
IN4100	7.5	200	10.0	5.7	40	57
IN4101	8.2	200	1.0	6.3	40	52
IN4102	8.7	200	1.0	6.7	40	49
IN4103	9.1	200	1.0	7.0	40	47
IN4104	10.0	200	1.0	7.6	40	42
IN4105	11.0	200	0.05	8.5	40	39
IN4106	12.0	200	0.05	9.2	40	35
IN4107	13.0	200	0.05	9.9	40	32
IN4108	14.0	1650	0.05	10.7	40	31
IN4109	15.0	1700	0.05	11.4	40	28
IN4110	16.0	1650	0.05	12.2	40	26
IN4111	17.0	1600	0.05	13.0	40	25
IN4112	18.0	1550	0.05	13.7	40	23
IN4113	19.0	1500	0.05	14.5	40	22
IN4114	20.0	1400	0.01	15.2	40	21
IN4115	22.0	1200	0.01	16.8	40	19
IN4116	24.0	200	0.01	18.3	40	17
IN4117	25.0	200	0.01	19.0	40	16
IN4118	27.0	200	0.01	20.5	40	15
IN4119	28.0	200	0.01	21.3	40	14
IN4120	30.0	200	0.01	22.8	40	13
IN4121	33.0	200	0.01	25.1	40	13

3

1N4151 • 1N4152 • 1N4153 • 1N4154

HIGH SPEED DIODES

SILICON PLANAR EPITAXIAL

- C_{j} ... 4 pF (MAX)
- t_{rr} ... 2 ns (MAX) @ 10 mA, -6 V, 100 Ω .

ABSOLUTE MAXIMUM RATINGS (Note 1)

Temperatures

Storage Temperature Range	-65°C to +200°C
Maximum Junction Operating Temperature	+175°C
Lead Temperature	+260°C

Power Dissipation (Note 2)

Maximum Total Power Dissipation at 25°C Ambient	500 mW
Linear Power Derating Factor	3.33 mW / °C

Maximum Voltage and Currents

WIV	Working Inverse Voltage	1N4151 50 V	1N4153 50 V
		1N4152 30 V	1N4154 25 V
I_O	Average Rectified Current		100 mA
I_F	Continuous Forward Current		300 mA
i_f	Peak Repetitive Forward Current		400 mA
i_f (surge)	Peak Forward Surge Current		4.0 A
	Pulse Width = 1 s		1.0 A
	Pulse Width = 1 μ s		4.0 A

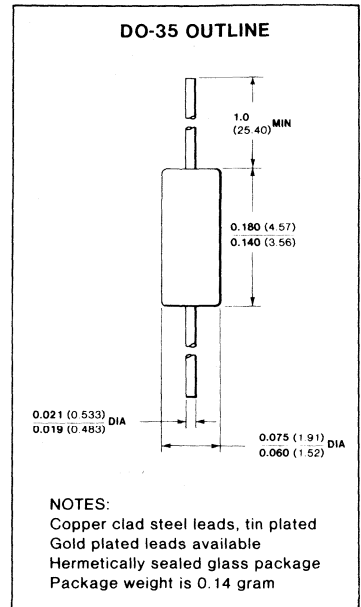

ELECTRICAL CHARACTERISTICS (25°C Ambient Temperature unless otherwise noted)

SYMBOL	CHARACTERISTIC	MIN	MAX	UNITS	TEST CONDITIONS
V_F	Forward Voltage 1N4154 1N4151 1N4152 & 1N4153		1.0	V	$I_F = 30$ mA
			1.0	V	$I_F = 50$ mA
		0.49	0.55	V	$I_F = 0.1$ mA
		0.53	0.59	V	$I_F = 0.25$ mA
		0.59	0.67	V	$I_F = 1.0$ mA
		0.62	0.70	V	$I_F = 2.0$ mA
		0.70	0.81	V	$I_F = 10$ mA
		0.74	0.88	V	$I_F = 20$ mA
I_R	Reverse Current 1N4154 1N4153 } 1N4151 } 1N4152		0.1	μ A	$V_R = 25$ V
			100	μ A	$V_R = 25$ V, $T_A = 150^\circ$ C
			0.05	μ A	$V_R = 50$ V
			50	μ A	$V_R = 50$ V, $T_A = 150^\circ$ C
			0.05	μ A	$V_R = 30$ V
	50	μ A	$V_R = 30$ V, $T_A = 150^\circ$ C		
BV	Breakdown Voltage 1N4154 1N4153 } 1N4151 } 1N4152	35		V	$I_R = 5.0$ μ A
		75		V	$I_R = 5.0$ μ A
		40		V	$I_R = 5.0$ μ A
				V	$I_R = 5.0$ μ A
t_{rr}	Reverse Recovery Time		4.0	ns	$I_f = 10$ mA, $I_r = 10$ mA (Note 3)
			2.0	ns	$I_f = 10$ mA $V_r = -6.0$ V, $R_L = 100$ Ω
C	Capacitance		4.0	pF	$V_R = 0$, $f = 1.0$ MHz

NOTES:

1. The maximum ratings are limiting values above which satisfactory performance may be impaired.
2. These are steady state limits. The factory should be consulted in applications involving pulsed or low duty cycle operation.
3. Recovery to 1.0 mA.
4. For product family characteristic curves, refer to Chapter 4, D4.

1N4306 • 1N4307

PAIR AND QUAD ASSEMBLIES DIODES

OF SILICON PLANAR EPITAXIAL

- $\Delta V_F \dots 10 \text{ mV (MAX)}$
- $C \dots 2.0 \text{ pF (MAX)}$

GENERAL DESCRIPTION

The 1N4306 and 1N4307 are epoxy encapsulated assemblies of two and four glass diodes respectively. They feature tightly matched forward voltages over broad current and temperature ranges.

ABSOLUTE MAXIMUM RATINGS (Note 1)

Temperatures

Storage Temperature Range	-65°C to +150°C
Maximum Junction Operating Temperature	+150°C
Lead Temperature	+260°C

Power Dissipation (Note 2)

Maximum Total Power Dissipation at 25°C Ambient	
Each Diode	250 mW
Encapsulated Package	500 mW
Linear Derating Factor (from 25°C)	
Each Diode	2.0 mW/°C
Encapsulated Package	4.0 mW/°C

Maximum Voltage and Currents

WIV	Working Inverse Voltage	50 V
I_O	Average Rectified Current	200 mA
I_F	Continuous Forward Current	300 mA
i_f	Recurrent Peak Forward Current	600 mA
$i_f(\text{surge})$	Peak Forward Surge Current	
	Pulse Width = 1.0 s	1.0 A
	Pulse Width = 1.0 μs	4.0 A

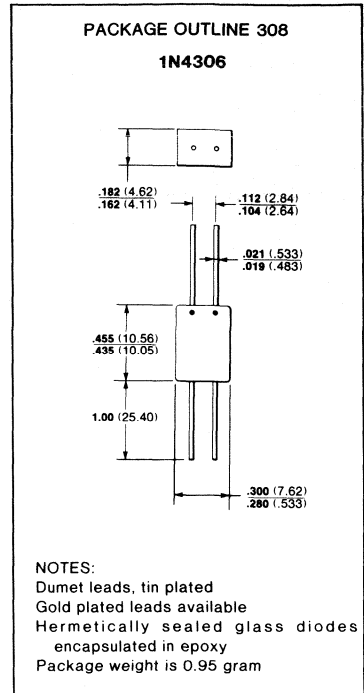

ELECTRICAL CHARACTERISTICS (25°C Ambient Temperature unless otherwise noted)

SYMBOL	CHARACTERISTIC	MIN	MAX	UNITS	TEST CONDITIONS
BV	Breakdown Voltage	75		V	$I_R = 5.0 \text{ mA}$
I_R	Reverse Current		50	nA	$V_R = 50 \text{ V}$
			50	nA	$V_R = 50 \text{ V}, T_A = 150^\circ\text{C}$
V_F	Forward Voltage	0.75	1.00	V	$I_F = 50 \text{ mA}$
		0.67	0.81	V	$I_F = 10 \text{ mA}$
		0.56	0.67	V	$I_F = 1.0 \text{ mA}$
		0.44	0.55	V	$I_F = 100 \mu\text{A}$
C	Capacitance		2.0	pF	$V_R = 0, f = 1 \text{ MHz}$
t_{rr}	Reverse Recovery Time		4.0	ns	$I_f = I_r = 10 \text{ mA}, R_L = 100\Omega$ Recovery to 1 mA
ΔV_F	Forward Voltage Match (Note 4)		10	mV	$I_F = 0.1 \text{ to } 10 \text{ mA}$ $T_A = -55^\circ\text{C to } +125^\circ\text{C}$
			20	mV	$I_F = 10 \text{ to } 50 \text{ mA}$ $T_A = -55^\circ\text{C to } +125^\circ\text{C}$

NOTES:

1. These are limiting values above which life or satisfactory performance may be impaired.
2. These are steady state limits. The factory should be consulted on applications involving pulsed or low duty-cycle operation.
3. For product family characteristic curves, refer to Chapter 4, D4.
4. For test circuits, refer to Chapter 4, D18.

FAIRCHILD • PAIR AND QUAD ASSEMBLIES

PACKAGE OUTLINES 310

1N4307

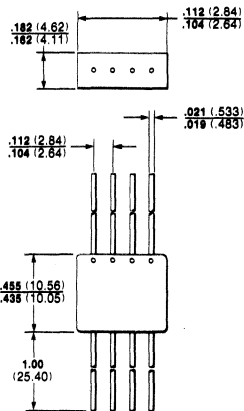

NOTES:

- Dumet leads, tin plated
- Gold plated leads available
- Hermetically sealed glass diodes encapsulated in epoxy
- Package weight is 1.5 grams

IN4728 – IN4752

1 W SILICON ZENER DIODES

ABSOLUTE MAXIMUM RATINGS (Note 1)

Temperatures

Storage Temperature Range	-65°C to +200°C
Maximum Junction Operating Temperature	+200°C
Lead Temperature	+260°C

Power Dissipation (Note 2)

Maximum Total Dissipation at 50°C Ambient	1 W
Linear Power Derating Factor (from 50°C)	6.67 mW / °C
Maximum Surge Power (Note 8)	10 W

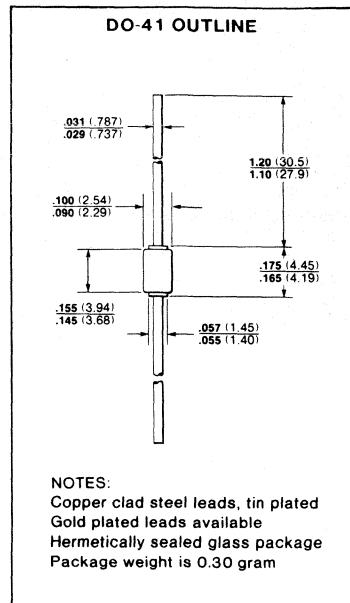

3

ELECTRICAL CHARACTERISTICS (25°C Ambient)

SYMBOL	V _Z	Z _Z	I _{ZT}	Z _{ZK}	I _{ZK}	I _R	V _{RT}	I _{ZM}	I _Z (surge)
CHARACTERISTICS	Nominal Zener Voltage (Note 4) @I _{ZT}	Maximum Zener Impedance (Note 5) @I _{ZT}	Test Current	Maximum Zener Knee Impedance (Note 5) @I _{ZK}	Test Current	Maximum Reverse Current @V _{RT}	Test Voltage	Maximum Zener Current (Note 6)	Maximum Zener Surge Current (Note 3)
UNIT	V	Ω	mA	Ω	mA	μA	V	mA	mA
IN4728	3.3	10.0	76.0	400	1.0	100	1.0	276	1380
IN4729	3.6	10.0	69.0	400	1.0	100	1.0	252	1260
IN4730	3.9	9.0	64.0	400	1.0	50	1.0	234	1190
IN4731	4.3	9.0	58.0	400	1.0	10	1.0	217	1070
IN4732	4.7	8.0	53.0	500	1.0	10	1.0	193	970
IN4733	5.1	7.0	49.0	550	1.0	10	1.0	178	890
IN4734	5.6	5.0	45.0	600	1.0	10	2.0	162	810
IN4735	6.2	2.0	41.0	700	1.0	10	3.0	146	730
IN4736	6.8	3.5	37.0	700	1.0	10	4.0	133	660
IN4737	7.5	4.0	34.0	700	0.5	10	5.0	121	605
IN4738	8.2	4.5	31.0	700	0.5	10	6.0	110	550
IN4739	9.1	5.0	28.0	700	0.5	10	7.0	100	500
IN4740	10.0	7.0	25.0	700	0.25	10	7.6	91	454

NOTES:

1. These ratings are limiting values above which the serviceability of the diode may be impaired.
2. These are steady state limits. The factory should be consulted on applications involving pulsed or low duty-cycle operation.
3. Non-recurrent square wave, PW = 8.3 ms, superimposed on Zener test current, I_{ZT}.
4. Type numbers without suffix have ± 10% tolerance on nominal V_Z. Type numbers with suffix A have ± 5% tolerance on nominal V_Z.
5. The Zener impedances Z_Z and Z_{ZK} are derived by superimposing a 80 Hz signal on test currents I_{ZT} and I_{ZK}, having an RMS value of 10% of the d.c. value of I_{ZT} and I_{ZK} respectively.
6. Maximum Zener Current (I_{ZM}) is based on the maximum Zener voltage of a 10% tolerance unit.
7. V_F = 1.2 V (max) @ I_F = 200 mA for all types. Non-recurrent square wave, PW = 8.3 ms, T_A = 55°C.
8. Non-recurrent square wave. PW = 8.3 ms, T_A = 55°C
9. For product family characteristic curves, refer to Chapter 4, D14.

FAIRCHILD • 1 W ZENER DIODES

ELECTRICAL CHARACTERISTICS (25°C Ambient)

SYMBOL	V _Z	Z _Z	I _{ZT}	Z _{ZK}	I _{ZK}	I _R	V _{RT}	I _{ZM}	I _Z (surge)
CHARACTERISTIC	Nominal Zener Voltage (Note 4) @I _{ZT}	Maximum Zener Impedance (Note 5) @I _{ZT}	Test Current	Maximum Zener Knee Impedance (Note 5) @I _{ZK}	Test Current	Maximum Reverse Current @V _{RT}	Test Voltage	Maximum Zener Current (Note 6)	Maximum Zener Surge Current (Note 3)
UNIT	V	Ω	mA	Ω	mA	μA	V	mA	mA
IN4741	11.0	8.0	23.0	700	0.25	5.0	8.4	83	414
IN4742	12.0	9.0	21.0	700	0.25	5.0	9.1	76	380
IN4743	13.0	10.0	19.0	700	0.25	5.0	9.9	69	344
IN4744	15.0	14.0	17.0	700	0.25	5.0	11.4	61	304
IN4745	16.0	16.0	15.5	700	0.25	5.0	12.2	57	285
IN4746	18.0	20.0	14.0	750	0.25	5.0	13.7	50	250
IN4747	20.0	22.0	12.5	750	0.25	5.0	15.2	45	225
IN4748	22.0	23.0	11.5	750	0.25	5.0	16.7	41	205
IN4749	24.0	25.0	10.5	750	0.25	5.0	18.2	38	190
IN4750	27.0	35.0	9.5	750	0.25	5.0	20.6	34	170
IN4751	30.0	40.0	8.5	1000	0.25	5.0	22.8	30	150
IN4752	33.0	45.0	7.5	1000	0.25	5.0	25.1	27	135

1N4933 – 1N4937

FAST RECOVERY 1 A SILICON RECTIFIERS

- t_{rr} ... 200 ns (MAX)
- GLASS PACKAGE

ABSOLUTE MAXIMUM RATINGS

Temperatures

Storage Temperature Range	-65°C to +175°C
Maximum Junction Operating Temperature	+150°C
Lead Temperature	+260°C

Maximum Voltages and Currents

V_{RRM}	Peak Repetitive Reverse Voltage	1N4933	50 V
V_{RWM}	Working Peak Reverse Voltage	1N4934	100 V
V_R	DC Blocking Voltage	1N4935	200 V
		1N4936	400 V
		1N4937	600 V
		1N4933	35 V
		1N4934	70 V
$V_R(\text{rms})$	rms Reverse Voltage	1N4935	140 V
		1N4936	280 V
		1N4937	420 V
I_O	Average Rectified Forward Current (Note 2)		1 A
I_{FSM}	Peak Forward Surge Current		30 A

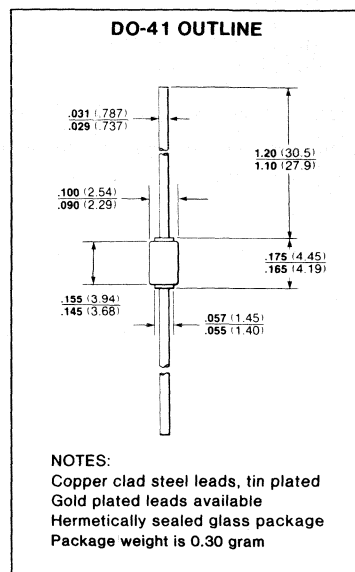

3

ELECTRICAL CHARACTERISTICS (25°C Ambient Temperature unless otherwise noted)

SYMBOL	CHARACTERISTIC	TYP	MAX	UNITS	TEST CONDITIONS
V_F	Forward Voltage	1.1	1.2	V	$I_O = 1.0 \text{ A}$, $T_A = 75^\circ\text{C}$ $I_F = 1 \text{ A}$
V_F	Instantaneous Forward Voltage	0.95	1.2	V	
I_R	Reverse Current	0.10 1.0	5.0 100	μA μA	Rated dc Voltage Rated dc Voltage, $T_A = 100^\circ\text{C}$
t_{rr}	Reverse Recovery Time (Note 3)	150	200	ns	$I_F = 1.0 \text{ A}$, $V_R = 30 \text{ V}$
I_{RM}	Reverse Recovery Current (Note 3)	1.5	2.0	A	$I_F = 1.0 \text{ A}$, $V_R = 30 \text{ V}$

NOTES:

1. These are limiting values above which the serviceability of the rectifier may be impaired.
2. Derate linearly above $T_A = 75^\circ\text{C}$ (Note 3).
3. For product family characteristic curves and test circuit, refer to Chapter 4, D17.

IN5226 • IN5257

500 mW SILICON ZENER DIODES

ABSOLUTE MAXIMUM RATINGS (Note 1)

Temperatures

Storage Temperature Range	-65°C to +200°C
Maximum Junction Operating Temperature	+200°C
Lead Temperature	+260°C

Power Dissipation (Note 2)

Maximum Total Power Dissipation at 75°C Ambient	500 mW
Linear Power Derating Factor (from 75°C)	4.0 mW/°C
Maximum Surge Power (Note 3)	10 W

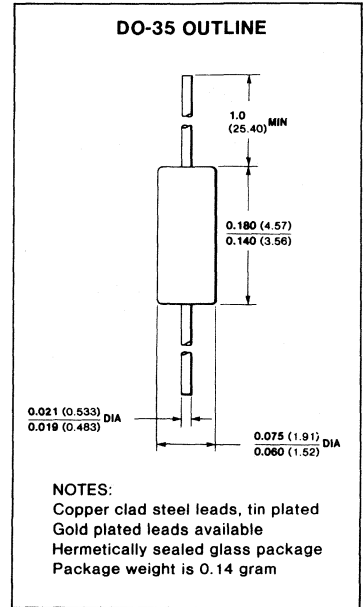

ELECTRICAL CHARACTERISTICS (25°C Ambient unless otherwise noted)

SYMBOL	V _Z	Z _Z	I _{ZT}	Z _{ZK}	I _R		V _{RT}		TC	
					Maximum Reverse Current @ V _{RT}		Test Voltage			Maximum Temperature Coefficient of V _Z (Note 6)
					± 20% V _Z Tolerance	± 10, 5, 2, 1% V _Z Tolerance	± 20, 10% V _Z Tolerance	± 5, 2, 1% V _Z Tolerance		
CHARACTERISTIC	Nominal Zener Voltage (Note 4) @ I _{ZT}	Maximum Zener Impedance (Note 5) @ I _{ZT}	Test Current	Maximum Zener Knee Impedance (Note 5) @ I _{ZK} = 0.25 mA	μA	μA	V	V	% / °C	
UNIT	V	Ω	mA	Ω	μA	μA	V	V	% / °C	
IN5226	3.3	28	20	1600	100	25	0.95	1.0	-0.070	
IN5227	3.6	24	20	1700	100	15	0.95	1.0	-0.065	
IN5228	3.9	23	20	1900	75	10	0.95	1.0	-0.060	
IN5229	4.3	22	20	2000	50	5.0	0.95	1.0	±0.055	
IN5230	4.7	19	20	1900	50	5.0	1.9	2.0	±0.030	
IN5231	5.1	17	20	1600	50	5.0	1.9	2.0	±0.030	
IN5232	5.6	11	20	1600	50	5.0	2.9	3.0	+0.038	
IN5233	6.0	7.0	20	1600	50	5.0	3.3	3.5	+0.038	
IN5234	6.2	7.0	20	1000	50	5.0	3.8	4.0	+0.045	
IN5235	6.8	5.0	20	750	30	3.0	4.8	5.0	+0.050	
IN5236	7.5	6.0	20	500	30	3.0	5.7	6.0	+0.058	
IN5237	8.2	8.0	20	500	30	3.0	6.2	6.5	+0.062	
IN5238	8.7	8.0	20	600	30	3.0	6.2	6.5	+0.065	
IN5239	9.1	10	20	600	30	3.0	6.7	7.0	+0.068	
IN5240	10.0	17	20	600	30	3.0	7.6	8.0	+0.075	
IN5241	11.0	22	20	600	30	2.0	8.0	8.4	+0.076	

FAIRCHILD • 500 mW ZENER DIODES

ELECTRICAL CHARACTERISTICS (25°C Ambient unless otherwise noted)

SYMBOL	V _Z	Z _Z	I _{ZT}	Z _{ZK}	I _R		V _{RT}		TC
	Nominal Zener Voltage (Note 4) @I _{ZT}	Maximum Zener Impedance (Note 5) @I _{ZT}	Test Current	Maximum Zener Knee Impedance (Note 5) @ I _{ZK} = 0.25 mA	Maximum Reverse Current @ V _{RT}		Test Voltage		Maximum Temperature Coefficient of V _Z (Note 6)
					±20% V _Z Tolerance	±10, 5, 2, 1% V _Z Tolerance	±20, 10% V _Z Tolerance	±5, 2, 1% V _Z Tolerance	
UNIT	V	Ω	mA	Ω	μA	μA	V	V	%/°C
IN5242	12.0	30	20	600	10	1.0	8.7	9.1	+0.077
IN5243	13.0	13	9.5	600	10	0.5	9.4	9.9	+0.079
IN5244	14.0	15	9.0	600	10	0.1	9.5	10.0	+0.082
IN5245	15.0	18	8.5	600	10	0.1	10.5	11.0	+0.082
IN5246	16.0	17	7.8	600	10	0.1	11.4	12.0	+0.083
IN5247	17.0	19	7.4	600	10	0.1	12.4	13.0	+0.084
IN5248	18.0	21	7.0	600	10	0.1	13.3	14.0	+0.085
IN5249	19.0	23	6.6	600	10	0.1	13.3	14.0	+0.086
IN5250	20.0	25	6.2	600	10	0.1	14.3	15.0	+0.086
IN5251	22.0	29	5.6	600	10	0.1	16.2	17.0	+0.087
IN5252	24.0	33	5.2	600	10	0.1	17.1	18.0	+0.088
IN5253	25.0	35	5.0	600	10	0.1	18.1	19.0	+0.089
IN5254	27.0	41	4.6	600	10	0.1	20.0	21.0	+0.090
IN5255	28.0	44	4.5	600	10	0.1	20.0	21.0	+0.091
IN5256	30.0	49	4.2	600	10	0.1	22.0	23.0	+0.091
IN5257	33.0	58	3.8	700	10	0.1	24.0	25.0	+0.092

NOTES:

1. These ratings are limiting values above which the serviceability of the diode may be impaired.
2. These are steady state limits. The factory should be consulted on applications involving pulsed or low duty-cycle operation.
3. Non-recurrent square wave, PW = 8.3 ms, T_A = 55°C.
4. Type numbers without suffix have ±20% tolerance on nominal V_Z.
 Type numbers with suffix A have ±10% tolerance on nominal V_Z.
 Type numbers with suffix B have ±5% tolerance on nominal V_Z.
 Type numbers with suffix C have ±2% tolerance on nominal V_Z.
 Type numbers with suffix D have ±1% tolerance on nominal V_Z.
5. The Zener impedances Z_Z and Z_{ZK} are derived by superimposing a 60 Hz signal on test currents I_{ZT} and I_{ZK}, having an rms value of 10% of the dc value of I_{ZT} and I_{ZK} respectively.
6. Maximum temperature coefficients apply to 10, 5, 2 and 1% tolerance types only and are measured under the following conditions:
 IN5228A, B, C, D through IN5242A, B, C, D: I_Z = 7.5 mA, T₁ = 25°C, T₂ = 125°C.
 IN5242A, B, C, D through IN5257A, B, C, D: I_Z = I_{ZT}, T₁ = 25°C, T₂ = 125°C.
7. V_F = 1.1V (maximum) @ I_F = 200 mA for all types.
8. For product family characteristic curves, refer to Chapter 4, D13.

3

1N5282

HIGH CONDUCTANCE ULTRA FAST DIODE

DIFFUSED SILICON PLANAR EPITAXIAL

- BV... 80 V (MIN) @ 5.0 μ A
- C... 2.5 pF @ $V_R = 0$ V, $f = 1.0$ MHz
- t_{rr} ... 4.0 ns @ $I_f = I_r = 10$ mA to 200 mA

ABSOLUTE MAXIMUM RATINGS (Note 1)

Temperatures

Storage Temperature Range	-65°C to +200°C
Maximum Junction Operating Temperature	+175°C
Lead Temperature	+260°C

Power Dissipation (Note 2)

Maximum Total Dissipation at 25° Ambient	500 mW
Linear Derating Factor (from 25°C)	3.33 mW/°C

Maximum Voltage and Currents

WIV	Working Inverse Voltage	55 V
I_O	Average Rectified Current	200 mA
I_F	Continuous Forward Current	300 mA
I_f (surge)	Peak Forward Surge Current	
	Pulse Width = 1.0 s	1.0 A
	Pulse Width = 1.0 μ s	4.0 A

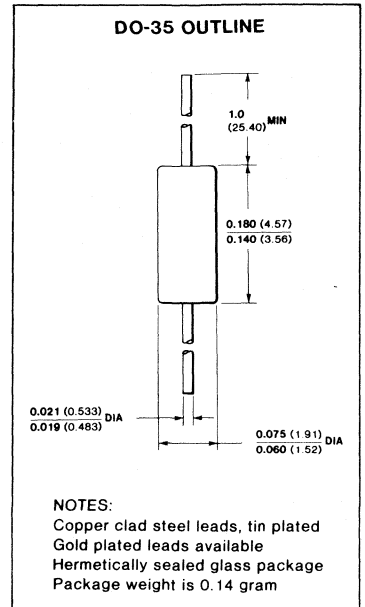

ELECTRICAL CHARACTERISTICS (25°C Ambient Temperature unless otherwise noted)

SYMBOL	CHARACTERISTIC	MIN	MAX	UNITS	TEST CONDITIONS
V_F	Forward Voltage	1.05	1.30	V	$I_F = 500$ mA
		0.92	1.10	V	$I_F = 300$ mA
		0.80	0.90	V	$I_F = 100$ mA
		0.67	0.725	V	$I_F = 10$ mA
		0.55	0.60	V	$I_F = 1.0$ mA
		0.45	0.49	V	$I_F = 0.1$ mA
I_R	Reverse Current		100	nA	$V_R = 55$ V
			100	μ A	$V_R = 55$ V, $T_A = 150^\circ$ C
BV	Breakdown Voltage	80		V	$I_R = 5.0$ μ A
t_{rr}	Reverse Recovery Time (Note 3)		4.0	ns	$I_f = I_r = 10$ mA to 200 mA $R_L = 100 \Omega$
t_{rr}	Reverse Recovery Time		2.0	ns	$I_f = 10$ mA, $V_r = 6.0$ V
t_{fr}	Forward Recovery Time		10	ns	$I_f = 200$ mA (Note 4)
V_{pk}	Peak Forward Voltage		2.0	V	$I_f = 500$ mA (Note 5)
C	Capacitance		2.5	pF	$V_R = 0, f = 1.0$ MHz

NOTES:

1. The maximum ratings are limiting values above which life or satisfactory performance may be impaired.
2. These are steady-state limits. The factory should be consulted on applications involving pulsed or low duty-cycle operation.
3. Recovery to 0.1 I_r .
4. $t_r = 0.4$ ns, $V_r = 1.0$ V, pulse width = 100 ns; duty cycle $\leq 1\%$.
5. $t_r = 8.0$ ns, pulse width = 1.0 μ s; duty cycle $\leq 1\%$.
6. For product family characteristics curves, refer to Chapter 4, D4.

1N5768 • 1N5770 • 1N5772 • 1N5774

MONOLITHIC AIR ISOLATED DIODE ARRAYS

- BV ... 60 V @ 10 μ A
- I_R ... 100 nA @ 40 V
- V_R ... 1 V @ 100 mA

ABSOLUTE MAXIMUM RATINGS (Note 1)

Temperatures

Storage Temperature Range	-65°C to +200°C
Junction Operating Temperature Range	-65°C to +200°C

Maximum Power Dissipation

Maximum Total Dissipation at $T_A = 25^\circ\text{C}$	500 mW
Linear Derating Factor	4.0 mW/°C above 25°C

Maximum Currents

I_O	Average Rectified Current (each diode)	300 mA
	Linear Derating Factor	2.4 mA/°C above 25°C
I_{FSM}	Peak Forward Surge Current Pulse Width = 8.3 ms	500 mA

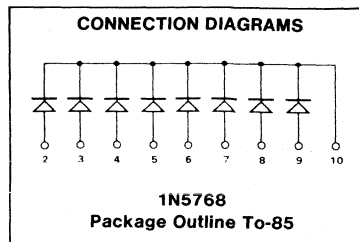

ELECTRICAL CHARACTERISTICS (25°C Ambient Temperature unless otherwise noted)

SYMBOL	CHARACTERISTIC	MIN	MAX	UNITS	TEST CONDITIONS
BV	Breakdown Voltage	60		V	$I_R = 10 \mu\text{A}$, Pulse Width = 100 μs , Duty Cycle $\leq 20\%$
V_F	Forward Voltage		1.0 1.5	V V	$I_F = 100 \text{ mA}$ $I_F = 500 \text{ mA}$, Pulse Width = 300 ns, Duty Cycle = 2%
V_{FX}	Forward Voltage		1.0	V	$I_F = 25 \text{ mA}$; $I_F = 25 \text{ mA}$ for each of the other Diodes in the Test Section (Note 3)
V_{FM}	Peak Forward Voltage		5.0	V	$I_F = 500 \text{ mA}$, Pulse Width = 150 ns, Duty Cycle $\leq 2\%$
I_R	Reverse Current		100 50	nA μA	$V_R = 40 \text{ V}$ $V_R = 40 \text{ V}$, $T_A = +150^\circ\text{C}$
I_{RX}	Reverse Current		10	μA	$V_R = 40 \text{ V}$, $I_F = 25 \text{ mA}$ for each of the other Diodes in the Test Section (Note 3)
I_{Ri}	Isolation Current 1N5772, 1N5774		0.8	μA	$V_R = 40 \text{ V}$ (Note 4)
C	Pin-to-Pin Capacitance (Note 2) 1N5768 1N5770, 1N5772, 1N5774		4.0 8.0	pF pF	$V_R = 0 \text{ V}$, $f = 1.0 \text{ MHz}$ $V_R = 0 \text{ V}$, $f = 1.0 \text{ MHz}$
t_{fr}	Forward Recovery Time (Note 5)		40	ns	$I_F = 500 \text{ mA}$, $R_S = 10 \Omega$, $V_{fr} = 1.8 \text{ V}$, $t_r = 15 \text{ ns Max}$
t_{rr}	Reverse Recovery Time (Note 5)		20	ns	$I_F = 200 \text{ mA}$, $I_r = 200 \text{ mA}$, $R_L = 100 \Omega$, $I_{rr} = 20 \text{ mA}$

NOTES:

1. The maximum ratings are limiting values above which life or satisfactory performance may be impaired.
2. This parameter is the total pin-to-pin capacitance measured across each diode. This does not necessarily represent actual diode capacitance since other diode interconnections can contribute additional capacitance.
3. Each common anode section and/or common cathode section tested separately.
4. The isolation current shall be measured between any two interconnect pins of adjacent parallel sets of diodes with all other pins open circuited.
5. For Product Family characteristic curves and Test Circuits, refer to Chapter 4, D15.

FAIRCHILD • DIODE ARRAYS

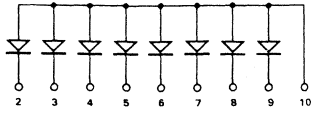

1N5770
Package Outline To-85

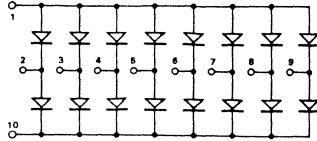

1N5772
Package Outline To-85

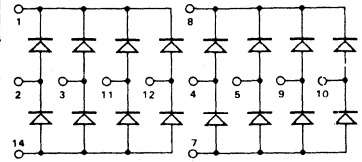

1N5774
Package Outline To-86

TO-85 OUTLINE

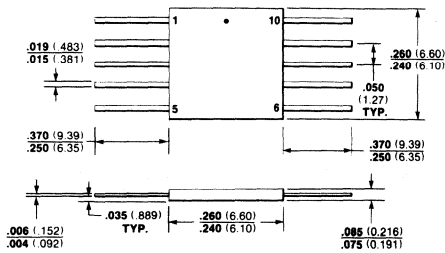

NOTES:
 Alloy 42 leads, tin plated
 Gold plated leads available
 Hermetically sealed ceramic package
 Dot or tab indicates lead 1
 Package weight is 0.26 gram

TO-86 OUTLINE

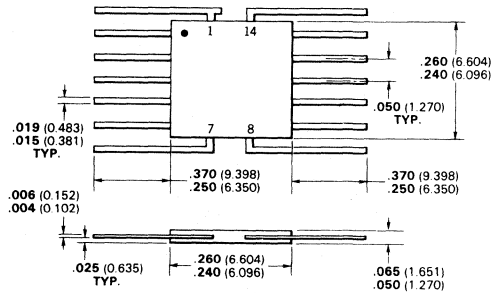

NOTES:
 Alloy 42 leads, tin plated
 Gold plated leads available
 Hermetically sealed ceramic package
 Dot or tab indicates lead 1
 Package weight is 0.27 gram

1N6100 • 1N6101

PLANAR AIR-ISOLATED MONOLITHIC DIODE ARRAYS

- C ... 3.0 pF (MAX)
- ΔV_F ... 10 mV (MAX) @ 10 μ A

ABSOLUTE MAXIMUM RATINGS (Note 1)

Temperatures

Storage Temperature Range	-55°C to +200°C
Maximum Junction Operating Temperature	+175°C
Lead Temperature	+260°C

Power Dissipation (Note 2)

Maximum Dissipation per Junction at 25°C Ambient	400 mW
Maximum Dissipation per Package at 25°C Ambient	600 mW
Linear Derating Factor (from 25°C) Junction	2.67 mW/°C
Package	4.0 mW/°C

Maximum Voltage and Currents

WIV	Working Inverse Voltage	65 V
I _F	Continuous Forward Current	350 mA
i _{f(surge)}	Peak Forward Surge Current	
	Pulse Width = 1.0 s	1.0 A
	Pulse Width = 1.0 μ s	2.0 A

CONNECTION DIAGRAM

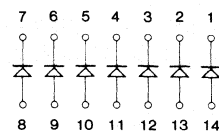

See Package Outlines

TO-86	1N6100
TO-116-2	1N6101

3

ELECTRICAL CHARACTERISTICS (25°C Ambient Temperature unless otherwise noted)

SYMBOL	CHARACTERISTIC	MIN	MAX	UNITS	TEST CONDITIONS
BV	Breakdown Voltage	75		V	I _R = 5.0 μ A
I _R	Reverse Current (Note 4)		25 50	nA μ A	V _R = 20 V V _R = 20 V, T _A = 150°C
V _F	Forward Voltage (Note 3)		1.0	V	I _F = 100 mA
V _{FM}	Peak Forward Voltage		5.0	V	I _F = 100 μ A, PW = 100 ns Duty Cycle \leq 2%
I _{RX}	Reverse Current (Note 5)		10	μ A	V _R = 40 V
V _{FX}	Forward Voltage (Note 5)		1.0	V	I _F = 25 mA
C	Capacitance		3.0	pF	V _R = 0, f = 1 MHz
t _{fr}	Forward Recovery Time (Note 6)		15	ns	I _f = 100 mA, R _S = 50 Ω V _{fr} = 1.1 V, t _r \leq 10 ns
t _{rr}	Reverse Recovery Time (Note 6)		5.0	ns	I _f = I _r = 10 mA I _{rr} = 1.0 mA, R _L = 100 Ω
ΔV_F	Forward Voltage Match (Note 6)		10	mV	I _F = 10 mA

NOTES

1. These ratings are limiting values above which life or satisfactory performance may be impaired.
2. These are steady state limits. The factory should be consulted on applications involving pulsed or low duty-cycle operation.
3. V_F is measured using an 8 ms pulse.
4. See Test Circuits (Note 6) for measurement of reverse current of an individual diode.
5. I_F = 25 mA for each of the other diodes in the array.
6. For product family characteristic curves and test circuits, refer to Chapter 4, D15.

FAIRCHILD • DIODE ARRAYS

TO-86 OUTLINE

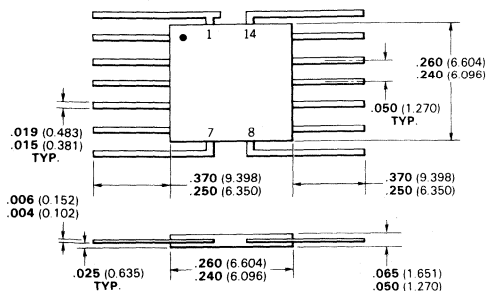

NOTES:

- Alloy 42 leads, tin plated
- Gold plated leads available
- Hermetically sealed ceramic package
- Dot or tab indicates lead 1
- Package weight is 0.27 gram

TO-116-2 OUTLINE

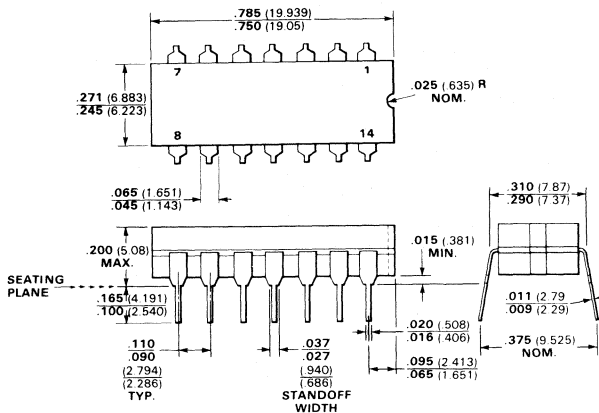

NOTES:

- Alloy 42 pins, tin plated
- Gold plated pins available
- Hermetically sealed ceramic package
- Pins are intended for insertion in hole rows on .300" (7.620) centers
- They are purposely shipped with "positive" misalignment to facilitate insertion
- Board-drilling dimensions should equal your practice for .020" (0.508) diameter pin
- Package weight is 2.0 grams

1S44

GENERAL PURPOSE SWITCHING DIODE

DIFFUSED SILICON PLANAR

- $BV \dots 50 \text{ V (MIN) @ } 100 \mu\text{A}$
- $t_{rr} \dots 8.0 \text{ ns (MAX)}$

ABSOLUTE MAXIMUM RATINGS (Note 1)

Temperatures

Storage Temperature Range	-65°C to +200°C
Maximum Junction Operating Temperature	+175°C
Lead Temperature	+260°C

Power Dissipation (Note 2)

Maximum Total Power Dissipation at 25°C Ambient	500 mW
Linear Power Derating Factor (from 25°C)	3.33 mW/°C

Maximum Voltage and Currents

WIV	Working Inverse Voltage	40 V
I_O	Average Rectified Current	100 mA
I_F	Continuous Forward Current	300 mA
i_f	Peak Repetitive Forward Current	400 mA
i_f (surge)	Peak Forward Surge Current	
	Pulse Width = 1 s	1.0 A
	Pulse Width = 1 μs	4.0 A

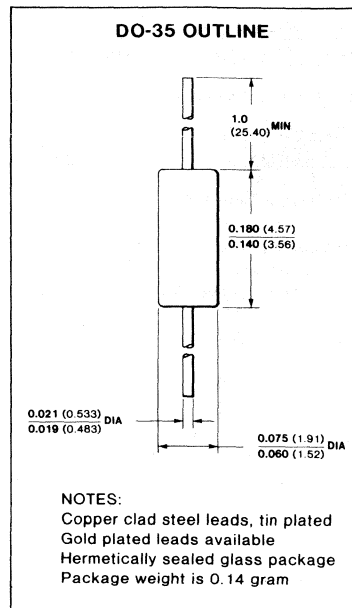

ELECTRICAL CHARACTERISTICS (25°C Ambient Temperature unless otherwise noted)

SYMBOL	CHARACTERISTIC	MIN	MAX	UNITS	TEST CONDITIONS
V_F	Forward Voltage	0.65 0.70	1.00 1.20	V	$I_F = 10 \text{ mA}$ $I_F = 30 \text{ mA}$
I_R	Reverse Current		50	nA	$V_R = 10 \text{ V}$
BV	Breakdown Voltage	50		V	$I_R = 100 \mu\text{A}$
C	Capacitance		4.0	pF	$V_R = 0, f = 1 \text{ MHz}$
Q_S	Stored Charge		120	pC	$I_F = 10 \text{ mA}, V_R = 10 \text{ V}$
t_{rr}	Reverse Recovery Time		8.0	ns	$I_f = I_r = 10 \text{ mA}$ Recovery to 1 mA

NOTES:

1. These ratings are limiting values above which the serviceability of the diode may be impaired.
2. These are steady state limits. The factory should be consulted on applications involving pulsed or low duty-cycle operation.
3. For product family characteristic curves, refer to Chapter 4, D4

1S920 • 1S921 • 1S922 • 1S923

GENERAL PURPOSE DIODES

DIFFUSED SILICON PLANAR

- $V_F \dots 1.2$ (MAX) @ 200 mA
- $I_R \dots 100$ nA (MAX) @ RATED WIV

ABSOLUTE MAXIMUM RATINGS (Note 1)

Temperatures

Storage Temperature Range	-65°C to +200°C
Maximum Junction Operating Temperature	+175°C
Lead Temperature	+260°C

Power Dissipation (Note 2)

Maximum Total Dissipation at 25°C Ambient	500 mW
Linear Derating Factor (from 25°C)	3.33 mW / °C

Maximum Voltage and Currents

		1S920	1S921	1S922	1S923
WIV	Working Inverse Voltage	50 V	100 V	150 V	200 V
	(-65°C to +100°C)				
I_O	Average Forward Current	200 mA	200 mA	200 mA	200 mA
	Recurent Peak Forward Current	600 mA	600 mA	600 mA	600 mA
i_f (surge)	Peak Forward Surge Current				
	Pulse Width = 1 s	1.0 A	1.0 A	1.0 A	1.0 A
	Pulse Width = 1 μ s	4.0 A	4.0 A	4.0 A	4.0 A

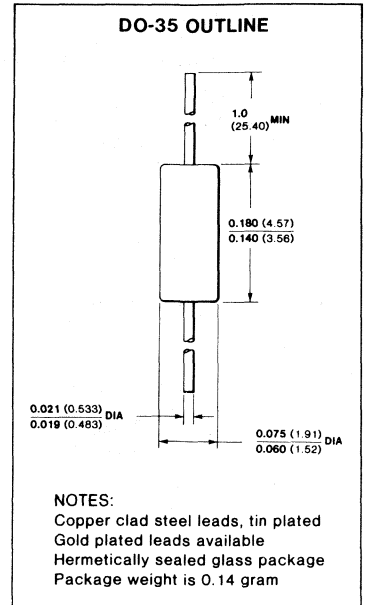

ELECTRICAL CHARACTERISTICS (25°C Ambient Temperature unless otherwise noted)

SYMBOL	CHARACTERISTIC	MIN	MAX	UNITS	TEST CONDITIONS
I_R	Inverse Current		100 10	nA μ A	V_R = rated WIV V_R = rated WIV, T_A = 100°C
V_F	Forward Voltage		1.2	V	I_F = 200 mA
C	Capacitance		6.5	pF	V_R = 0, f = 1 MHz
Q_S	Stored Charge		12	nC	I_F = 10 mA, V_R = 10 V

NOTES:

1. These ratings are limiting values above which the serviceability of any individual semiconductor device may be impaired.
2. These are steady state limits. The factory should be consulted on applications involving pulsed or low duty-cycle operation.
3. For product family characteristic curves, refer to Chapter 4, D1.

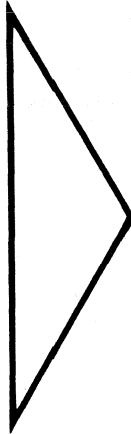
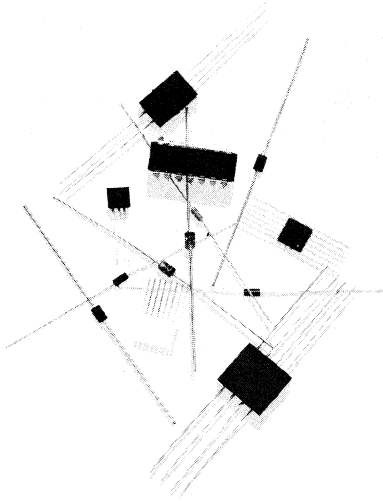

DEVICE SELECTION GUIDES 1

RELIABILITY 2

PRODUCT INFORMATION 3

FAMILY CURVES 4

GLOSSARY OF SYMBOLS AND TERMS 5

FAIRCHILD FIELD SALES OFFICES,
SALES REPRESENTATIVES AND
DISTRIBUTOR LOCATIONS 6

CURVE SET NUMBER D1

HIGH VOLTAGE SMALL SIGNAL DIODE

TYPICAL ELECTRICAL CHARACTERISTIC CURVES AT 25°C AMBIENT TEMPERATURE UNLESS OTHERWISE NOTED

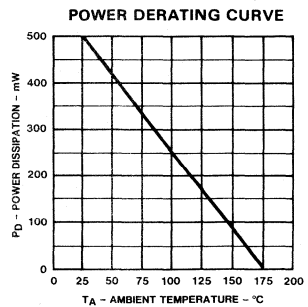
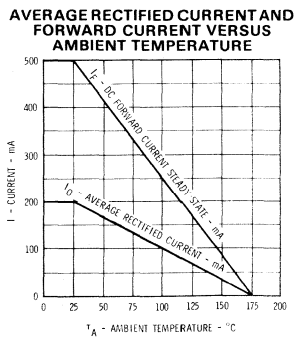
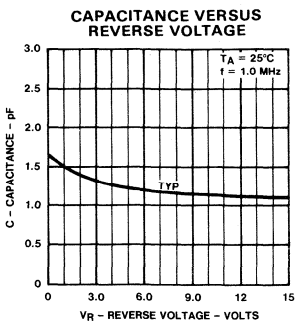
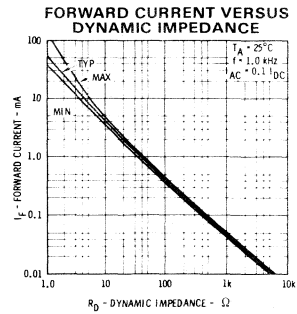
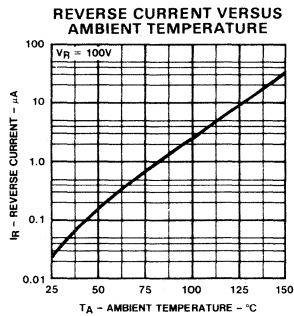
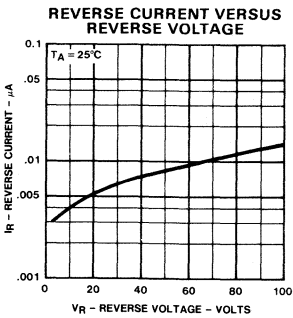
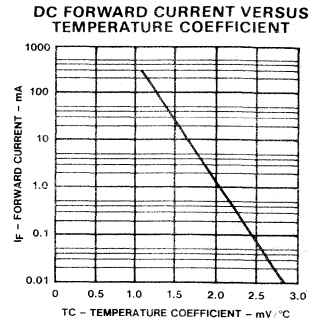
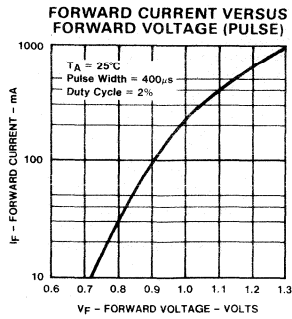
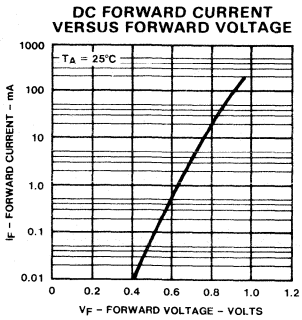

CURVE SET NUMBER D2

LOW LEAKAGE SMALL SIGNAL DIODE

TYPICAL ELECTRICAL CHARACTERISTIC CURVES

AT 25°C AMBIENT TEMPERATURE UNLESS OTHERWISE NOTED

FORWARD VOLTAGE VERSUS FORWARD CURRENT

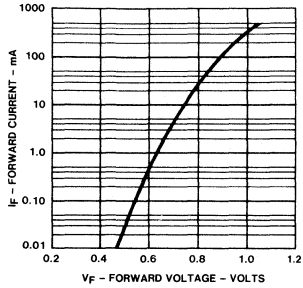

FORWARD CURRENT VERSUS TEMPERATURE COEFFICIENT

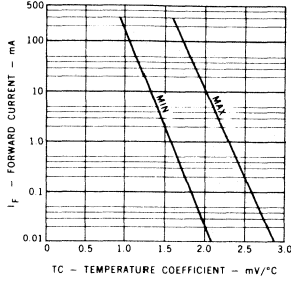

CAPACITANCE VERSUS REVERSE VOLTAGE

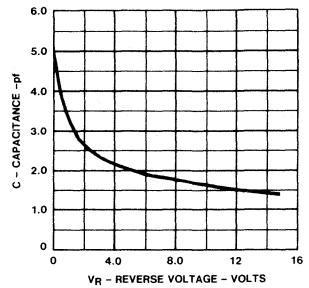

REVERSE VOLTAGE VERSUS REVERSE CURRENT

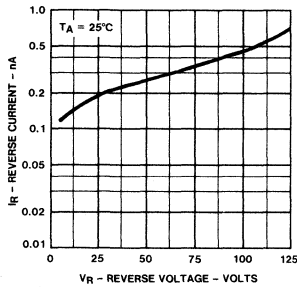

REVERSE CURRENT VERSUS AMBIENT TEMPERATURE

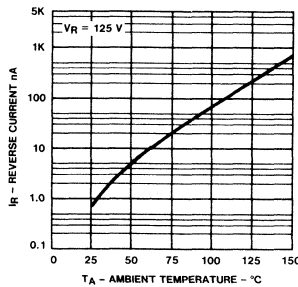

DYNAMIC IMPEDANCE VERSUS FORWARD CURRENT

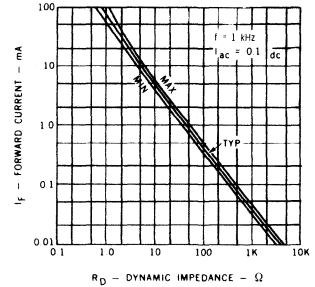

POWER DERATING CURVE

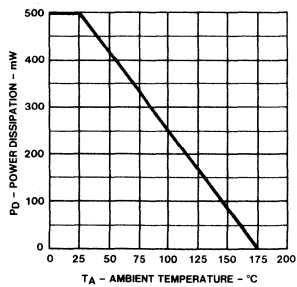

AVERAGE RECTIFIED CURRENT AND FORWARD CURRENT VERSUS AMBIENT TEMPERATURE

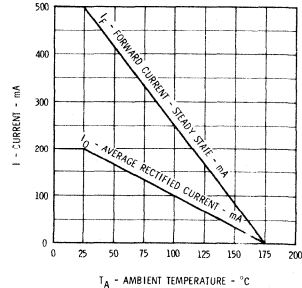

CURVE SET NUMBER D3

ULTRA-FAST SMALL SIGNAL DIODE

TYPICAL ELECTRICAL CHARACTERISTIC CURVES

AT 25°C AMBIENT TEMPERATURE UNLESS OTHERWISE NOTED

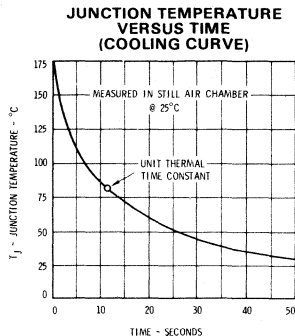
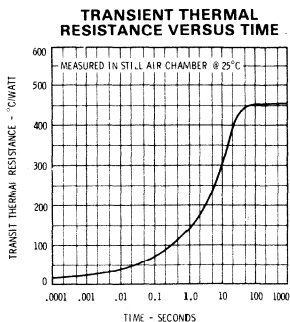
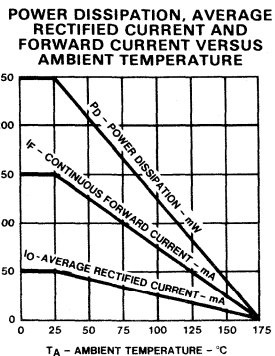
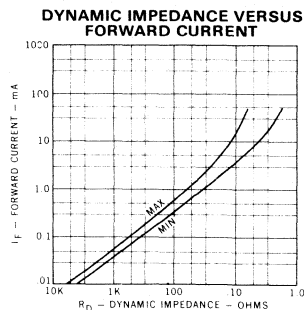
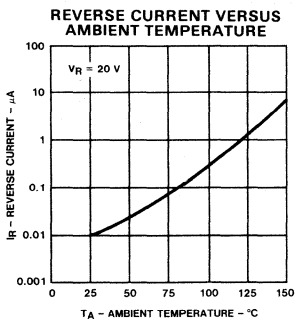
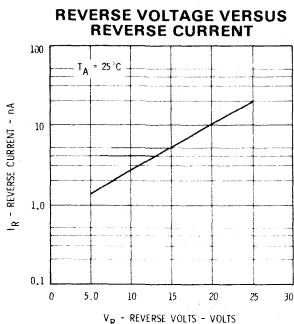
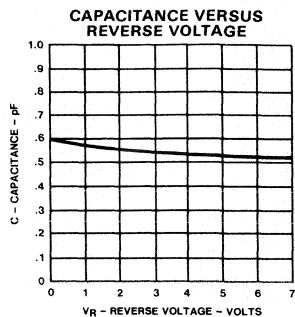
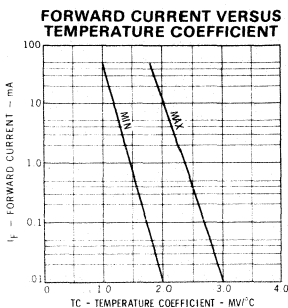
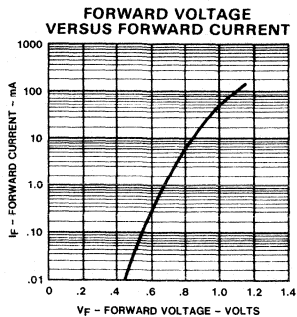

CURVE SET NUMBER D4

HIGH SPEED GENERAL PURPOSE SMALL SIGNAL DIODE

TYPICAL ELECTRICAL CHARACTERISTIC CURVES

AT 25°C AMBIENT TEMPERATURE UNLESS OTHERWISE NOTED

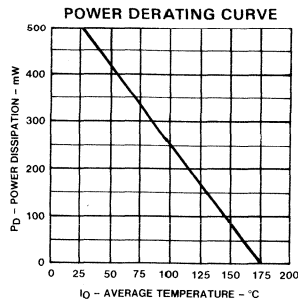
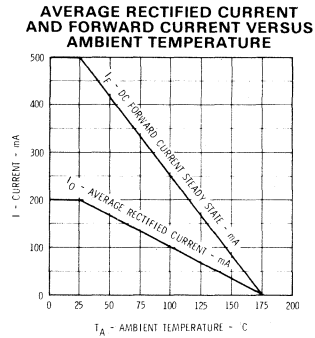
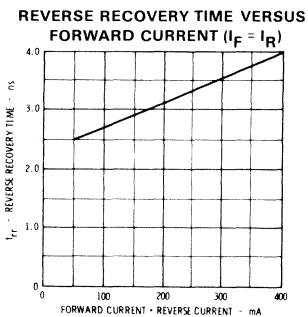
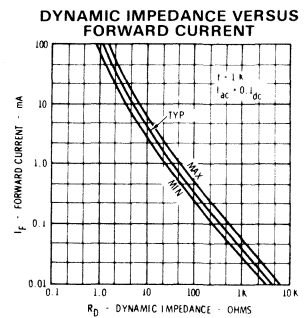
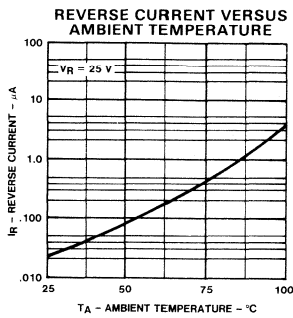
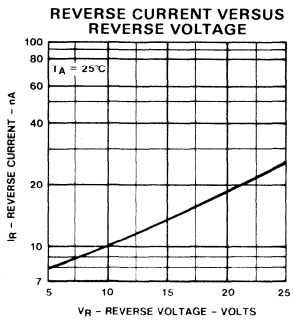
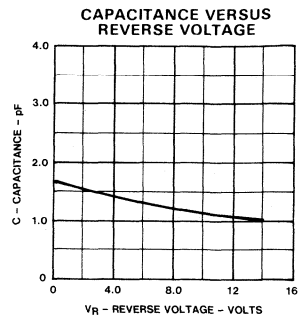
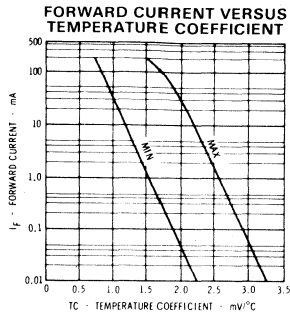
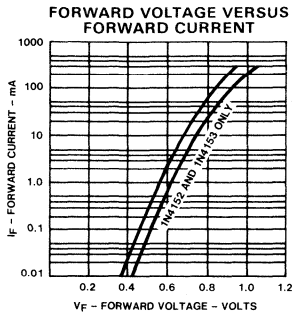

CURVE SET NUMBER D6
ULTRA-LOW LEAKAGE SMALL SIGNAL DIODE

TYPICAL ELECTRICAL CHARACTERISTIC CURVES
 AT 25°C AMBIENT TEMPERATURE UNLESS OTHERWISE NOTED

REVERSE CURRENT VERSUS REVERSE VOLTAGE

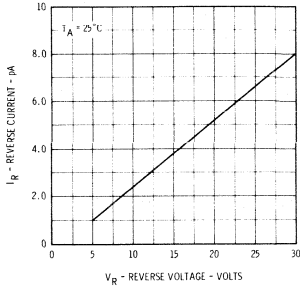

REVERSE CURRENT VERSUS TEMPERATURE

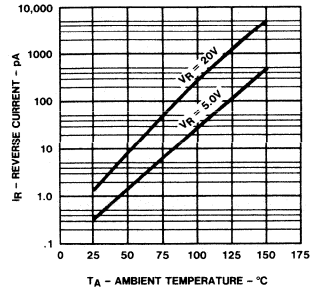

FORWARD VOLTAGE VERSUS FORWARD CURRENT

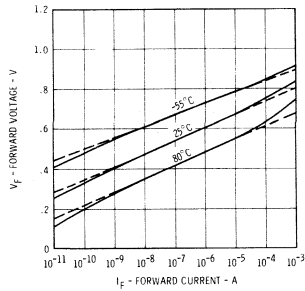

CAPACITANCE VERSUS REVERSE VOLTAGE

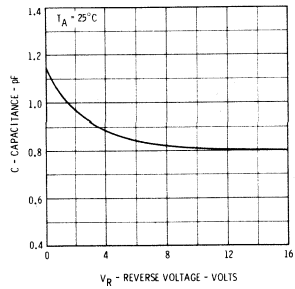

CURVE SET NUMBER D6

ULTRA-LOW LEAKAGE SMALL SIGNAL DIODE

A BOUND CIRCUIT FOR OPERATIONAL AMPLIFIERS

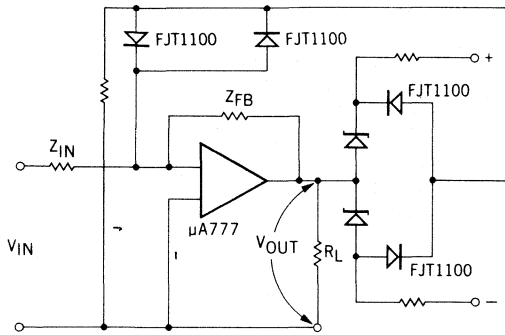

The bound circuit prevents overloading and saturation of operational amplifiers. The circuit has negligible effect on the operational amplifier until overload conditions occur. The use of the low leakage picoampere diode permits realization of extremely high input impedance for normal input voltages.

MOS FET PROTECTION CIRCUIT

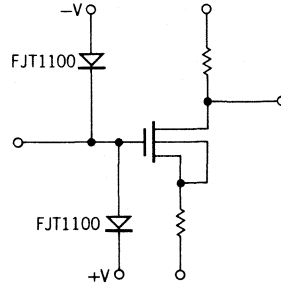

The picoampere diode affords excellent gate voltage protection while maintaining the DC input impedance at about one million megohms. In addition the very low capacity of the FJT1100 will have a relatively small effect on the circuit input capacity.

PEAK FOLLOWER CIRCUIT

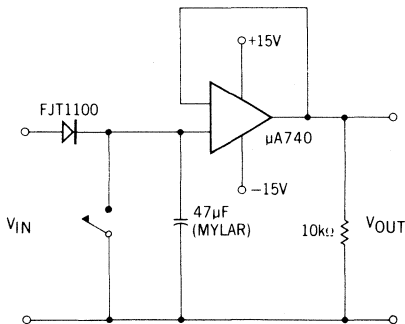

A nearly constant voltage peak follower circuit is available by using a picoampere diode. A comparison between the use of the FJT1100 and a "low leakage" FDH333 diode in the circuit is shown in the curves of V_{OUT} vs Time.

OUTPUT VOLTAGE OF THE PEAK FOLLOWER CIRCUIT VERSUS TIME

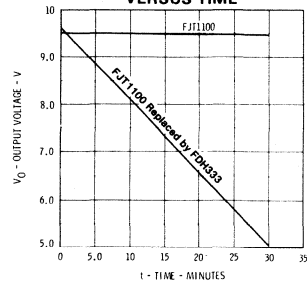

CURVE SET NUMBER D7

BANDSWITCH DIODE

TYPICAL ELECTRICAL CHARACTERISTICS AT 25°C AMBIENT TEMPERATURE UNLESS OTHERWISE NOTED

FORWARD CURRENT VERSUS FORWARD VOLTAGE

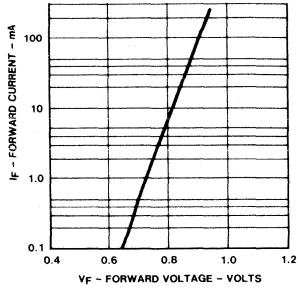

REVERSE CURRENT VERSUS AMBIENT TEMPERATURE

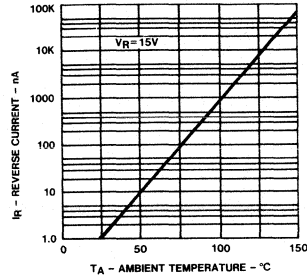

CAPACITANCE VERSUS REVERSE VOLTAGE

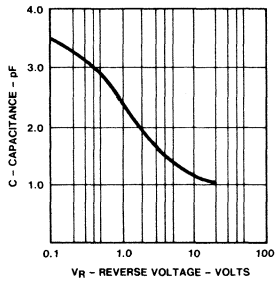

SERIES RESISTANCE VERSUS FORWARD CURRENT

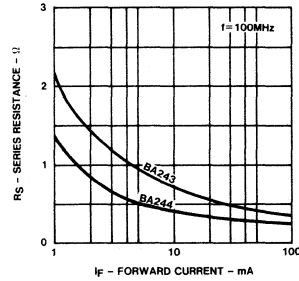

CURVE SET NUMBER D8
ABRUPT JUNCTION VARACTOR

TYPICAL ELECTRICAL CHARACTERISTIC CURVES
 AT 25°C AMBIENT TEMPERATURE UNLESS OTHERWISE NOTED

RF400

**FIGURE OF MERIT
 VERSUS FREQUENCY**

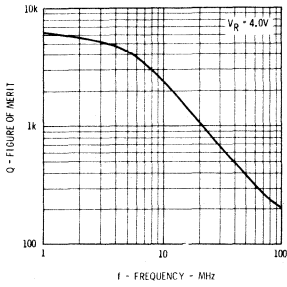

**FIGURE OF MERIT
 VERSUS REVERSE VOLTAGE**

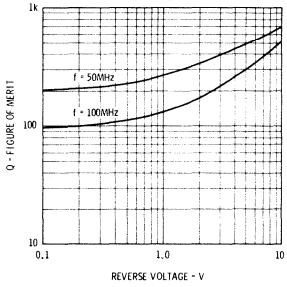

**CAPACITANCE VERSUS
 REVERSE VOLTAGE**

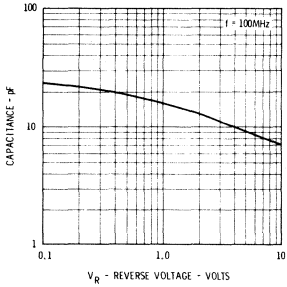

RF401

**FIGURE OF MERIT
 VERSUS FREQUENCY**

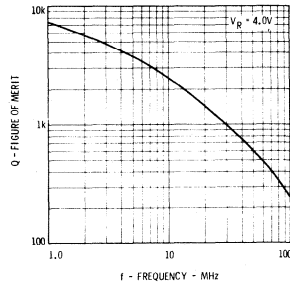

**FIGURE OF MERIT
 VERSUS REVERSE VOLTAGE**

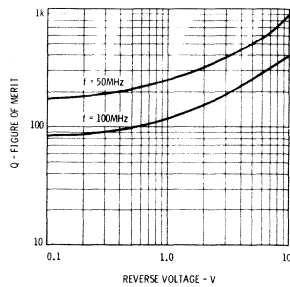

**CAPACITANCE VERSUS
 REVERSE VOLTAGE**

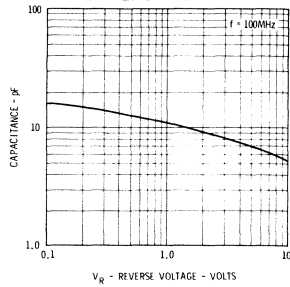

**RF400 AND RF401
 POWER DERATING CURVE**

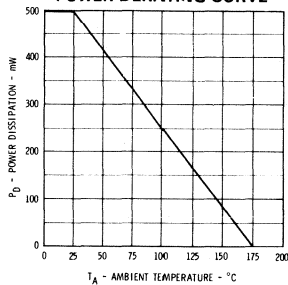

CURVE SET NUMBER D9

DUAL FM VARACTOR

TYPICAL ELECTRICAL CHARACTERISTICS AT 25°C AMBIENT TEMPERATURE UNLESS OTHERWISE NOTED

REVERSE CURRENT VERSUS REVERSE VOLTAGE

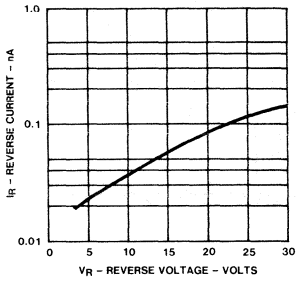

NORMALIZED CAPACITANCE VERSUS JUNCTION TEMPERATURE

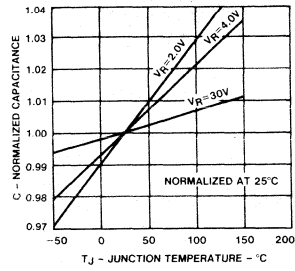

FIGURE OF MERIT VERSUS REVERSE VOLTAGE

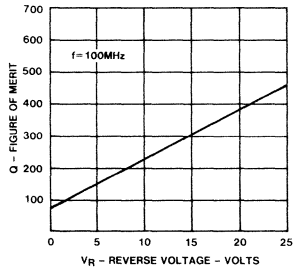
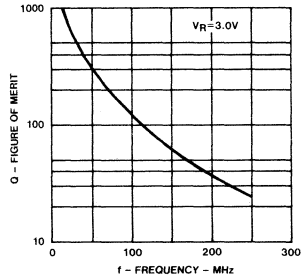

FIGURE OF MERIT VERSUS FREQUENCY



CURVE SET NUMBER D10

HOT CARRIER DIODE

TYPICAL ELECTRICAL CHARACTERISTIC CURVES AT 25°C AMBIENT TEMPERATURE UNLESS OTHERWISE NOTED

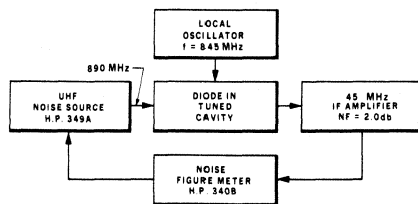
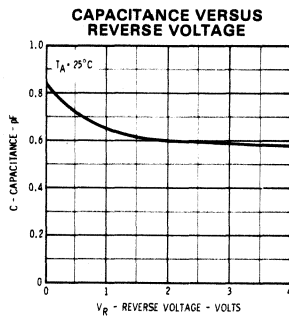
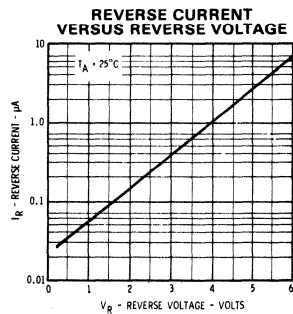
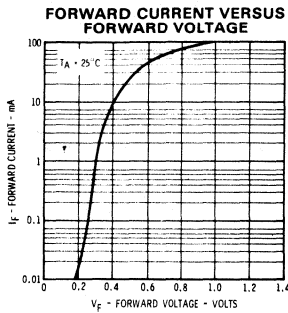

NOISE FIGURE TEST CIRCUIT

CURVE SET NUMBER D11
HYPER-ABRUPT JUNCTION UHF/VHF VARACTOR

TYPICAL ELECTRICAL CHARACTERISTICS
AT 25°C AMBIENT TEMPERATURE

**REVERSE CURRENT VERSUS
 REVERSE VOLTAGE**

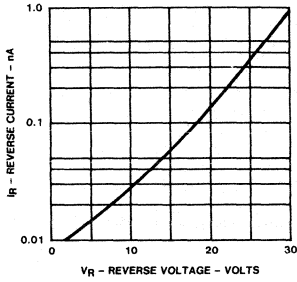

**CAPACITANCE TEMPERATURE COEFFICIENT
 VERSUS REVERSE VOLTAGE**

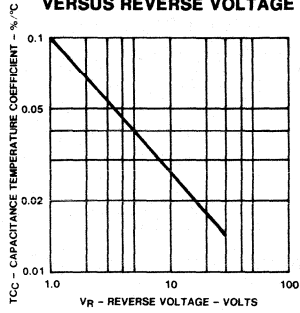

**CAPACITANCE VERSUS
 REVERSE VOLTAGE**

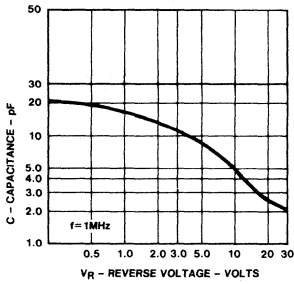

**FIGURE OF MERIT
 VERSUS FREQUENCY**

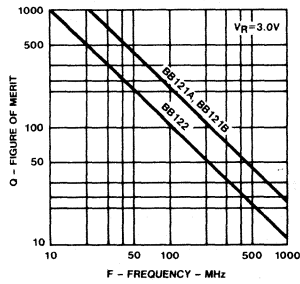

CURVE SET NUMBER D12
HYPER-ABRUPT JUNCTION VHF /FM VARACTOR

TYPICAL ELECTRICAL CHARACTERISTICS
AT 25°C AMBIENT TEMPERATURE

**REVERSE CURRENT VERSUS
 REVERSE VOLTAGE**

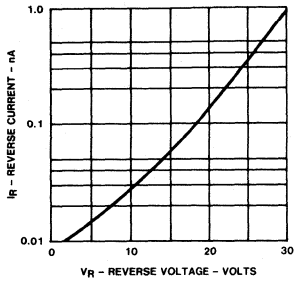

**CAPACITANCE TEMPERATURE COEFFICIENT
 VERSUS REVERSE VOLTAGE**

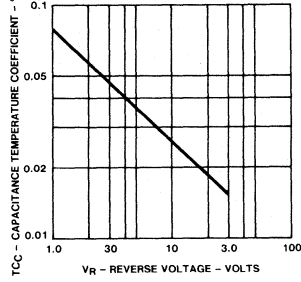

**CAPACITANCE VERSUS
 REVERSE VOLTAGE**

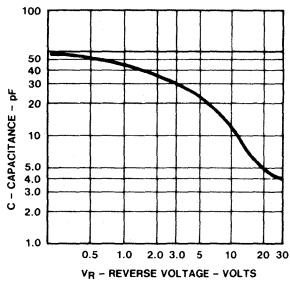

**FIGURE OF MERIT VERSUS
 FREQUENCY**

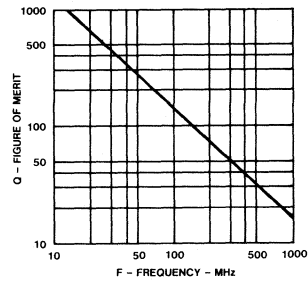

CURVE SET NUMBER D13

500 mW ZENER

TYPICAL ELECTRICAL CHARACTERISTICS AT 25°C AMBIENT TEMPERATURE

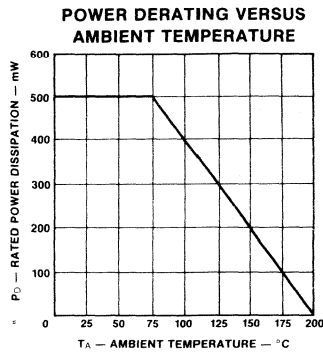
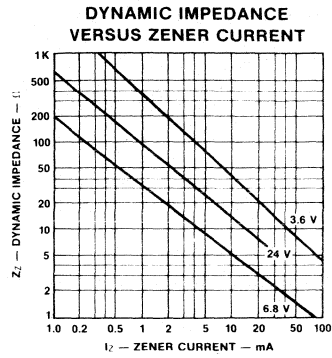
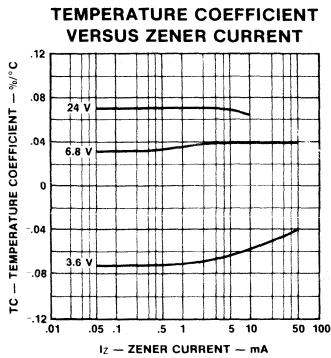

NOISE DENSITY MEASUREMENT CIRCUIT

1N4099 - 1N4121

1N4620 - 1N4627

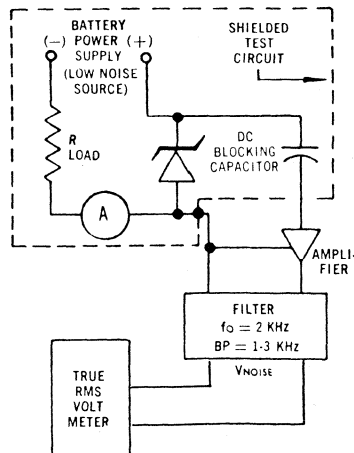

CURVE SET NUMBER D14

1 W ZENER

TYPICAL ELECTRICAL CHARACTERISTICS AT 25°C AMBIENT TEMPERATURE

TEMPERATURE COEFFICIENT VERSUS ZENER CURRENT

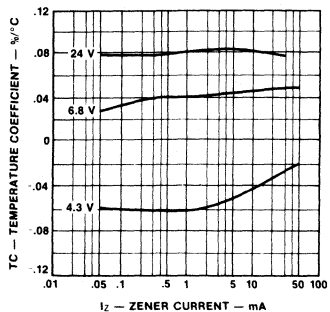

DYNAMIC IMPEDANCE VERSUS ZENER CURRENT

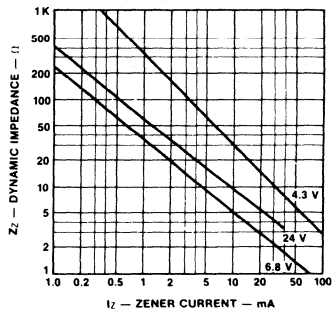

POWER DERATING VERSUS AMBIENT TEMPERATURE

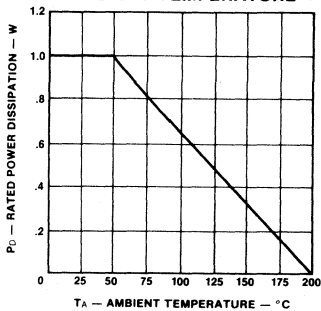

CURVE SET NUMBER D15
AIR-ISOLATED MONOLITHIC DIODE ARRAY

TYPICAL ELECTRICAL CHARACTERISTIC CURVES
 AT 25°C AMBIENT TEMPERATURE UNLESS OTHERWISE NOTED

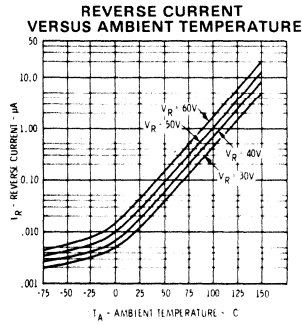
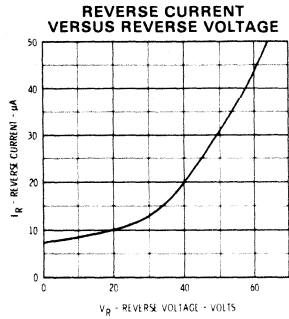
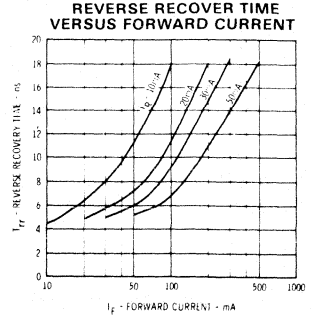
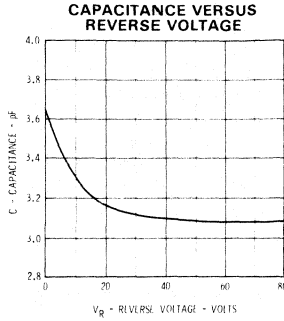
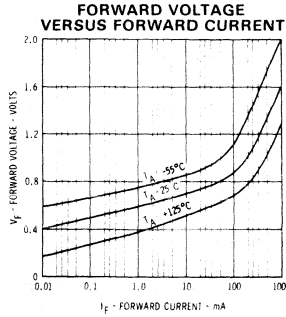

4

TEST CIRCUITS

To measure reverse current of an individual diode, the following test circuits are used:

COMMON CATHODE DIODES

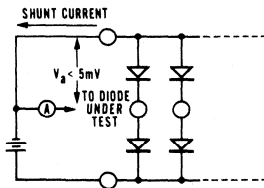

COMMON ANODE DIODES

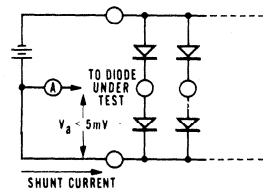

CURVE SET NUMBER D15

AIR-ISOLATED MONOLITHIC DIODE ARRAY

TEST CIRCUITS

Test requirement for V_{FM} and t_{fr} is as shown below; all leads should be as short as possible.

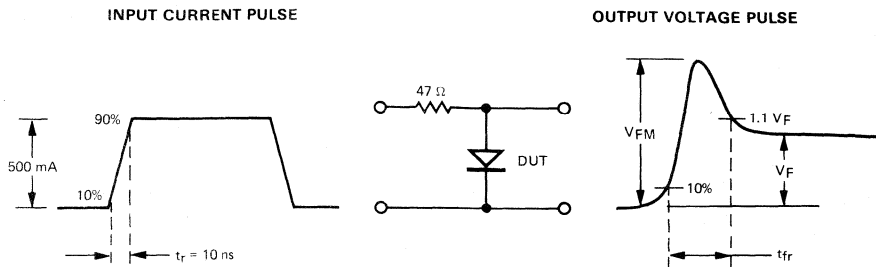

t_{rr} - REVERSE RECOVERY TIME TEST CIRCUIT

$I_f = I_r, I_{rr} = 0.1 I_r$

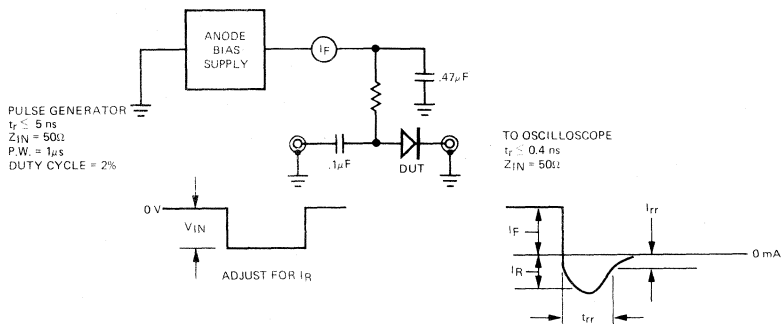

ΔV_F BRIDGE MATCHING CIRCUIT

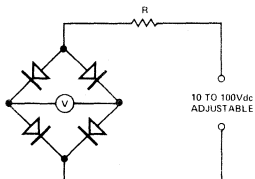

ΔI_R BRIDGE MATCHING CIRCUIT

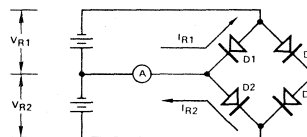

NOTES:

- R Varies depending on the current range. For the most often used current ranges, R is as follows:

Current Range (amperes)	R (ohms)
10^{-5} to 10^{-4}	10^6
10^{-4} to 10^{-3}	10^5
10^{-3} to 10^{-2}	10^4
or 10^{-n} to 10^{-n+1}	10^{n+1}

- V indicates mismatch of assembly.

NOTES:

- $V_{R2} = V_{R1} \pm 1\%$.
- $I_{R2} - I_{R1} = \Delta I_R$ (difference in I_R between diodes D1 & D2). To measure diodes D3 & D4, reverse cathode-anode terminal connections.
- A is a center reading pico ammeter. ΔI_R indicated directly on A.

CURVE SET NUMBER D16
GENERAL PURPOSE 1 A RECTIFIER

REVERSE RECOVERY TIME TEST CIRCUIT

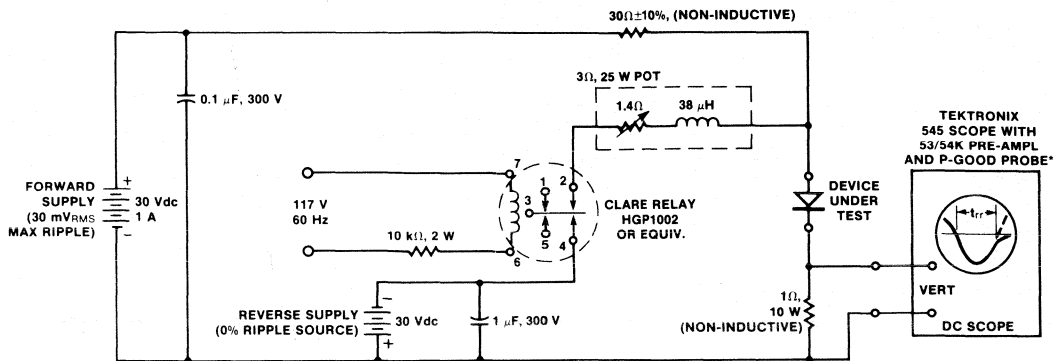

*OR EQUIVALENT

TYPICAL ELECTRICAL CHARACTERISTICS
 AT 25°C AMBIENT TEMPERATURE UNLESS OTHERWISE NOTED

TYPICAL RECOVERY PATTERN

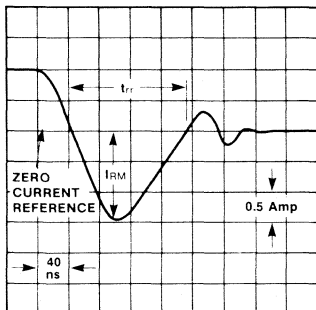

**INSTANTANEOUS FORWARD CURRENT
 VERSUS INSTANTANEOUS
 FORWARD VOLTAGE**

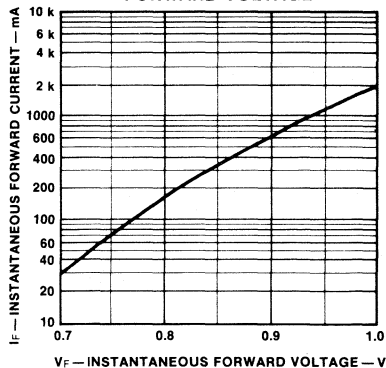

**RECTIFIED FORWARD CURRENT
 VERSUS TEMPERATURE**

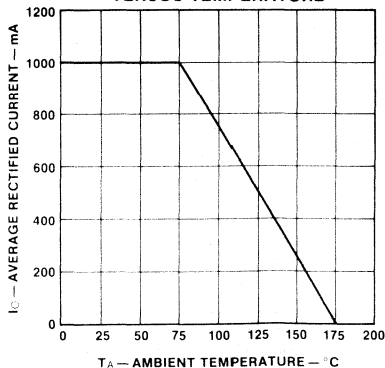

CURVE SET NUMBER D17
FAST RECOVERY 1 A RECTIFIER

REVERSE RECOVERY TIME TEST CIRCUIT

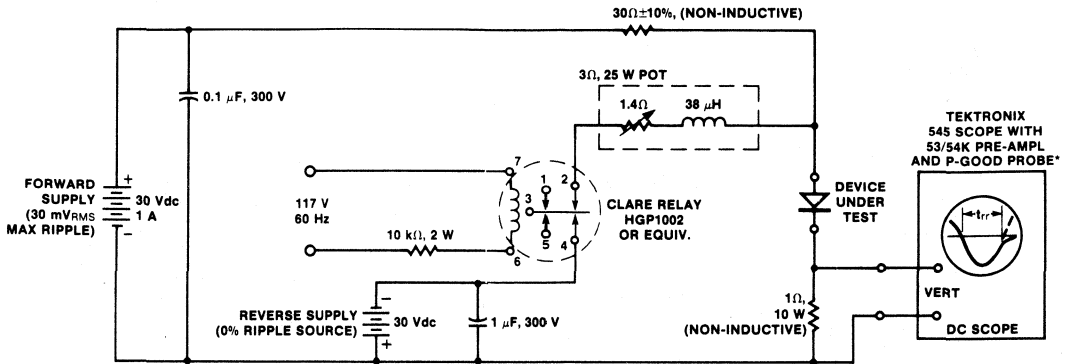

*OR EQUIVALENT

TYPICAL ELECTRICAL CHARACTERISTICS
 AT 25°C AMBIENT TEMPERATURE UNLESS OTHERWISE NOTED

TYPICAL RECOVERY PATTERN

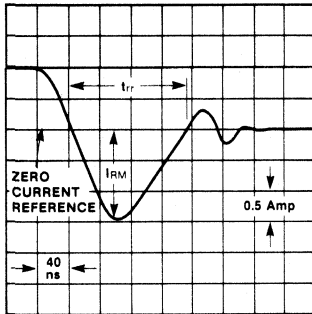

INSTANTANEOUS FORWARD CURRENT VERSUS INSTANTANEOUS FORWARD VOLTAGE

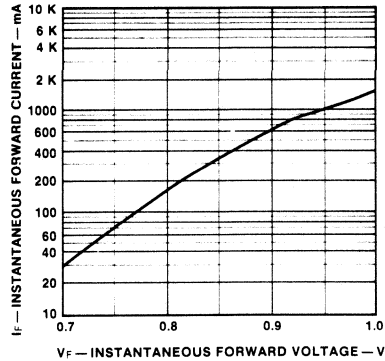

RECTIFIED FORWARD CURRENT VERSUS TEMPERATURE

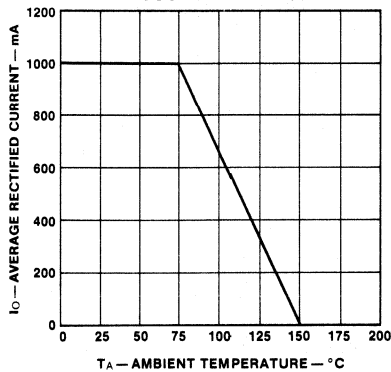

CURVE SET NUMBER D18

MATCHED DIODE ASSEMBLY

ΔV_F DIODE MATCHING CIRCUITS.

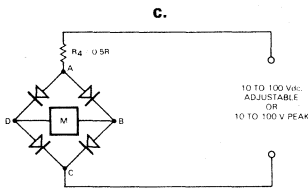
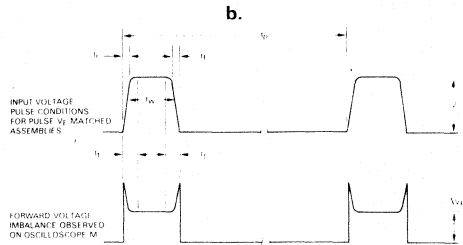
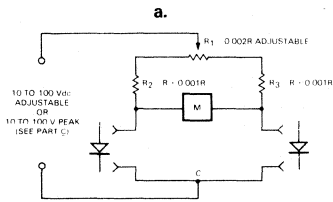

t_r	Pulse Rise Time (10 to 90% Amplitude)	= 1.0 μ s Max
t_f	Pulse Fall Time (90 to 10% Amplitude)	= 1.0 μ s Max
t_w	Pulse Width (50% Amplitude)	= 10 \pm 2.0 μ s
t_t	Transient Time	= 1.0 μ s Min
t_p	Period	= 1.0 ms
V	Voltage Input to Circuit "A or B"	= 10 to 100 V Adjustable
ΔV_F	Forward Voltage Difference Between Diodes (Measured Between Transient Times)	= As Specified

NOTES:

1. R varies depending on the current range. For the most often used current ranges, R is as follows:

Current Range (amperes)	R (ohms)
10^{-5} to 10^{-4}	10^6
10^{-4} to 10^{-3}	10^5
10^{-3} to 10^{-2}	10^4
or 10^{-n} to 10^{-n+1}	10^{n+1}

2. The input voltage pulse conditions shown above are employed at Fairchild in testing. The user may deviate from the specific conditions above with no variation in results providing the following general conditions are met:

- $\frac{t_w}{t_p} \leq 0.01$
- $t_w < 10$ ms
- Transients occurring during pulse rise and fall times are ignored in observing ΔV_F .

ΔI_R DIODE MATCHING CIRCUIT

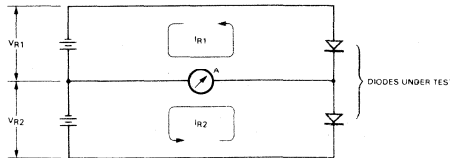

NOTES:

- $V_{R2} = -V_{R1} \pm 1\%$.
- $I_{R2} - I_{R1} = \Delta I_R$ (difference in I_R between two diodes under test).
- A is a center reading pico ammeter.

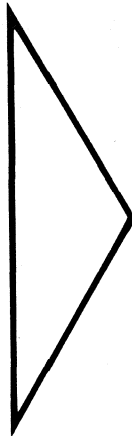
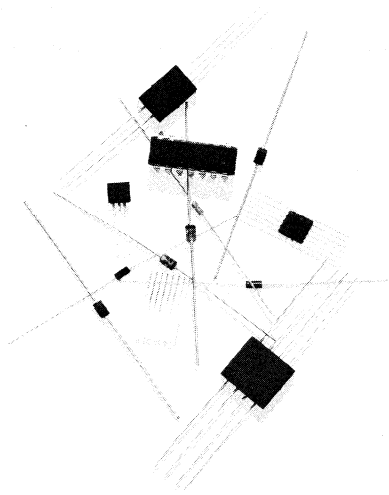

DEVICE SELECTION GUIDES	1
RELIABILITY	2
PRODUCT INFORMATION	3
FAMILY CURVES	4
GLOSSARY OF SYMBOLS AND TERMS	5
FAIRCHILD FIELD SALES OFFICES, SALES REPRESENTATIVES AND DISTRIBUTOR LOCATIONS	6

GLOSSARY OF SYMBOLS AND TERMS

BV Breakdown Voltage

Figure 1 shows the reverse characteristic of a typical silicon diode. Breakdown voltage is generally the reverse voltage at a point beyond the "knee" of the reverse characteristic. In Figure 1, the breakdown voltage is specified at a reverse current of I_{R2} .

C Capacitance

Diode capacitance is measured at a specified reverse voltage using an a.c. signal of specified frequency. When capacitance is measured at $V_R = 0$, this is sometimes denoted by the symbol C_0 .

C_c Case Capacitance

This is that part of a diode's total capacitance which is attributable to the diode package.

f₀ Series Resonant Frequency

The frequency of oscillation of the tuned circuit formed by the capacitance and inherent series inductance of the diode.

I_F Continuous Forward Current (Rating)

The maximum direct current that can be safely passed through a diode in the forward direction.

I_F Forward Current

The direct current passing through a diode in the forward direction.

I_F Forward Current

The forward current passing through a diode operated under switching conditions. See Figure 3.

I_F Peak Repetitive Forward Current

The maximum value of the peak point of a current that can safely be passed through a diode in the forward direction. This is a continuous (i.e. repetitive) rating.

I_{F(surge)} Peak Forward Surge Current

The maximum value of the peak point of a single cycle of current that can safely be passed through a diode in the forward direction. This is not a continuous rating.

I_{FSM} Peak Forward Surge Current

This rating is the same as $I_{F(surge)}$ but is more generally applied to rectifiers.

I_O Average Rectified Current

The average value of the forward current passing through a diode; as a rating, the maximum value of such current that can safely be passed.

I_R Reverse Current

The leakage current which flows in the reverse direction through a diode when a reverse voltage is applied to the diode. Referring to Figure 1, I_R is usually measured at a specified reverse voltage at a point below the "knee" on the reverse characteristic.

I_r Reverse Current

The peak value of reverse current which occurs immediately after switch-off. The value of I_r is limited by the circuit, which determines that rate at which stored charge can be dissipated. See Figure 3.

I_{rr} Reverse Current

The steady value of reverse current at equilibrium after switch-off. See Figure 3.

I_{RAV} Average Reverse Current

The average reverse current which flows when an a.c. voltage is applied across a diode.

I_{RM} Reverse Recovery Current

The peak value of reverse current which flows immediately after switching applied voltage from the forward to the reverse direction. I_{RM} is the same as I_r , generally used for rectifiers.

I_{RX} Reverse Current

I_{RX} is the symbol used to denote the reverse current of a single diode in an array at a time when all other diodes in the array are passing forward current. It is a measure of cross-talk between diodes.

I_Z Zener Current

The reverse current which flows in a zener diode at a point beyond the knee in the reverse characteristic. See Figure 2.

I_{Z(surge)} Maximum Zener Surge Current

The maximum value of the peak point of a single cycle of current that can safely be passed through a zener diode in the reverse direction. This is not a continuous rating.

I_{ZM} Maximum Zener Current

The maximum value of direct current that can safely be passed through a zener diode in the reverse direction.

L_S Series Inductance

Series inductance that is inherent in the construction of a diode, normally measured between two specified points on the diode leads.

N_D Noise Density

A measurement of the noise generated within a zener diode, both due to zener breakdown and internal resistance. Noise density, measured in microvolts rms per square root cycle, can be used to calculate rms noise over any frequency range.

NF Noise Figure

This is a ratio used to measure the noise generated within a diode. The ratio used is total output noise compared to that part of output noise due to input noise. This ratio, when multiplied by $10\log_{10}$, is known as noise figure and is measured in decibels (dB)

GLOSSARY OF SYMBOLS AND TERMS

Q Figure of Merit

Generally used as a measure of the "quality" of varactor diodes, Q , the figure of merit, is defined as the ratio of energy stored to energy dissipated.

Q_S Stored Charge

The charge stored in a diode when passing current in the forward direction. Stored charge is usually measured by switching the diode off and measuring the area of the I versus t curve from switch-off to equilibrium. See Figure 3.

R_D Dynamic Resistance

Small signal resistance of a diode operating in the reverse direction determined by the small signal or a c values of reverse current and reverse voltage. This parameter is of particular importance in varactor diodes.

r_{diff} Differential Resistance

Small signal resistance of a diode operating in the forward direction, determined by the small signal or a c values of forward current and forward voltage.

RE Rectification Efficiency

The ratio of d c load voltage to peak r f input voltage to a detector.

R_S Series Resistance

Small signal resistance of a diode operating in the forward direction determined by the small signal or a c values of forward current and forward voltage. Same as r_{diff} .

TC Temperature Coefficient

A coefficient which determines the variation of various parameters (e.g. Capacitance, Zener voltage, forward voltage) with temperature. A subscript is often used to denote the parameter to which the temperature coefficient refers.

t_{fr} Forward Recovery Time

The time interval between the point at which a diode is turned on and the point at which the forward voltage comes to within 10% of its equilibrium level. See Figure 4.

t_{rr} Reverse Recovery Time

The time interval between the point at which a diode is turned off and the point at which the reverse current comes to within 10% of its equilibrium level. See Figure 3.

V_F Forward Voltage

The voltage applied across a diode in the forward direction (anode more positive than cathode).

V_{FAV} Average Forward Voltage

The average value of forward voltage when current is being passed through a diode in the forward direction.

V_{fr} Forward Recovery Voltage

The peak value of forward voltage reached immediately after switch-on. The value of V_{fr} is limited by the circuit in which the diode is operating.

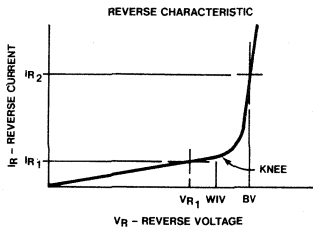

FIGURE 1

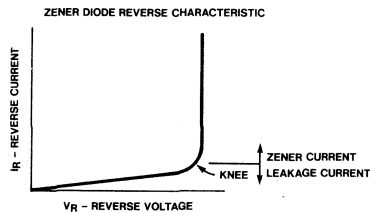

FIGURE 2

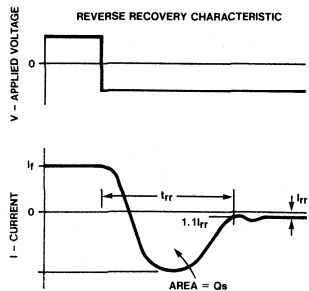

FIGURE 3

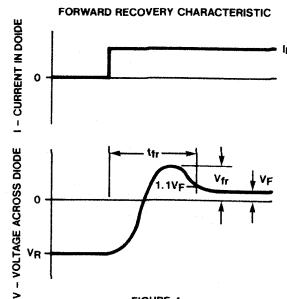

FIGURE 4

GLOSSARY OF SYMBOLS AND TERMS

V_{FX} Forward Voltage

V_{FX} is the symbol used to denote the forward voltage of a single diode in an array at a time when the condition of the other diodes in the array is defined. It can be used as a measure of cross-talk between diodes.

V_{PK} Peak Forward Voltage

The peak value of forward voltage reached immediately after switch-on. Same as V_{fr} .

V_R dc Blocking Voltage Rating

The continuous reverse voltage at which a rectifier can be safely operated without going beyond the "knee" in the reverse characteristic (Figure 1).

V_R Reverse Voltage

The voltage applied across a diode in the reverse direction (anode more negative than cathode).

V_{RRM} Peak Repetitive Reverse Voltage

The maximum value of the peak point of a reverse voltage that can be safely applied to a diode. This is a continuous (i.e. repetitive) rating and includes all repetitive transient voltages.

V_{Rrms} rms Reverse Voltage

The maximum rms value of a reverse voltage that can be safely applied to a diode.

V_{RRM} Working Peak Reverse Voltage

The maximum value of the peak point of a reverse voltage that can be safely applied to a diode. This is not a continuous rating and does not include transient voltages.

V_Z Zener Voltage

The reverse voltage across a zener diode at a point where zener current is flowing. See Figure 2.

W_{IV} Working Inverse Voltage

The maximum reverse voltage at which a diode can be operated below the "knee" on the reverse characteristic. See Figure 1.

Z_Z Zener Impedance

The small signal impedance of a zener diode operating in the zener region, determined by the small signal or a c values of zener current and zener voltage.

Z_{ZK} Zener Knee Impedance

Zener impedance measured at a defined point on the "knee" of the zener characteristic (See Figure 2).

ΔI_R Reverse Current Match

The difference in reverse current between any two diodes measured under the same condition for each.

ΔV_F Forward Voltage Match

The difference in forward voltage between any two diodes measured under the same conditions for each.

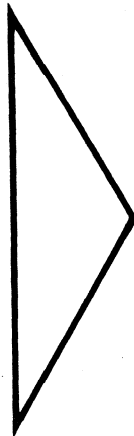
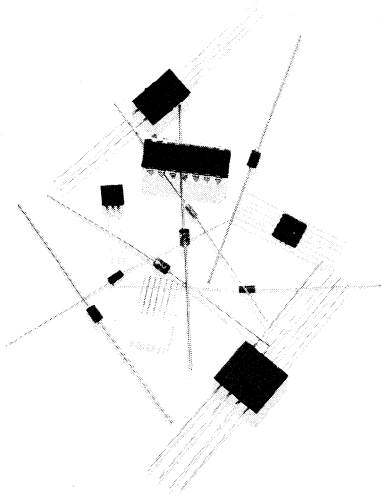

DEVICE SELECTION GUIDES	1
RELIABILITY	2
PRODUCT INFORMATION	3
FAMILY CURVES	4
GLOSSARY OF SYMBOLS AND TERMS	5
FAIRCHILD FIELD SALES OFFICES, SALES REPRESENTATIVES AND DISTRIBUTOR LOCATIONS	6

FAIRCHILD SEMICONDUCTOR

FIELD SALES OFFICE AND DISTRIBUTOR LOCATIONS

ITALY

SALES OFFICES

Fairchild Semiconduttori S.p.A.
Via Rosellini 12
20124 Milano
Tel: (02) 6 88 74 51
Telex: 36522

Fairchild Semiconduttori S.p.A.
Via Flaminia Vecchia, 653
00191 Roma
Tel: (06) 3 27 40 06 / 3 28 75 48
Telex: 63046

DISTRIBUTORS

Adelsy s.a.s.
Viale Lombardia 17/2
40141 Bologna
Tel: (051) 48 11 49 / 47 06 22
Telex: 51226

A.E.P.
Via Terracina 311
80125 Napoli
Tel: (081) 630 006

Claitron S.p.A.
Viale Certosa 269
20151 Milano
Tel: (02) 30 88 085/7

Compres s.r.l.
Viale Romagna, 1
20092 Cinisello Balsamo (MI)
Tel: 61 80 345 - 61 80 809
Telex: 39484

Gagliardi Elettronica s.n.c.
Via Vacchieri 8
10097 Regina Margherita (TO)
Tel: (011) 78 01 081/2/3
Telex: 22460

Hellis
Piazza Amendola 1
41049 Sassuolo
Tel: (059) 80 41 04

Microlem s.a.s.
Via Monteverdi 5
20131 Milano
Tel: (02) 22 03 17 / 22 03 26

Pantronic s.r.l.
Via Flaminia Nuova 219
00191 Roma
Tel: 32 48 66 / 32 88 048
Telex: 63405

FRANCE

SALES OFFICE

Fairchild Camera and Instrument (France) SA
121, Avenue d'Italie
75013 Paris
Tel: (1) 5 80 55 66
Telex: 260937 - 200614

DISTRIBUTORS

Almex SA
48, Rue de L'Aubepine
9160 Anthony Cedex
Tel: 666 21 12
Telex: 20067

Martec
36, Rue Louis Pasteur
92100 Boulogne

R.E.A.
9, Rue Ernest Cognacq
92300 Levallois
Tel: 758 11 11
Telex: 620630

Scientech
11, Avenue Ferdinand Buisson
75016 Paris
Tel.: 609 91 36
Telex: 26004

Societe Aufray and Cie
45, Rue Gustave Nicollet
76057 Le Havre Cedex
Tel: 16 35 21 34 00

Societe Aufray
Entrepots de la Asse Seine
Zone Industrielle
76800 Saint Etienne du Rouvray
Tel: 16 35 65 2 22

Feutrier
Avenue des Trois Glorieuses
42270 Saint Priest en Jarez
Tel: 15 77 74 67 33
Telex: 300021

Societe Gros S.
13, Avenue Victor Hugo
59350 Saint Andre les Lille
Tel: 16 20 51 21 33
Telex: 120257

Societe Gros S.A.
14, Avenue du General Leclerc
54000 Nancy
Tel: 15 28 24 22
Telex: 8507

S.C.T. (Societe Commerciale Toutelectric)
15-17, Boulevard Bon Repos
31008 Toulouse Cedex
Tel: 15 61 62 11 33
Telex: 531501

S.R.D. (Societe de Representation et de Distribution)
88, Rue du Commandant Mages
13001 Marseille
Tel: 15 91 50 33 55 / 64 23 78/79
Telex: 440076

DIMEX
12, Rue du Seminaire
94150 Rungis
Tel: 686 52 10
Telex: 200420

SPAIN

DISTRIBUTORS

Kontron, S.A.
División Electrónica
Costa Brava, 13
Mirasierra
Madrid - 34
Telf: 734 84 13
Telex: 23382 KONT E

Kimates Iberica, S.A.
Avda. Grimo. Franco 618, 5.º B
Barcelona-15
Telf: 230 02 04/230 02 05
Telex: 52927 ECROS E

REPRESENTATIVES

Fagor Electrotecnica, S. Coop.
San Andres s/n
s/n. Apartado 33
Mondragón (Guipúzcoa)
Tel: 79 12 44
Telex: 31621 FAGO E

GREECE

REPRESENTATIVE

Hellenic Scientific Representations Ltd
11 Vrassida Street,
Athens 612
Tel. 711.140 - 713.154
Tlx. 219330 GR

GERMANY**SALES OFFICES**

Fairchild Camera and Instrument (Deutschland) GmbH
Daimlerstr. 15
8046 Garching-Hochbrueck
W-Germany
Tel: (089) 32 00 31
Telex: 0524831 fair d

Fairchild Camera and Instrument (Deutschland) GmbH
3000 Hannover
Deitzenstrasse 15
Tel: (0511) 1 78 44
Telex: 09 22922

Fairchild Camera and Instrument (Deutschland) GmbH
8500 Nuernberg
Waldluststrasse 1
Tel: (0911) 40 70 05
Telex: 06 23665

DISTRIBUTORS

Elektronik 2000 Vertriebs GmbH
8000 Muenchen 80
Neumarkter Str. 75
Tel: (089) 43 40 61 - Telex: 0522561

Technoprojekt
Heinrich-Ebner-Str. 13
7000 Stuttgart
Tel: 56 17 12 - Telex: 07254490

Elcowa GmbH
6200 Wiesbaden-Schierstein
Zeilstrasse 32
Tel: (06121) 2 30 01
Telex: 04 186 202

Berger Elektronik GmbH
6000 Frankfurt
Am Tiergarten 14
Tel: (0611) 49 03 11
Telex: 04 12649

Unitronic GmbH
4000 Duesseldorf 30
Muensterstr. 338
Tel: (0211) 63 42 14
Telex: 08 586434

Spezial Electronic KG
Kreuzbreite 15
3062 Bueckeberg
Tel: (05722) 10 11
Telex: 0971624

IBH Ingenieurbüro Harm
Gutenbergring 35
2000 Norderstedt
Tel: (040) 52 31 933
Telex: 2174188

Dr. Dohrenberg
1000 Berlin 30
Bayreuther Str. 3
Tel: (030) 2 13 80 45 - Telex: 01 84860

BENELUX**SALES OFFICE**

Fairchild Camera and Instrument GmbH
Paradijslaan 39
Eindhoven - Holland
Tel: (040) 44 69 09 - Telex: 51024

DISTRIBUTORS

Rodelco Sa/Nv
Av. H. Hooverlaan, 32
B-1200 Brussel
Tel: (02) 73 54 137
Telex: 61415

Inelco Nederland BV
Joan Muyskenweg 22
NL-1006 Amsterdam
Tel: (020) 93 46 24
Telex 14622

SCANDINAVIA**SALES OFFICE**

Fairchild Semiconductor AB
Svartengsgatan 6
S-11620 Stockholm
Tel: (08) 44 92 55 - Telex: 17759

DISTRIBUTORS

E. Friis-Mikkelsen A/S
51 Krogshøjvej
DK-2880 Bagsvaerd
Tel: (02) 98 63 33 - Telex: 22350

Findip AB
Teollisuustie 7
P.O. Box 34
SF-02700 Kauniainen
Tel: (90) 50 22 55
Telex: 123129

Datamatik AS
Ostersjovelen 62
Oslo 6, Norway
Tel: (02) 26 63 30
Telex: 16067

Nordqvist & Berg
P.O. Box 9145
S-10272 Stockholm
Tel: (08) 69 04 00
Telex: 10407

ITT Multikomponent
Ankdammgatan 32
S-171 43 Solna Sweden
Tel: (08) 83 51 50
Telex: 10516

ITT Electronic Service Danmark
Fabriksparken 31
DK - 260 Glostrup - Denmark
Tel: (02) 45 22 45
Telex: 33355

Multikomponent
Kuortaneenkatu 1
SF-00510 Heleinki 51 Finland
Tel: 90-73 90 19/73 90 94
Telex: 121450

UNITED KINGDOM**SALES OFFICES**

Fairchild Camera and Instrument (England) Ltd.
Kingmaker House
Station Road
New Barnet, Herts. EN5 1NX
Tel: (01) 4 40 73 11
Telex: 262835

DISTRIBUTORS

Barlec Ltd.
219 London Road
East Grinstead, Sussex
Tel: (0342) 2 43 83

Comway Electronics Ltd.
John Scott House
Market Street
Bracknell, Berks. RG12 1JU
Tel: Bracknell (0344) 2 47 65 / 2 45 71
Telex: 847201

Gothic Electronics Ltd.
Beacon House
Hampton Street
Birmingham 19B9 31P
Tel: (021) 236 5060 / 236 8541
Telex: 338731

I.T.T. Electronics Services
Edinburgh Way
Harlow, Essex
Tel: Harlow (0279) 26 777
Telex: 81146

Macro Marketing Ltd.
396 Bath Road
Slough, Bucks.
Tel: Slough (0753) 3 54 44
Burnham (06286) 6 30 11
Telex: 847083

Salford Electrical Instruments Ltd.
Peel Works, Barton Lane
Eccles Manchester M30 8 HL
Tel: (061) 7 89 50 81
Telex: 667711

S.C. European Components Ltd.
Unit 9, M 40 Industrial Centre
Coronation Road
High Wycombe, Bucks.
Tel: (0494) 3 61 46 - Telex: 837163

Superdis Ltd.
41 Loverock Road
Reading RG3 1ED, Berks.
Tel: (0734) 59 49 33
Telex: 847147

Neilronics Ltd.
John F. Kennedy-Road,
Naas Road
Dublin 12, Ireland
Tel: (Dublin) 50 18 45
Telex: 4837

Most Electronics Ltd.
24 Broughton Street
Cheetham Hill
Manchester M88 NN
Tel: (061) 8317672
TWX: 66 83 04

AUSTRIA**AND EASTERN EUROPE****SALES OFFICE**

Fairchild Electronics
Schwedenplatz 2
A-1010 Wien
Tel: (0222) 63 58 21
Telex: 75096

DISTRIBUTORS

Electronic
Elektrot. Bauelem. Handelsges. GmbH
Ameisgasse 49-51
A-1140 Wien - Austria
Tel: (0222) 94 86 11
Telex: 12344

R.I.Z.

Bozidariceva 13
YU-41000 Zagreb
Tel: (041) 64 46 96 - Telex: 21288

OTHER DISTRIBUTORS.

W. Moor AG
Bahnstr. 58
CH-8105 Regensdorf
Tel: (01) 8 40 66 44 - Telex: 52042

Primotec AG
Wettingerstr. 23
CH-5400 Baden
Tel: (056) 26 52 62 - Telex: 58949

STG International Ltd.
Tel Aviv - Israel
Huberman Street 10 - P.O. Box 1275
Tel: (03) 24 82 31 - Telex: 32229

Teknim Ltd.
Tersanl Cad. Kut Han No. 38/805
Karahöy, Istanbul
Turkey
Tel: 44 40 33
Telex: 23540

Teknim Ltd.
Riza Sah Pehlevi Cad. 7
Kavaklidere, Ankara
Turkey
Tel: 27 58 00
Telex: 42155

Fairmont Electronic
P.O. Box 41102
Craighall 2024
South Africa
Tel: (48) 64 21 - Telex: 83227

FAIRCHILD

Fairchild reserves the right to make changes in the circuitry or specifications in this book at any time without notice.
Manufactured under one of the following U.S. Patents: 2981877, 3015048, 3064167, 3108359, 3117260; other patents pending.
Fairchild cannot assume responsibility for use of any circuitry described other than circuitry entirely embodied in a Fairchild product.
No other circuit patent licenses are implied.